

ALL SCIENCES ACADEMY



Proceeding Book of 4th International Artificial Intelligence and Data Science Congress ICADA 2024

March 14-15, 2024: Izmir, Turkey



PROCEEDING BOOK OF
4TH INTERNATIONAL
ARTIFICIAL
INTELLIGENCE AND
DATA SCIENCE
CONGRESS ICADA 2024

PROCEEDING BOOK OF 4TH ICADA 2024:

14 – 15 March 2024

Izmir, Turkey

Publication date: 20.03.2024

Publisher: All Sciences Academy

All Sciences Academy

<https://www.allsciencesacademy.com/>

4th International Artificial Intelligence and Data Science Congress ICADA 2024: edited by All Sciences Academy.

ISBN: 978-625-6530-91-1

As this is a serial book published annually, it has ISBN. ISBN links to a series of proceeding based on 4th International Artificial Intelligence and Data Science Congress ICADA 2024.

ISBN: 978-625-6530-91-1

International Conference Website

<https://as-proceeding.com/index.php/icada>

Publication of record for individual papers is online in the ASP Digital Library: as-proceeding.com. This website is used to distribute the articles into various databases. For citing online articles please use ISBN.

INTRODUCTION

We had the great honor of organizing the ICADA 2024. It was truly a great pleasure for us to greet a lot of participants from many different countries attending ICADA 2024! We firmly believe that the conference will become an important international event in the field of cross-industry discussion about innovations in Academic Studies.

ICADA 2024 was organized by All Science Academy located in Konya, Turkey.

Three cooperating organizations supported the four-day conference. There were 130 papers accepted for presentation at ICADA 2024, contributed from different countries. We had plenary speeches and several well-known scientists and experts, to give invited talks at different sessions.

The purpose of ICADA 2024 was to provide a forum for the participants to report and review innovative ideas, with up-to-date progress and developments, and discuss novel approaches to the application in the field of their own research areas and discuss challenges of doing science.

We sincerely hope that the exchange of ideas on doing research, science and improving education will help the participants, and international cooperation sharing the common interest will be enhanced.

On behalf the Organization Committee of ICADA 2024, we would like to heartily thank our cooperating organizations for all they have done for the conference. We would also like to thank the authors for their contribution to the proceedings; the participants and friends of ICADA 2024, for their interest and efforts in helping us to make the conference possible; and the Editorial boards for their effective work and valuable advice, especially the ICADA 2024 secretariat and the ICADA 2024 staff, for their tireless efforts and outstanding services in preparing the conference and publishing the Proceedings.

Publisher: All Sciences Academy

TABLE OF CONTENTS

Introduction	I
Table of Contents	II
Conference Chairs	VII
Scientific Committees	VIII
Document of Academic Incentive	IX
Document of International Conference	X

Table List of Content

Content of Full Papers

Page No	Title	Authors	Country	Submission ID
1-7	Optimal Power Flow Using a Genetic Algorithm Based on Optimization Control of its Parameters	Omar Sagban Taghi Al-butti, Mustafa BURUNKAYA	Turkey, Turkey	Mail Submission 1
8-14	Eğitimi Dönüştürmek: Yapay Zekânın Kişiselleştirilmiş Eğitim, Yönetmelik ve Kapsayıcılık Üzerindeki Etkisi	Çağla ODUNCULAR, Eylül KABAKÇI GÜNAY, Meltem İNCE YENİLMEZ	Turkey, Turkey, Turkey	Mail Submission 2
15-20	Design Optimization of Blade Antenna using Deep Learning Surrogates	Eysem Yılmaz, Mehmet Ali Belen	Turkey, Turkey	Mail Submission 3
21-25	Redesigning Introduction to Algorithm and Programming Course Under Conditions of Unanticipated Online Training: Empowered by GenAI	Mustafa Saratepeci, Hatice Yıldız Durak	Turkey, Turkey	Mail Submission 5
26-33	Implementing Predictive Models for Cash Flow Forecasting in Bank Branches: An Applied Study	Yudum Paçin, Bekir Said Moğul	Turkey, Turkey	Submission 5
34-37	ChatGPT: The Pandora's Box of Academic Integrity	Süleyman KASAP	Turkey	Submission 14
38-42	AI's Transformative Impact on Language Learning Methodologies	Süleyman KASAP	Turkey	Submission 15
43-48	Modeling of Model-Free Adaptive Perturbation-based Extremum Seeking Control as Computational Optimization Problem	Okkes Tolga Altinoz	Turkey	Submission 54
49-56	Tagging of Critical Medical Images Leveraging Clustering Approaches	Sezin Çağla Serfıceli, Berke Udunman and Emrah İnanl	Turkey, Turkey, Turkey	Submission 60
57-63	Veri Kaynağı Olarak Sohbet Robotları: Kamu Yönetimi Disiplininde Örnek Bir Araştırma	Ecem Buse Sevinç Çubuk	Turkey	Submission 61
64-75	Integral SMC with Disturbance Observer for Altitude Control of a UAV Quadcopter	Rabia Taseen, Inam Ul Hasan Shaikh and Ahsan Ali	Pakistan, Pakistan, Pakistan	Submission 70
76-82	Teknoloji Şirketlerinin Birleşme ve Satın Alma İşlemlerinin Makine Öğrenmesi Yöntemleri ile Tahmini	Eray YILMAZ, M. Hanefi CALP	Turkey, Turkey	Submission 73
83-98	Water Cycle Algorithm-based FOPID Controller for Tracking Control of Quadcopter	Farhan Ullah Khan, Ahsan Ali, Mansoor Ashraf, Inam Ul Hasan Shaikh	Pakistan, Pakistan, Pakistan, Pakistan	Submission 74
99-107	Comparative Analysis of LSTM, XGBoost, and Hybrid Approaches in Credit Card Fraud Detection	Ridwan Boya Marqas, TÜRKER TUNCER and FATİH ÖZYURT	Turkey, Turkey, Turkey	Submission 80
108-118	The organization and functioning of the civil service and public officials in Kosovo - Aspects of the analysis of the new legal basis	Ma. Blinera Veliu	Kosovo	Submission 21
119-134	Design a Robust PID-SMC Controller for Vibration Control of Vehicles	Ayesha Shabbir, Inam ul Hasan Shaikh, Ahsan Ali	Pakistan, Pakistan, Pakistan	Submission 82
135-144	Makine Öğrenmesi Yöntemleri ile Telekomünikasyon Sektörü için Müşteri Kayıp Tahmini	Ezgi GÜL, M. Hanefi CALP	Turkey, Turkey	Submission 89
145-151	Kolera Hastaları için Yapay Zeka Tabanlı Tahmin Modeli	M. Hanefi CALP	Turkey	Submission 117
152-155	Derin Öğrenme Tabanlı Hava Sıcaklığı Tahmini: Mumbai için Bir Vaka Çalışması	Anıl Utku	Turkey	Submission 121
156-163	Predicting Customer Satisfaction with Hybrid Basic Filter-Based Feature Selection Method	Tohid Yousefi, Özlem Varlıklar Aktaş	Turkey, Turkey	Submission 124
164-169	Is Climate Change a Hoax: Fake News Detection for Sustainability News	Serkan Özdemir	Turkey	Submission 125
170-177	Comparative Analysis of Machine Learning Models for Email Spam Detection	Abdulazeez Mousa, TÜRKER TUNCER, FATİH ÖZYURT	Iraq, Turkey, Turkey	Submission 133
178-184	Elektrik Dağıtım Şebekelerinde Blokzinciri ve Yapay Zekâ Teknolojileri ile Dijital Dönüşümün Sağlanması	Muhammet Yemen Boyacı, Doğan Çelik	Turkey, Turkey	Submission 144
185-193	Machine learning for seismic response prediction of structures	BENBOKHARI Abdellatif, BENAOUZ Chikh, MEBARKI Ahmed	Algeria, Algeria, Algeria	Submission 156
194-199	An Application of Sentiment Analysis in Recommender Systems	Leyla Yılmaz, Özlem Erdaş Çiçek	Turkey, Turkey	Submission 159
200-207	A Deep Learning-Based Approach for Image	Halit BAKIR, Ufuk	Turkey, Turkey,	Submission 162

	Denosing: Harnessing Autoencoders for Removing Gaussian and Salt-Pepper Noises	DEMİRCİOĞLU, Rezan BAKIR and Kemal ADEM	Turkey, Turkey	
208-216	Efficient Swin Transformer Model for Accurate Detection of Lung Cancer	Ishak Pacal	Turkey	Submission 167
217-223	Geri Dönüşüm Noktalarının Harita Üzerinde Mobil Cihazlar Kullanılarak Belirlenmesi	Ezgi Melda ERDOĞAN, Seda TUNCER ARSLAN	Turkey, Turkey	Submission 168
224-231	Using Prolog in education, to understand logical thinking and programming concepts, a use case in Albania	Anxhela Kosta, Endri Xhina, Ilma Lili	Albania, Albania, Albania	Submission 176
232-239	Heart Disease Classification Using Random Forest Machine Learning	Muhammet Çakmak	Turkey	Submission 178
240-250	Estimating Forced Convection Behavior of Magnetic Nanofluid in Wavy Tube Using Scaled Conjugated Gradient Algorithm and Feed-Forward Backprop Neural Network	Furkan Yıldırım, Mehmet Gürdal	Turkey, Turkey	Submission 179
251-255	An overview of using artificial neural networks to determine the behavior of steel beam-column connections	BOUBEKRI Amel, RAS Abdelouahab, BOUMECHRA Nadir	Algeria, Algeria, Algeria	Submission 181
256-261	Elektrokardiyogram İşaretlerin Öz kodlayıcı Yöntemiyle Sıkıştırılması	Yücel KOÇYİĞİT	Turkey	Submission 186
262-265	Artificial Intelligence and Its Use in Civil Engineering	Rachid RABEHI, Mohamed RABEHI, Mohammed OMRANE, Said ZAOUAI, Ahmed Rafik BELAKHDAR, Mohamed AMIEUR	Algeria, Algeria, Algeria, Algeria, Algeria	Submission 188
266-269	Akıllı Kent Uygulamaları Kapsamında Coğrafi Bilgi Sistemleri Çalışmalarının İncelenmesi	Mahmud Zahid MUTLU, M. Hanefi CALP	Turkey, Turkey	Submission 189
270-275	Exploring Large Language Models for clinical Named Entity Recognition – case of Albanian language	Elira Hoxha, Polina Çeço	Albania, Albania	Submission 194
276-282	YOLOv7 ve YOLOv8 Algoritmalarının Değerlendirilmesi: Savaş Uçaklarının Tespiti İçin Performans Analizi	Fatih Şengül, Kemal Adem	Turkey, Turkey	Submission 195
283-292	Machine Learning Models for Predicting and Reducing Vehicle Emissions to Improve Air Quality	Beytullah Eren and İdris Cesur	Turkey, Turkey	Submission 198
300-306	Utilizing Machine Learning for Accurate Estimation of Dam Reservoir Fluctuations	Elif Cesur, Merve Nur Durmuş, Güher Türkan	Turkey, Turkey, Turkey	Submission 220
307-314	Implementing Demand Forecasting with Machine Learning and Time Series Algorithms: A Case Study of a Weapon Manufacturer	Elif Cesur, Berra Can Şaylan, Zübeyde Dide Karaman	Turkey, Turkey, Turkey	Submission 223
315-318	Gıda Teknolojisinde Yapay Zeka Kullanımında Güncel Yaklaşımlar	Melikenur Türkol, Nazan Tokatlı Demirok, Seydi Yıkılmış	Turkey, Turkey, Turkey	Submission 225
319-322	Engelli Bireyler İçin Yapay Zeka Tabanlı Ulaşım Sistemlerinin Önündeki Engel Yaratan Faktörlerin Belirlenmesi	Ceyda AI, Ertuğrul Ayyıldız	Turkey, Turkey	Submission 228
323-331	Karaciğer Fibrozisi Evrelerinin Tahmininde Makine Öğrenimi Tabanlı Web Arayüzü	Hakan Yılmaz, Hatice Şevval Baki, Zeynep Nida Can, Tahsin Çökmez, Mehmet Özdem	Turkey, Turkey, Turkey, Turkey, Turkey	Submission 231
332-338	Environmental Footprint of Data Centers	Rafika HELAIMIA	Algeri, Algeria	Submission 172
339-345	Anomaly Detection Implementation with Digital Twin Approach Using Isolation Forest	Elif Cesur, Aleyna Yemekci	Turkey, Turkey	Submission 222

Content of Abstract Papers

Page No	Title	Authors	Country	Submission ID
1	The main roles of artificial intelligence in civil engineering	Chaima Mahkour, Djenette Mendjel and Souhila Rehab Bekkouche	Algeria, Algeria, Algeria	Submission 2
2	Data-Driven Approaches to Optimize Branch and Team-Based Targeting in Banking	Mert Güneş, Metin Samet Korkmaz	Turkey, Turkey	Submission 4
3	Ensuring Fairness in VAT: Leveraging Artificial Intelligence to Address Challenges in Harmonizing Tax Rates Across EU Member States	Simeana Beshi, Driola Susuri	Kosovo, Kosovo	Submission 7
4	Maximum Power Point Tracking in Photovoltaic Systems Using P&O and GWO Techniques: A Comparative Study	Mohammedi Imad Eddine, Korich Belkacem, Kouzou Abdellah and Elottri Ahmed	Algeria, Algeria, Algeria, Algeria	Submission 16
5	Maximizing English Language Proficiency with ChatGPT: A Comprehensive Exploration for Non-Native Speakers	DALI YOUCEF Lynda	Algeria	Submission 22
6	AI Applications in Environmental Engineering for Sustainable Solutions	BOUSLAH Mahmoud, MAZA Mekki, RAHMOUNI Zine EL Abidine	Algeria, Algeria, Algeria	Submission 26
7	Makine Öğrenmesi Kullanarak Öğrencilerin Özelliklerine Göre Matematik Dersindeki Başarı Durumunun Tahmin Edilmesi	Muhammet Semih KELEŞ, Ayşegül ALAYBEYOĞLU	Turkey, Turkey	Submission 28
8	Predicting Shear Wall Failure Modes: Advancements in Machine Learning for Enhanced Structural Safety	Nesreddine Djafar henni, Rachid Chebili	Algeria, Algeria	Submission 30
9	Machine Learning Advances in Predicting Shear Wall	Nesreddine Djafar henni, Rachid	Algeria, Algeria	Submission 33

	Failure Modes for Enhanced Structural Safety	Chebili		
10	Artificial Intelligence In Camel Racing : Health maintenance and prevention	DJEDDOU BENABID Amira, HOUSSOU Hind, DJEDDI Khaled and OUACHTATI Dounia	Algeria, Algeria, Algeria, Algeria	Submission 34
11	Vector-norm Regularized Multiple Kernel Fisher Null Learning for Novelty Detection	Shervin Rahimzadeh Arashloo	Turkey	Submission 36
12	Using Localized Information in Learning Multiple Kernels for Zero-Shot Detection of Face Presentation Attacks	Shervin Rahimzadeh Arashloo	Turkey	Submission 37
13	Perceptions of Teachers About AI In Teacher Education And Academic Practices	Irfan Bashir, Aiza Nisar, Afshan Naseem, Fariha Gul	Pakistan, Pakistan, Pakistan, Pakistan	Submission 39
14	An overview of using artificial neural networks to determine the behavior of steel beam-column connections	BOUBEKRI Amel, RAS Abdelouahab, BOUMECHRA Nadir	Algeria, Algeria, Algeria	Submission 52
15	University students' attitudes towards using artificial intelligence as a translation tool in academic writings	Neliada Memushaj	Albania	Submission 53
16	Innovative implemented MPC-MPPT for FPGA-Based boost converter	Habib BEY, Abdelouahad MAY, Fateh KRIM, Moncef KHITAS, Hamza FEROURA, Anis KRIM	Algeria, Algeria, Algeria, Algeria, Algeria, Algeria	Submission 55
17	An IC-MPPT Technique for Controlling the Boost Converter in Photovoltaic Systems Using Model Predictive Control	Abdelouahad MAY, Habib BEY, Fateh KRIM, Hamza FEROURA and Moncef KHITAS	Algeria, Algeria, Algeria, Algeria, Algeria, Algeria	Submission 56
18	"Smart villages" - a new concept in modern agribusiness	Katerina Kareska	North Macedonia	Submission 113
19	E-Ticaret Sektöründe Yapay Zeka Destekli Dinamik Ürün Fiyatlandırma Sistemi	Miraç ÖZTÜRK, Fehmi Ziya AKYÜZ, Resul ÖZEN, Mustafa KAMAŞAK	Turkey, Turkey, Turkey, Turkey	Submission 23
20	Optimal Res-UNET Architecture with Deep Supervision for Tumor Segmentation	Rehman Masood, Fazeel Abid, Salwa M. Akhtar, Fatima Nawaz and Abdul Ghafar	Pakistan, Pakistan, Pakistan, Pakistan, Pakistan	Submission 63
21	Perceptions of Communication and Public Relations Students in Romania on (AI) in University Education: An Online Survey Study	Sebastian Fitzek, Alina Bârgăoanu	Romania, Romania	Submission 64
22	A Comparative Study of CNN for R-T Based Faulty Line Insulator Using Deep Learning	Murk Shaikh, Qasim Ali Arain, Syed Akbar Ali Shah, Mehwish Shaikh, Mehak Fatima	Pakistan, Pakistan, Pakistan, Pakistan, Pakistan	Submission 65
23	Exploring the Dominant AI Approaches of 2024	Grella Ajvazi	North Macedonia	Submission 66
24	Makine Öğrenimi Yöntemleri İle Sağlık Analizi	Akın Çağatay Çalışkan, Ayşe Övgü Kınay	Turkey, Turkey	Submission 67
25	ÇEŞİTLİ ARAMA ALGORİTMALARININ BÜYÜK BOYUTLU LABİRENTLER İÇİN PERFORMANS İNCELEMESİ	Merve Menevşe, Ayşe Övgü Kınay	Turkey, Turkey	Submission 68
26	The Effect of Feature on Movie Recommendation Methods	Büşra Yağcı, Kadriye Filiz Balbal and Emel Kuruoğlu Kandemir	Turkey, Turkey, Turkey	Submission 72
27-28	Akıllı Evler için Yeni Nesil Yapay Zeka destekli Enerji Verimli IoT Uygulaması	Muhammet Ali Eroltu, Müge Erel-Özçevik	Turkey, Turkey	Submission 77
29	The Use of Artificial Intelligence in Instagram and Facebook: Opportunities and Perspectives	Ghulam Saïdar, Farhat Fatima	Pakistan, Pakistan	Submission 79
30	Addressing Missing Data in Surveys and Implementing Imputation Methods with SPSS	Robert Kosova, Adrian Naço, Shkelqim Hajrulla, Anna Maria Kosova	Albania, Albania, Albania, Albania	Submission 81
31	Pros and Cons of Artificial Intelligence in Education	Blerita Abazi Chaushi, Florije Ismaili and Agron Chaushi	North Macedonia, North Macedonia, North Macedonia	Submission 83
32	Earliest method of using surfactant-based cationic medium on a boron-doped diamond electrode with voltammetric Rifampin detection	Hemn A.H. Barzani	Iraq	Submission 85
33	Application of Artificial Intelligence and Response Surface Methodology (RSM) for predicting AC flashover voltages of contaminated composite insulators	Khaled Belhouchet, Abderrahim Zemmit, Lyamine Ouchen, Nadjim Altı, Assam Zorrig	Algeria, Algeria, Algeria, Algeria	Submission 86
34	Optimizing corona Ring Design of Polymeric Insulators for improved Electric Field by using FEM and a Grey Wolf Optimization Method	Khaled Belhouchet, Abderrahim Zemmit, Lyamine Ouchen, Nadjim Altı, Assam Zorrig	Algeria, Algeria, Algeria, Algeria	Submission 87
35	Recent Advances in Controller Area Network (CAN) Bus Technology of Autonomous Vehicle (AV)	Zeina Ali, Qutaiba I. Ali	Iraq, Iraq	Submission 88
36	Fuzzy controller for simulating a photovoltaic emulator	Samira Boumous, Zouhir Boumous, Sabrine Morakeb, Rayane Yasmine Mahfoudi	Algeria, Algeria, Algeria, Algeria	Submission 90
37	PSO optimization for MPPT control of photovoltaic panels	Zouhir Boumous, Samira Boumous, Med Mounir Abbes, Med Abderrezak Ghellouci	Algeria, Algeria, Algeria, Algeria	Submission 91
38	A Hybrid Quadratic Programming and Evolutionary Single-objective Optimization Algorithm: Empirical Study on CEC 2022 Benchmark Problems	Gülce Turhan, Ökkeş Tolga Altınöz	Turkey, Turkey	Submission 92
39	Optimizing PV-Powered Charging Infrastructure for Electric Vehicles: A Comparative Analysis of MPPT	TRAIBIZ Omar, OULAD BEN ZAROUALA Rachad	Morocco, Morocco	Submission 100

	Techniques			
40	Fault Diagnosis Approach Based on Improved Variational Mode Decomposition (IVMD) and Convolutional Neural Network (CNN)	Yahia Bouseloub	Algeria	Submission 103
41	Optimization of Continuous Soft Polyurethane Foam Production Considering Sustainability Parameters	Vivien Konyhas, Annamaria Polyákné Kovács	Hungary , Hungary	Submission 104
42	Advancing Waste Management: A Comprehensive Bibliographic Exploration of Artificial Intelligence Applications for Sustainability	Hamza Bellouk, Imane EL Mrabet, Mostafa Nawdali, Hicham Zaitan	Algeria, Algeria, Algeria, Algeria	Submission 105
43	Revolutionizing Wastewater Management: A Bibliographic Exploration of Artificial Intelligence's Role in Water Treatment	Hamza Bellouk, Imane EL Mrabet, Mostafa Nawdali, Hicham Zaitan	Algeria, Algeria, Algeria, Algeria	Submission 106
44	Fast Decryption Methods for The Somsuk-RSA Cryptosystem	Muhammad Asyraf Asbullah, Nur Adira Mohamad Azlan	Malaysia, Malaysia	Submission 112
45	Mid-Term Power Load Forecasting of a Statistically Modified Log-term Data by using the LSTM	Khalid Alhashemi, Okkes Tolga Altinoz	Turkey, Turkey	Submission 115
46	Modeling and optimization of pectin extraction from citrus peels using artificial neural networks (ANN) and response surface methodology (RSM)	Djerri Rofia, Himed Louiza, Berkani Mohamed , Trad khoja Esma Anissa, Barkat Malika	Algeria, Algeria, Algeria, Algeria, Algeria	Submission 120
47	Görüntü İşleme Teknikleri ve Yapay Zekâ Algoritmaları Kullanılarak Hurma Meyvesinin Sınıflandırılması	Abdullah Ammar KARCIOĞLU, Esra EFİTLİ	Turkey, Turkey	Submission 122
48	Güneş Enerjisi Santralleri İçin İyileştirilmiş Önleyici Bakım Planlaması	Halil Karayel, Ahmet Aktaş	Turkey, Turkey	Submission 126
49	OPTIMAL PLACEMENT AND SIZING OF DISTRIBUTED GENERATION IN RADIAL DISTRIBUTED NETWORK USING REPTILE SEARCH ALGORITHM	Qirat Nizamani, Ashfaque Ahmed Hashmani, Zohaib Hussain Leghari, Zeeshan Anjum Memon	Pakistan, Pakistan, Pakistan, Pakistan	Submission 129
50	Tf-Idf Vektör Modeli ve Yapay Zekâ Teknikleriyle Sahte Haber Tespiti	Abdullah Ammar KARCIOĞLU, Şuheda KARA, Melisa YALÇINKAYA	Turkey, Turkey, Turkey	Submission 130
51	Optimizing Crop Selection: Machine Learning Recommendations Based on Soil and Environmental Factors	AbdElKader Seif El Islem RAHMANI, Abdenour AIT AHMED, Mohamed Elhadi RAHMANI, Hadj Ahmed BOUARARA	Algeria, Algeria, Algeria, Algeria	Submission 131
52	Club Speed: Calculation of Golf Club Speed at the Time of Hit in the Golf Game Using Radar Signal and Images	Onur Koyuncu, Ali Erol, Ahmet Anil Dursun	Turkey, Turkey, Turkey	Submission 134
53	Deep Learning for Automated Grapevine Leaf Shape Classification: A Review of Methods and Applications for Cultivar Identification	Wahiba YAHIAOUI, Roumaissa BEKIRI and Ziane LAIADI	Algeria, Algeria, Algeria	Submission 135
54	Spacetime Dependent Scale Factor in FLRW Spacetime with Physical Significance	Mutahir Ali, Farhad Ali	Pakistan, Pakistan	Submission 136
55	Application of Bat algorithm and Taguchi design for Grading ring geometric dimensions optimization of 220 kV Polymeric Surge Arrester	Alti Nadjim, Belhouchet Khaled and Ouchen Lyamine	Algeria, Algeria, Algeria	Submission 137
56	A Generative AI Solution for Healthcare Problems : Application of Large Language Model	Hadj Ahmed Bouarara, Slimani Islem Abdelkader, Becharef Mohamed Amine	Algeria, Algeria, Algeria	Submission 138
57	A Proposed Method based on Machine Learning to Predict the Lattice Constant of Double-peroxide Materials	Inas Bouzateur, Sarah Guenou, Hedjar Hakima	Algeria, Algeria, Algeria	Submission 139
58	Use of artificial intelligence for estimating oil rates from producing wells in an Algerian oil field	Zakaria Adjou, Djamilia Boufades, Mustapha Miloudi	Algeria, Algeria, Algeria	Submission 148
59	Some Reasons to use Artificial Intelligence in Civil Engineering	Chalabi Youssouf, Aissaoui Soufyane, Mouaissa Mohamed Salah, Benali Khaled	Algeria, Algeria, Algeria, Algeria	Submission 149
60	ManagementAssist (MA): An AI-Powered Tool for Integrating AI into V-Cycle and Agile Methodologies	Nevzat DONUM, Huseyin KARACALI and Efecan CEBEL	Turkey, Turkey, Turkey	Submission 150
61	Artificial Intelligence-Driven Solution for Improving Automotive Software Development Processes	Nevzat DONUM, Huseyin KARACALI and Efecan CEBEL	Turkey, Turkey, Turkey	Submission 151
62	The Impact of Artificial Intelligence on EFL Vocabulary Learning	Mehmet ASLAN	Turkey	Submission 152
63	Modeling and Control of the Nonlinear Tubular Solid-Oxide Fuel Cell System Based on TS Fuzzy Theory and Predictive Control	Fayssal Ouagueni, Kada Boureguig, Abdelghafour Herizi and Riyadh Rouabhi	Algeria, Algeria, Algeria, Algeria	Submission 154
64	Gıda Tedarik Zincirinde İsafları Azaltmaya Yönelik Dijital Dönüşüm Süreçlerinin İncelenmesi	Leyla Kardelen Yıldırım, Emel Yontar	Turkey, Turkey	Submission 158
65	Gemini x ChatGPT: A discussion of two Chatbots about Artificial Intelligence in the Education	Norbert Annuš	Slovakia	Submission 161
66	The Revolutionary Impact of Artificial Intelligence in Healthcare and the Challenges in New Drug Design: The Case of Gliclazide	Hassina Fisli, Mohamed Lyamine Chelaghmia	Algeria, Algeria	Submission 163
67	Evaluation Of Medical Diagnosis Capabilities Of Three Artificial Intelligence Models – ChatGPT-3.5, Google Gemini, Microsoft Copilot	Yordanka Eneva, Bora Doğan	Bulgaria, Bulgaria	Submission 166

68	Comparative Analysis of AI-Supported and Manual JMeter Tests: The Role of Generative AI and LLM in Software Performance Testing	Burak TUZLUTAŞ, Murat ŞİMŞEK	Turkey, Turkey	Submission 169
69	Role of artificial intelligence in construction safety: A Comprehensive Review	Kabeer Aftab, Iqbal Khan and Qasim Hassan	Pakistan, Pakistan, Pakistan	Submission 170
70	AI-Powered Fecal Diagnosis: Empowering Poultry Farmers	BENMOHAMED Mohamed Said, MEKKAOUI Ahmed, BOUARARA Hadj Ahmed	Algeria, Algeria, Algeria	Submission 174
71	A Decision support for Construction Safety Risk Management Based on Artificial Intelligent	Ikram Nabila NEKKACHE, Fethi HAMZAoui, Nesrine EL HOUARI	Algeria, Algeria, Algeria	Submission 175
72	Evaluation of Text Summarization Technology: Potential for Improvement in Scientific Texts through the Pegasus Model	Ayşe Melek ÖZTÜRK, Cem ÖZKURT	Turkey, Turkey	Submission 180
73	Optimization of UPFC Device Parameters Using Artificial Intelligence Techniques	ELAGUAB Mohamed, Elbar Mohamed	Algeri, Algeria	Submission 182
74	Title Artificial intelligence and computational methods in drug discovery process: challenges, opportunities, and strategies	R. Ghemit, A. Makhloufi, M. El Kolli	Algeria, Algeria, Algeria	Submission 184
75	Strategic Integration of Artificial Intelligence for the Enhancement and Optimization of Daylighting in Architectural Structures	Alla Eddine KHELIL, Hathem KHELIL and Ahmed KAIHOUL	Italy, Italy, Algeria	Submission 191
76	Application of Deep Learning for Predicting the Financial Position of Pakistani Banking Sector	Asmatullah Zubair, Sania Bhatti, Areej Fatemah Maghji	Pakistan, Pakistan, Pakistan	Submission 197
77	Graphs Unveiled: Graph Neural Networks and Graph Generation	LÁSZLÓ KOVÁCS, ALI JLIDI	Hungary, Hungary	Submission 199
78	Automatic university course scheduling in two separate phases and with two hybridized methods: a real case study	Asmaa HOUAR and Talib Hicham BETAOUAF	Algeri, Algeria	Submission 200
79	Leveraging Hierarchical Timed Coloured Petri Nets and Machine Learning for Performance Evaluation Prediction in WSNs	Siham Zroug and Laid Kahloul	Algeri, Algeria	Submission 203
80	Image Authenticity Detection Based on the Local Features and Similarity Features	Mahin Malik, Aqsa Ijaz, Maryam Malik, Muhammad Awais	Pakistan, Pakistan, Pakistan, Pakistan	Submission 211
81	Automatic Verification of Arabophone Speaker by Hybrid Modelisation GMM-PSO	DJEMAI Mohamed, Elbar Mohamed	Algeri, Algeria	Submission 213
82	Modeling and Prediction using the Polynomial Regression Method of Electrical Quantities Found by Photovoltaic Modules under the Effect of Dust	Thameur OBEIDI, Mohamed ZITOUNI, Tahar BENAÏSSA, Tarek HAMMINE, Noureddine BENHABIB, Lakhdar BESSISSA, Mohamed HOURIER, Abdelbaki OBEIDI	Algeri, Algeria, Algeria, Algeria, Algeria, Algeria, Algeria, Algeria	Submission 216
83	Digital Twin Model for Elevator Anomaly Detection: A LOF Approach	Elif Cesur, Ayşe Balcı	Turkey, Turkey	Submission 221
84	Optimizing Heat Exchanger Efficiency: A Machine Learning Approach to Performance Modeling	Saidoune Fatma Zohra	Algeria	Submission 230
85	Climate Intelligent control in agricultural greenhouse	Ahmed Medjber, Mohamed Ridha Skender, Fethia Hamidia	Algeri, Algeria, Algeria	Submission 232
86	Asynchronous Machine Controlled by A Series Multi-Cells Converter Using FOPID Controller Tuning with ALO	Mohamed redha SKENDER, Ahmed MEDJBER, Fethia HAMIDIA, Amel ABBADI, Abdelhalim TLEMCANI	Algeri, Algeria, Algeria, Algeria, Algeria	Submission 208

COMMITTEE

ORGANIZING COMMITTEES

Honorary President

Prof. Dr. Saffet KÖSE

Congress President

Prof. Dr. Ayşegül ALAYBEYOĞLU

President of Organizing Committee

Assist. Prof. Dr. Fatma Günseli ÇIKLAÇANDIR

Prof. Dr. Adnan KAYA

Prof. Dr. Ayşegül ALAYBEYOĞLU

Prof. Dr. Merih PALANDÖKEN

Prof. Dr. Doğan AYDIN

Assoc. Prof. Dr. Aytuğ ONAN

Assoc. Prof. Dr. Levent AYDIN

Assist. Prof. Dr. Erdal ÖZBEK

Assist. Prof. Dr. Osman GÖKALP

Assist. Prof. Dr. Serpil YILMAZ

Assist. Prof. Dr. Emre ŞATIR

Assist. Prof. Dr. Mansur Alp TOÇOĞLU

Instructor Dr. Çağdaş EŞİYOK

Assist. Prof. Dr. Onan GÜREN

Assist. Prof. Dr. Ümit AYDOĞAN

Instructor Dr. Sümeyye SINIR

Instructor Dr. Ümit SARP

Instructor Dr. Tuğbanur ÖZEN BALABAN

Instructor Ayşegül NALBANTOĞLU

Scientific Secretariat

Instructor Dr. Sümeyye SINIR

SCIENTIFIC COMMITTEES

Prof. Dr. Abd Samad Hasan Basari, Universiti Tun Hussein Onn Malaysia
Prof. Dr. Ayşegül Alaybeyoğlu, İzmir Katip Çelebi University
Prof. Dr. Bilge Karaçalı, İzmir Institute of Technology
Prof. Dr. Bing Zhang, Sichuan University
Prof. Dr. Chirag Paunwala, Sarvajanic College of Engineering and Technology
Prof. Dr. Dunwei Gong, China University of Mining and Technology
Prof. Dr. Filiz Güneş, Yıldız Technical University
Prof. Dr. Müştak Erhan Yalçın, İstanbul Technical University
Prof. Dr. Narendra C. Chauhan, A D Patel Institute of Technology
Prof. Dr. Nejat Yumuşak, Sakarya University
Prof. Dr. Özlem Coşkun, Süleyman Demirel University
Prof. Dr. Saurabh Shah, GSFC University
Prof. Dr. Vedvyas Jayprakash Dwivedi, C. U. Shah University
Prof. Dr. Zahriladha Bin Zakaria, Universiti Teknikal Malaysia
Prof. Dr. Merih Palandöken, İzmir Katip Çelebi University
Assoc. Prof. Dr. Gökçe Nur Yılmaz, TED University
Assoc. Prof. Dr. Amit Thakkar, Charusat University
Assist. Prof. Dr. Ayşe Kalaycı ÖNAÇ, İzmir Katip Çelebi University
Assoc. Prof. Dr. Aytuğ Onan, İzmir Katip Çelebi University
Assoc. Prof. Dr. Cemal Haniççi, Bursa Technical University
Assoc. Prof. Dr. Cheng Jin, Beijing Institute of Technology
Assoc. Prof. Dr. Christos Volos, Aristotle University of Thessaloniki
Assoc. Prof. Dr. Gabriel Bekdaş, İstanbul University- Cerrahpaşa
Assoc. Prof. Dr. Hakan Özbaşaran, Eskişehir Osmangazi University
Assoc. Prof. Dr. Levent Aydın, İzmir Katip Çelebi University
Assoc. Prof. Dr. Mehmet Ali Belen, İskenderun Technical University
Assoc. Prof. Dr. Mohd Sanusi Azmi, Universiti Teknikal Malaysia Melaka
Assoc. Prof. Dr. Nour El Madhoun, Ecole d'ingénieurs informatique Paris-EPITA
Assoc. Prof. Dr. Peyman Mahouti, İstanbul University- Cerrahpaşa
Assoc. Prof. Dr. Sharnil Pandya, Symbiosis International University
Assoc. Prof. Dr. Sinan Melih Niğdeli, İstanbul University- Cerrahpaşa
Assoc. Prof. Dr. Trushit Upadhyaya, Charusat University
Assist. Prof. Dr. Amrithesh Kumar, National Institute Of Technology Silchar
Assist. Prof. Dr. Başak Esin Köktürk Güzel, İzmir Democracy University
Assist. Prof. Dr. Malaya Dutta Borah, National Institute Of Technology Silchar
Assist. Prof. Olgun Aydın, Gdansk University of Technology
Assist. Prof. Dr. Osman Gökalp, İzmir Katip Çelebi University
Assist. Prof. Dr. Partha Pakray, National Institute Of Technology Silchar
Assist. Prof. Dr. Serpil Yılmaz, İzmir Katip Çelebi University
Assist. Prof. Dr. Taimoor Khan, National Institute of Technology Silchar
Assist. Prof. Dr. Kadriye Filiz Balbal, Dokuz Eylül University, Department of Computer Science
Dr. Arpan Desai, Charusat University
Dr. Mohd Ibrahim Shapiai Razak, Malaysia-Japan International Institute of Technology, Universiti Teknologi Malaysia
Dr. Zihao Chen, Harbin Institute of Technology
Dr. Kashif Shah, Principal Applied Science Manager - Microsoft USA
Dr. Tracie Farrell, The Open University, Knowledge Media Institute (KMİ), UK
Dr. Ahmad Zareie, University of Sheffield, UK.
Dr. Sharafiz Abdul Rahim, University Putra Malaysia
Dr. Ahmet Aker, University Duisburg-Essen, Germany
Dr. Benjamin Kille, Norwegian University of Science and Technology

**4TH INTERNATIONAL ARTIFICIAL
INTELLIGENCE AND DATA SCIENCE
CONGRESS ICADA 2024
MARCH 14-15, 2024**

20.03.2024

14-15 Mart 2024 tarihlerinde MEET üzerinden çevrimiçi olarak gerçekleştirilen 4th International Artificial Intelligence and Data Science Congress ICADA 2024 konferansı akademik teşvik yönetmeliğinin 9. Maddesine istinaden “Tebliğlerin sunulduğu yurt içinde veya yurt dışındaki etkinliğin uluslararası olarak nitelendirilebilmesi için Türkiye dışında en az beş farklı ülkeden sözlü tebliğ sunan konuşmacının katılım sağlaması ve tebliğlerin yarıdan fazlasının Türkiye dışından katılımcılar tarafından sunulması esastır.” kriterlerini sağlamaktadır. Toplam 130 adet bildirinin yer aldığı kongre iki gün boyunca çevrimiçi olarak gerçekleştirilmiştir.

Türkiye dışından toplam 13 farklı ülkeden (**Fas, Cezayir, Slovakya, Kuzey Makedonya, Bulgaristan, Kosova, Pakistan, Arnavutluk, Romanya, İtalya, Macaristan, Irak**) katılım sağlanmış olup, 130 adet bildirinin 73 (%56,15) tanesi yabancı katılımcı tarafından sunulmuştur.

Kongremize ilginiz için teşekkür ederiz.

Saygılarımızla,



All Sciences Academy

**4TH INTERNATIONAL ARTIFICIAL
INTELLIGENCE AND DATA SCIENCE
CONGRESS ICADA 2024
MARCH 14-15, 2024**

20.03.2024

14-15 Mart 2024 tarihlerinde MEET üzerinden çevrimiçi olarak gerçekleştirilen 4th International Artificial Intelligence and Data Science Congress ICADA 2024 konferansı MART DÖNEMİ DOÇENTLİK BAŞVURU ŞARTLARI yönetmeliğinin 2. bölümde yer alan Uluslararası Bilimsel Toplantı tanımı “Farklı ülkelerden bilim insanlarının bilim kurulunda bulunduğu ve sunumların bilimsel ön incelemeden geçirilerek kabul edildiği toplantı.” şeklindedir.

4TH ICADA 2024 konferansı bilimsel komitesinin çoğunluğu yabancı bilim insanlarından oluşmaktadır. Aşağıdaki link ile bilimsel komite incelenebilir:

<https://as-proceeding.com/index.php/icada/committe>

Ayrıca konferansımızda hakem değerlendirmesi olup hakem değerlendirmesi olumlu sonuçlanmadan ücret talebinde bulunulmamaktadır.

2024 MART DÖNEMİ DOÇENTLİK BAŞVURU ŞARTLARI yönetmeliğinin 8. bölümde yer alan Bilimsel Toplantı tanımının b bendindeki “Diğer Uluslararası/Ulusal bilimsel toplantının düzenleme komitesinde, kurum/tüzel kişilik/karar organı tarafından resmi olarak görevlendirilmiş üniversite/enstitü/bilimsel kurum/branş derneği akademisyen temsilcisi bulunması zorunludur.” şeklindedir.

4TH ICADA 2024 konferansı düzenleme komitesinde farklı kurumlar tarafından görevlendirilmiş birden fazla üniversiteden akademik temsilciler bulunmaktadır. Aşağıdaki link ile düzenleme komitesindeki akademik temsilcilerin görevlendirme yazıları incelenebilir:

https://drive.google.com/file/d/1zDbV2I_ubMH6_bMzBDIV1vqZdtJS-bSb/view?usp=drive_link

Ayrıca görevlendirme yazıları ilgili konferansında özet ve tam metin kitapçıklarında yer almaktadır.

Kongremize ilginiz için teşekkür ederiz.

Saygılarımızla,



All Sciences Academy

14.09.2023

İlgili Makama

İzmir Katip Çelebi Üniversitesi Yapay Zeka ve Veri Bilimi Uygulama ve Araştırma Merkezi ile All Sciences Academy yayınevi ile beraber düzenlenmesi planlanan ICADA 2024 kongresi için ekteki listede yer alan akademik personelin organizasyon komitesinde yer alması uygun görülmüştür.

Gereğini rica ederim.

Yetkili kişi (Dekan, Enstitü Müdürü, Bölüm Başkanı)

Ad ve Soyad

İmza:

Prof.Dr. Gökçen BOMBAR

Tarih 14.09.2023

Prof. Dr. Adnan KAYA
Prof. Dr. Ayşegül ALAYBEYOĞLU
Prof. Dr. Doğan AYDIN
Prof. Dr. Merih PALANDÖKEN
Assoc. Prof. Dr. Aytuğ ONAN
Assoc. Prof.Dr. Levent AYDIN
Assoc. Prof. Dr. Esra Meltem KOÇ
Assist. Prof. Dr. Erdal ÖZBEK
Assist. Prof. Dr. Osman GÖKALP
Assist. Prof. Dr. Serpil YILMAZ
Assist. Prof. Dr. Emre ŞATIR
Assist. Prof. Dr. Fatma Günseli ÇIKLAÇANDIR
Assist. Prof. Dr. Mansur Alp TOÇOĞLU
Instructor Dr. Çağdaş EŞİYOK
Assist. Prof. Dr. Onan GÜREN
Assist. Prof. Dr. Ümit AYDOĞAN
Instructor Dr. Sümeyye SINIR
Instructor Dr. Tuğbanur ÖZEN BALABAN
Instructor Ayşegül NALBANTOĞLU



Optimal Power Flow Using a Genetic Algorithm Based on Optimization Control of its Parameters

Omar Sagban Taghi Al-butti^{*1}, Mustafa BURUNKAYA¹

¹Department of Electrical and Electronics Engineering / Faculty of Technology, Gazi University, Ankara, Türkiye

^{*}(osagban.al-butti@gazi.edu.tr) Email of the corresponding author

Abstract –One of the key factors that determine the sustainability and efficiency of the electrical power system is the optimum control of the variables of that system to reach the Optimal Power Flow (OPF), which takes into account security restrictions and both upper and lower limits of all components of the system, including power and voltage of generators, transformers and its tap changers, the capacity of transmission lines, shunt capacitors, and buses voltage. In this work, the genetic algorithm—one artificial intelligence technique—was employed for controlling the genetic algorithm's parameters to determine the optimum flow of power for the IEEE-30 bus standard test system, by controlling genetic algorithm (GA) parameters (mutation, and probability simple crossover), both of them affect the efficiency of the solution to this algorithm by widening the search space of those parameters rather than fixed values that do not reach the optimal value. Three different iterations (100, 500, and 1000) of the search space were tested to confirm the validity of the approach. One of the goals of the suggested strategy was to arrive at the lowest operating fuel cost possible. It is evident from the comparison of this outcome with the findings documented in the literature that the suggested method was successful and promising in addressing such problems.

Keywords – OPF, GA, AI, Cost, Control Variables

I. INTRODUCTION

Electrical energy has become one of the requirements of modern life and has entered into all fields. The electricity industry has become more expensive and complex due to the stages it goes through from production to distribution and the accompanying methods of supervision and control, which has led producers, companies, and countries, to reduce generation costs.

The problem of the optimal flow of power is considered one of the most important of these problems that researchers face to find the optimal fuel cost due to the complexity of power systems and safety restrictions that must be taken into account. The old and traditional methods were not able to deal flexibly in solving such problems, because they contain many non-linear variables. One of the methods that help to solve these problems is artificial intelligence by employing it in metaheuristic algorithms such as GA and others, which employ biological evolution, herds, and swarms in nature, in addition to the laws of electrical physics [1]. The biological evolution process acts as the inspiration for the genetic algorithm, which is one of the most effective approaches to addressing optimal power flow problems. Its efficiency and accuracy have been demonstrated. The GA to solve the OPF issue was used in [2], the adapted GA by adjusting the size of the population was used in [3], the improved GA was used in [4], the enhanced GA was used in [5], and in [6] a comparison was made between the PSO and GA in, the combined GA was used in [7], a comparison was made between the GA, PSO, and EP in [8]. The GA method was used in [9] for enhanced system security.

In this study, a different method is adopted for resolving the OPF issue by controlling the affected parameters of GA (mutation, and the probability of simple crossover) to reach the optimal fuel cost.

II. MATERIALS AND METHOD

The optimum adjustment of control variables, like the active power and voltage of generators, transformer tap changer, phase angles, and transmission line ampacity, while reducing a function of objective, like the cost of generation fuel [9], is the fundament formulation of the problem of the OPF, this goes like follow:

A. Objective Function

This task aims to minimize fuel costs and can be expressed according to the equation below.

$$F_T = \sum_i (c_i P_{Gi}^2 + b_i P_{Gi} + a_i) \quad (1)$$

Here c_i , b_i , and a_i are the coefficients of cost for i th generator.

B. Restrictions of the Problem

The OPF problem lies in adhering to the system's limits and needs to be solved within them[10], [11]. The mathematical formula for these constraints, which are the upper and lower boundaries for the generation of active and reactive power, voltage values, and apparent power flows in the buses, is given by the following equations. These restrictions are divided into equality and inequality restrictions.

Equality restrictions of power load flow:

$$P_i = \sum_{j=1}^N V_i |V_j| |Y_{ij}| \cos(\delta_i - \delta_j - \theta_i) \quad (2)$$

$$Q_i = \sum_{j=1}^N V_i |V_j| |Y_{ij}| \sin(\delta_i - \delta_j - \theta_i) \quad (3)$$

Inequality restrictions of variable:

$$P_G^{min} < P_G < P_G^{max} \quad (4)$$

$$Q_G^{min} < Q_G < Q_G^{max} \quad (5)$$

$$V_i^{min} < V_i < V_i^{max} \quad (6)$$

$$S_{ij}^{min} < S_{ij} < S_{ij}^{max} \quad (7)$$

The boundaries, both lower and higher of the control variables are represented as follows, where S_{ij} is the line capacitance between the buses, Y_{ij} is the admittance of the line, δ is the angle of voltage, θ_i is the phase angle, and P_i and Q_i are the active and reactive power of the i th generator.

C. Proposed Method of Solution

Extending the search space for the parameters (crossover and mutation) that influence the genetic algorithm's effectiveness is the suggested solution. The range of search for both the probability of mutation and simple crossover is typically between (0.001,0.01), and (0,1) respectively, the value of repetitions (100, 500, 1000) that will be searched within these ranges. The advantage of this method is that it allows us to find the optimal solution rather than methods that use fixed values for choosing these parameters. However, one drawback of this suggested method is that expanding the search space will increase the computational time. The OPF problem is solved in this study using GA to identify the

optimal solution that meets the constraints of equality and inequality as well as system operation requirements. The suggested method's algorithm is listed below.

- Initialize the GA parameters (crossing-cover ratio, population size, number of generations, and mutation rate).
- While adhering to equality and inequality restrictions and system operation requirements, the initial set of GAs (bus voltage, generator active power, transformer tap changer settings, and shunt capacitors compensation) for each parameter is selected at random.
- Find all the variables and determine the power flow using the Newton-Raphson method.
- Assess each agent's fitness.
- Use the roulette wheel method to determine the paternity of two chromosomes to reproduce.
- Use the crossover operator.
- The mutation parameter is applied.
- Continue doing the previous steps until the halting requirement is met.
- The optimal value is produced by the chromosome that has the best.

Table 1, shows the parameters for the conventional and proposed GA.

Table 1. Parameters of GA

Item	Conventional GA	Proposed GA
Max.generation	20	20
Pop. size	20	20
Mutation	0.01	Range [0.001-0.01]
Crossover	0.8	Range [0-1]

III. RESULTS

The IEEE 30 standard bus testing system was used in the study and all bus and line data and information are reported in [12] and also available at (www.ee.washington.edu/research/pstca/). The model applied to the study consisted of 41 branches, 9 VAR compensators, 4 transformers, and 6 generators whose locations are fixed as shown in Fig 1. The cost coefficients for generation fuel and control variables for active power are according to Table 2.

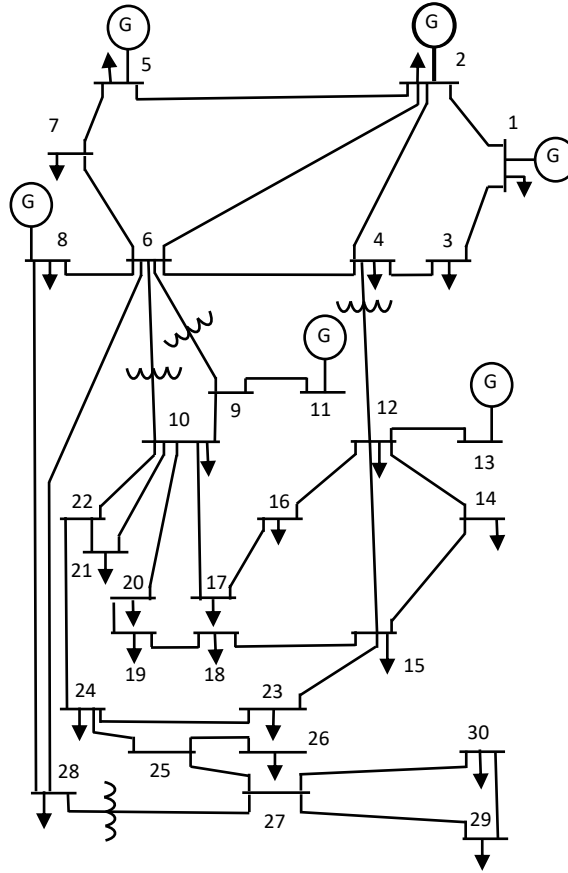

Fig. 1 IEEE 30-bus standard test system

Table 2. Fuel cost factors and real generating power limits

Bus No.	P_G min	P_G max	Cost Function
1	50	200	$2P_i+0.00375P_i^2$
2	20	80	$1.75P_i+0.01750P_i^2$
5	15	50	$1.0P_i+0.0625P_i^2$
8	10	35	$3.25P_i+0.00834P_i^2$
11	10	30	$3.0P_i+0.025P_i^2$
13	12	40	$3.0P_i+0.025P_i^2$

The results of using the suggested method and contrasting it with the conventional GA are summarized in Table 3, where the maximum and minimum bounds of the control variables that need to be considered are shown in the first and second columns. The cost of generation fuel for the objective function had been minimized by (3.43%), (3.72%), and (4.91%) in comparison to the conventional genetic algorithm for (100, 500, and 1000) iterations, respectively.

The outcomes of the suggested method for the three solutions for the control variables are presented in Table 3, they fluctuate between the lowest and maximum allowable bounds. of the system and at optimal values, which indicates that the suggested approach has yielded the anticipated outcomes in this regard.

IV. DISCUSSION

Three iterations (100), (500), and (1000) were used to obtain results from the proposed approach (800.84 \$/hour), (800.61 \$/hour), and (799.65 \$/hour), respectively, with the last iteration (1000) Leads to minimum total generation fuel cost, this indicates that the more the search space is expanded, the greater the likelihood of finding values for the optimal parameters that achieve the optimal value of the objective function.

These results have been verified by other studies published in the literature to ensure that the proposed approach meets the requirements of alternative and promising approaches such as the improved GA [4], enhanced GA [13], Particle Swarm Optimization (PSO) [14], and the conventional GA. Table 4, indicates that the proposed method produced accurate and high-quality outputs.

Table 3. The outcomes of the suggested method

Control variables	Max	Min	Conventional GA	Proposed GA		
				Iter=100	Iter =500	Iter =1000
Cost(\$/h)			803.6	800.84	800.61	799.64
P _{G1} (MW)	200	50	155.39	182.31	182.96	177.4
P _{G2} (MW)	80	20	40.57	44.33	41.95	49.54
P _{G5} (MW)	50	15	24.74	22.28	21.99	21.21
P _{G8} (MW)	35	10	37.09	20.36	22.60	20.12
P _{G11} (MW)	30	10	15.23	11.22	11.23	12.38
P _{G13} (MW)	40	12	18.01	12.2	12	12.05
P _{loss} (MW)			7.66	9.32	9.24	8.85
V _{G1} (pu)	1.1	0.95	1.06	1.09	1.08	1.09
V _{G2} (pu)	1.1	0.95	1.04	1.07	1.06	1.07
V _{G5} (pu)	1.1	0.95	1.02	1.03	1.029	1.04
V _{G8} (pu)	1.1	0.95	1.02	1.05	1.037	1.05
V _{G11} (pu)	1.1	0.95	1.05	1.063	1.05	1.09
V _{G13} (pu)	1.1	0.95	1.052	1.09	1.031	1.07
T ₁₋₁ (pu)	1.1	0.9	1.01	0.95	1.08	0.98
T ₁₋₂ (pu)	1.1	0.9	1.01	1.06	0.98	1.05
T ₁₋₅ (pu)	1.1	0.9	1.04	1.02	1.04	1.05
T ₃₋₆ (pu)	1.1	0.9	1.01	0.91	1.09	0.98
Q ₁₀ (MVar)	5	0	1.8	0.10	1.10	3.4
Q ₁₂ (MVar)	5	0	0	2.3	0.40	2.7
Q ₁₅ (MVar)	5	0	0	0.6	0.8	0.3
Q ₁₇ (MVar)	5	0	0	0.6	0.8	0.5
Q ₂₀ (MVar)	5	0	0	0.1	0.8	0.1
Q ₂₁ (MVar)	5	0	0	1.4	1.4	0.7
Q ₂₃ (MVar)	5	0	0	0.2	0.3	0.4
Q ₂₄ (MVar)	5	0	0.4	0.6	1.2	1
Q ₂₉ (MVar)	5	0	0	0.5	0.5	0

Table 4. Comparative of the fuel costs for various techniques

Method	Cost(\$/h)
Improved GA [4]	801.49
Enhanced GA [13]	802.06
PSO [14]	800.41
Conventional GA	803.6
Proposed GA (Iter=100)	800.84
Proposed GA (Iter=500)	800.61
Proposed GA (Iter=1000)	799.65

V. CONCLUSION

The GA was introduced as one of the AI techniques for determining the best solutions to many issues, such as OPF, and determining the best objective function solution. Parameters of algorithms that impact the generation of optimal solutions; are often set at fixed values, and with fixed values, the optimal solution is not achievable. This is what was proven in this study by expanding the area of the search space for those parameters to reach the optimal parameter that achieves the optimal solution.

The suggested approach yielded the lowest cost of generation fuel (799.65 \$/h), and the findings validated the suggested method's effectiveness. when compared to the other results documented in the literature. This indicates that the approach shows promise and is able to be extended for resolving additional objective functions or be used with different algorithms.

REFERENCES

- [1] P. M. Vasant, *Meta-heuristics optimization algorithms in engineering, business, economics, and finance*. IGI Global, 2012.
- [2] M. S. Osman, M. A. Abo-Sinna, and A. A. Mousa, "A solution to the optimal power flow using genetic algorithm," *Appl Math Comput*, vol. 155, no. 2, pp. 391–405, 2004.
- [3] A. F. Attia, Y. A. Al-Turki, and A. M. Abusorrah, "Optimal power flow using adapted genetic algorithm with adjusting population size," *Electric Power Components and Systems*, vol. 40, no. 11, pp. 1285–1299, Aug. 2012, doi: 10.1080/15325008.2012.689417.
- [4] L. L. Lai, J. T. Ma, R. Yokoyama, and M. Zhao, "Improved genetic algorithms for optimal power flow under both normal and contingent operation states," 1997.
- [5] A. G. Bakirtzis, P. N. Biskas, C. E. Zoumas, and V. Petridis, "Optimal power flow by enhanced genetic algorithm," *IEEE Transactions on power Systems*, vol. 17, no. 2, pp. 229–236, 2002.
- [6] S. Kahourzade, A. Mahmoudi, and H. Bin Mokhlis, "A comparative study of multi-objective optimal power flow based on particle swarm, evolutionary programming, and genetic algorithm," *Electrical Engineering*, vol. 97, no. 1, pp. 1–12, Mar. 2015, doi: 10.1007/s00202-014-0307-0.
- [7] D. Devaraj and B. Yegnanarayana, "A combined genetic algorithm approach for optimal power flow," in *Proc. 11th National Power system conf., Bangalore, India*, 2000, pp. 524–528.
- [8] S. Kahourzade, A. Mahmoudi, and H. Bin Mokhlis, "A comparative study of multi-objective optimal power flow based on particle swarm, evolutionary programming, and genetic algorithm," *Electrical Engineering*, vol. 97, pp. 1–12, 2015.
- [9] D. Devaraj and B. Yegnanarayana, "Genetic-algorithm-based optimal power flow for security enhancement," in *IEE Proceedings: Generation, Transmission and Distribution*, Nov. 2005, pp. 899–905. doi: 10.1049/ip-gtd:20045234.
- [10] A. Ali *et al.*, "Multi-objective Security Constrained Unit Commitment Via Hybrid Evolutionary Algorithms," *IEEE Access*, 2024.
- [11] O. S. Al-butti and O. T. Altinoz, "Comparison Between PSO-Based and fmincon-Based Approaches of Optimal Power Flow for a Standard IEEE-30 Bus System," in *International Symposium on Energy Management and Sustainability*, Springer, 2022, pp. 209–219.

- [12] O. Alsac and B. Stott, "Optimal load flow with steady-state security," *IEEE transactions on power apparatus and systems*, no. 3, pp. 745–751, 1974.
- [13] A. G. Bakirtzis, P. N. Biskas, C. E. Zoumas, and V. Petridis, "Optimal power flow by enhanced genetic algorithm," *IEEE Transactions on power Systems*, vol. 17, no. 2, pp. 229–236, 2002.
- [14] M. A. Abido, "Optimal power flow using particle swarm optimization," *International Journal of Electrical Power & Energy Systems*, vol. 24, no. 7, pp. 563–571, 2002.



Eğitimi Dönüştürmek: Yapay Zekânın Kişiselleştirilmiş Eğitim, Yönetsel Etkinlik ve Kapsayıcılık Üzerindeki Etkisi

Çağla ODUNCULAR¹, Eylül KABAKÇI GÜNAY², Meltem İNCE YENİLMEZ^{3*}

¹İktisat / İzmir Demokrasi Üniversitesi, Türkiye

²İktisat / İzmir Demokrasi Üniversitesi, Türkiye

³İktisat / İzmir Demokrasi Üniversitesi, Türkiye

*(melteminceyenilmez@gmail.com)

Özet – Yapay zekâ teknolojilerinin gelişimi, kalıcı sorunlara yaratıcı çözümler sağlayan devrim niteliğinde değişimlere yol açmıştır. Yapay Zekâ, her öğrencinin talebini, hızını ve öğrenme tercihlerini karşılamak için öğretim taktiklerini değiştiren, kişiselleştirilmiş öğrenmenin önemli bir bileşenidir. Yapay zekâ algoritmaları, akıllı ders verme sistemleri tarafından kişiselleştirilmiş geri bildirim ve yardım sağlamak, öğrencinin kavrama düzeyini ve performansını artırmak için kullanılır. Yapay zekâ ayrıca idari faaliyetlerin otomatikleştirilmesini kolaylaştırarak öğretmenlere işlerinin eğitimsel kısımlarına konsantre olmaları için daha fazla zaman tanır. Çalışma, eğitimde yapay zekâ ile ilgili olası etik sorunları ve zorlukları araştırmakta, bununla beraber dikkatli uygulamanın ve önyargıyı önlemenin gerekliliğini vurgulamaktadır. Yapay zekâ uyarlanabilir olduğundan, öğretim içeriği yeni trendlere ve öğrencilerin bireysel olarak ilerlemesine ayak uyduracak şekilde daima değişmektedir. Çalışma, yapay zekânın çeşitli öğrenme gereksinimlerini karşılayarak katılımı nasıl destekleyebileceğini araştırmaktadır. Ayrıca, öğrenci performansını analiz etmede ve değerlendirmede yapay zekâ destekli araçların nasıl kullanılabileceği konusu oldukça önemlidir. Bu sayede öğretmenlerin ve öğrencilerin iyileştirilmesi gereken alanları belirlemelerine yardımcı olunabilir. Yapay zekâ geliştikçe gelecekte eğitimin nasıl şekilleneceği üzerinde önemli bir etkiye sahip olması kaçınılmazdır. Bununla birlikte, adilliği ve kapsayıcılığı korurken yapay zekâdan tam olarak yararlanmak için sürekli araştırma, iş birliği ve etik çerçeveler gereklidir.

Anahtar Kelimeler – Eğitimde Yapay Zekâ, Yapay Zekâ ile Kişiselleştirilmiş Öğrenme, Yapay Zekâ Yoluyla Kapsayıcı Eğitim

I. GİRİŞ

Bu Eğitim, toplumun en önemli temel taşlarından biridir. Her zaman bilgi ve becerileri gelecek nesillere aktarmanın ve onların sürekli değişen bir dünyada başarılı olmalarına olanak sağlamanın bir yolu olmuştur. Ancak, dünya hızla gelişirken eğitimin de buna ayak uydurması gerekir. Yapay zekâ, eğitim sunumunun geleceğini şekillendirmek için en güçlü araçlardan biri olarak ortaya çıkmıştır. Yapay zekâ, bir makinenin insan zekâsını taklit etme ve deneyimlerden öğrenme yeteneği olarak tanımlanır. Eğitim ortamında bu, çocukların daha verimli ve kişiselleştirilmiş makine öğreniminden yararlanabileceğini gösterir. Sonuç olarak, yapay zekânın eğitimde nasıl devrim yarattığını ve gelecekte sınıfları nasıl etkileyeceğini anlamak kritik bir önem taşımaktadır.

Yapay zekâ, işgücü ve eğitim sektörlerini yeniden şekillendirmektedir. Yapay zekâ, eğitimsel engellerin üstesinden gelmek ve sürdürülebilir kalkınma hedeflerinden dördüncüsü olan (SDG 4) Nitelikli Eğitim'e doğru ilerlemeyi hızlandırmak için etkili bir teknik olarak ortaya çıkmıştır. Yapay zekâ, verileri toplayıp analiz ederek öğretmenlerin öğrencilerinin akademik performansını, katılımını ve genel refahını anlamalarına yardımcı olabilir. Yerleşik dijital araçlar ve uygulamalar, bireysel ilerlemeyi takip ederken öğretmenlerin ve öğrencilerin katılımını mümkün kılar.

Yapay zekâ, kişiselleştirilmiş öğrenme algoritmalarını kullanarak eğitimi önemli ölçüde değiştirme yeteneğine sahiptir. Yapay zekânın her öğrencinin güçlü ve zayıf yönlerini değerlendirme yeteneği

sayesinde eğitim materyalleri her öğrencinin özel ihtiyaçlarına daha uygun hale getirilebilir. Uzak konumlardan gelen öğrencilerin ilgisini çekmek veya geçmişte kullanılması halinde ciddi çevresel zarara yol açabilecek tarihi yerleri vurgulamak için sınıftan ayrılmadan sanal gerçeklik deneyimleri oluşturulabilir. Bu, öğrencileri etkileşimli bir öğrenme ortamına yerleştirerek anlama ve akılda tutmayı teşvik eder.

Öğrenciler, sanal şeylerle daha önce mümkün olmayan şekillerde etkileşime girmelerine olanak tanıyan yapay zekâ destekli artırılmış gerçeklik teknolojisi sayesinde öğrenmeyi daha etkileyici bulabilirler. Eğitimciler, cep telefonları gibi cihazları kullanarak gerçek zamanlı bilgileri sınıftaki akıllı tahtalara veya ekranlara yansıtarak, bireylerin bilgiyi verimli bir şekilde aktarma şeklini dönüştürerek yeni kapsayıcı deneyimler yaratabilirler.

Teknolojinin oldukça önemli faydalarına rağmen, politika yapımcıların eğitimde teknolojinin yaygın olarak kullanılmasıyla ilgili tehlikelerin farkına varmaları gerekir. Hassas veriler kullanıldığında gizlilik ve eşitlikle ilgili endişeler ortaya çıkabilmektedir. Bu nedenle, bu verilerin toplanması, saklanması ve paydaşlarla paylaşılması için şeffaf protokollere ihtiyaç vardır. Paydaşların, diğer kaygıların yanı sıra yaratıcılığı, eleştirel düşünmeyi ve çeşitliliği bastıran müfredat ve eğitim yöntemlerinde yer alan önceden var olan önyargıları ve alışkanlıkları güçlendirmek yerine, pedagojik hedeflerini genişletmek için teknolojik yenilikleri kullanıp kullanmadıklarını eleştirel bir şekilde değerlendirmeleri kritik öneme sahiptir.

Yapay zekâ iş dünyasında zaten popüler olmasına rağmen eğitim sektörünün hem öğretme ve öğrenme sürecinde hem de genel kampüs yönetiminde de ilgi görmektedir [1]. Yapay zekâ, 1956 yılında John McCarthy'nin Amerika Birleşik Devletleri'ndeki Dartmouth College'da yürüttüğü bir atölye çalışmasıyla başlamıştır. Bir makinenin öğrenmenin herhangi bir bileşenini nasıl taklit edebileceğini göstermek için yapay zekâ ifadesini icat etmiştir [2]. Luckin ve diğ. [3], yapay zekânın 1970'ten bu yana eğitimde kullanıldığını, öncelikli olarak kişiselleştirilmiş öğrenmeye olanak tanıyan bilgisayar programlarının yanı sıra otomatik değerlendirme ve geri bildirim sistemleri geliştirmeye odaklandığını ileri sürmektedir. Bu da yapay zekânın yeni bir kavram olmadığını daha ziyade her zaman var olduğunu gösterir. Bununla birlikte terim, yakın zamanda kabul görmeye ve yayılmaya başlamıştır. Ayrıca Miao ve diğ. [4], politika yapımcıların politika geliştirmelerine ve yapay zekânın eğitimdeki potansiyel uygulamaları ve sonuçlarını daha iyi anlamalarına yardımcı olmayı amaçlayan Politika Yapımcılar için UNESCO 2019'da [5] Yapay Zekâ ve Eğitim Kılavuzlarını geliştirmiştir. Çalışmada, yapay zekânın eğitim bağlamlarında kullanımının, yüksek kaliteli, kapsayıcı ve eşitlikçi eğitime evrensel erişimin yanı sıra yaşam boyu öğrenme olanaklarını talep eden Sürdürülebilir Kalkınma Hedefi 4 [6] ile uyumlu olmasını sağlamak amaçlanmıştır. Miao ve diğ. [4] göre, UNESCO bu kılavuzu politika yapımcıların yapay zekânın öğretme ve öğrenmeye yönelik potansiyelini ve yansımalarını anlamalarına yardımcı olmak için geliştirmiştir. Yapay zekânın Sürdürülebilir Kalkınma Hedefi 4'ü desteklemesi için, yapay zekâ teknolojilerini geliştirmeye yönelik düşük maliyetli modellerin kullanıma sunulması, düşük ve orta gelirli ülkelerin çıkarlarının anlamlı tartışma ve kararlarda temsil edilmesi ve bunlar arasında bağlantılar kurulması gerekmektedir.

Yapay zekâ, kişiselleştirilmiş öğrenme, otomatik değerlendirme sistemleri, işbirlikçi öğrenme ve akıllı öğretim gibi çeşitli uygulamalar yoluyla eğitimi iyileştirme konusunda önemli bir potansiyele sahiptir [7]. Yapay zekâ tüm öğrenci kitlesi için daha ölçeklenebilir hale gelmekte ve kişiselleştirilmiş eğitimi mümkün kılmaktadır. Takviyeli öğrenme gibi yapay zekâ yaklaşımları kullanılarak öğrencilerin ihtiyaçları sürekli olarak tespit edilebilir ve öğrenme süreci değiştirilebilir. Öğretimin kişiye göre uyarlanması, hassas geri bildirim ve aktif öğrenci katılımına sahip akıllı öğretim sistemlerinin geliştirilmesine yol açabilir. Yapay zekânın bir diğer önemli özelliği de, otomatik değerlendirme sürecidir.

Bilgisayarlı görme ve doğal dil işleme sistemleri, ödevleri, sınavları ve kısa sınavları otomatik olarak değerlendirmek için birleştirilebilir. Otomatik not verme, öğretmenlerin işlerini daha kolay hale getirerek onlara öğrencilerle etkileşimde bulunmaları için daha fazla zaman tanıyacaktır. Yapay zekâ ayrıca çeşitli ölçümler ve geri bildirimler sunarak öğrencilerin ve öğretmenlerin iş birliği yapmasına da yardımcı olabilir. Yapay zekânın eğitimde uygulanması, akıllı sistemlerin potansiyel faydalarını örneklemektedir. Yapay zekânın etkisi, diğer avantajların yanı sıra, iyileştirilmiş öğrenme sonuçlarında, zaman ve maliyet tasarruflarında, yüksek kaliteli eğitime erişimin artmasında açıkça görülebilir.

Akıllı ders verme yöntemleri ve kişiye özel öğrenme, özellikle yetersiz hizmet alan topluluklarda öğrencilerin daha iyi öğrenme sonuçları elde etmelerine yardımcı olabilir. Yapay zekânın küresel erişimi

ve ölçeklenebilirliği hem zengin hem de yoksul ülkelerdeki öğrencilerin öğrenme deneyimlerini artıracaktır. Otomatik not verme, eğitimde zamandan ve paradan tasarruf sağlayacaktır. Not verme ve diğer ilgili faaliyetler şu anda öğretmenin zamanının önemli bir kısmını kullanmaktadır. Eğitimcilerin not verme işleriyle ilgili yüklerinin azaltılması, eğitimcilerin öğrencilerle buluşma ve öğrencilere ek öğrenim yardımı sağlama konusunda daha fazla zaman yaratmasını sağlayacaktır.

Daha önce yeni teknolojilerin kötüye kullanılması olasılığı vardı. Nükleer fizyonun keşfi, yıkıcı nükleer silahların geliştirilmesini mümkün kılmıştır. İnternetin gelişi, yasa dışı ve suç teşkil eden eylemlerin hükümetten gizlenebileceği karanlık ağın oluşmasına olanak tanımıştır. Ancak uluslararası iş birliği ve kanun yaptırımı, toplumun teknoloji sömürsü tehlikesini azaltmasına yardımcı olmuştur. Çağdaş teknolojinin yararları sıklıkla dezavantajlarından daha ağır basmaktadır. Genel olarak, yeni yapay zekâ teknolojisini müfredata dahil etmek, eğitim alanındaki gelişimini engellemekten daha faydalı olacaktır.

II. YAPAY ZEKANIN EĞİTİM SİSTEMİ İÇİN FAYDALARI

Kişiselleştirilmiş öğrenme, yapay zekânın eğitimdeki çeşitli avantajlarından biridir. Yapay zekâ destekli sistemler, her öğrencinin bireysel ihtiyaçlarına ve öğrenme tercihlerine göre özel olarak uyarlanmış ders planları ve değerlendirmeler geliştirebilir. Bu, öğrencilerin eğitimden en iyi şekilde yararlanmasını sağlayarak motivasyonu ve üretkenliği artırır. Ayrıca yapay zekâ, özel ihtiyaçları olan kişilerin eğitime erişimini iyileştirebilir. Yapay zekâ kullanan robotlar, öğrencinin ihtiyaç duyduğu alanları tespit edip akıllı ders verme çözümlerini kullanarak bu alanlarda özel eğitim sunabilmektedir. Yapay zekânın eğitimdeki bir diğer avantajı ise, problem çözme yeteneklerini gerçek zamanlı olarak analiz edebilmesidir. Bu teknolojiyi kullanarak eğitimciler, öğrencilerinin konuyu ne kadar iyi anladıklarını belirlemek için her öğrencinin bir ders veya kurs sırasındaki ilerlemesini izleyebilirler. Sorunları tespit edip hedefe yönelik çözümler önererek daha fazla dikkat gerektiren alanları belirlerler.

Yapay zekâyı eğitimde kullanmanın en önemli faydalarından biri, kişiye özel öğrenmeyi mümkün kılmasıdır. Yapay zekâ sistemleri, öğrencilerin öğrenme tercihleri, stilleri ve akademik başarılarına ilişkin büyük miktarda veriyi analiz edebilir. Bu veriye dayalı yöntem, ders planlarını ve uyarlanabilir öğrenme modüllerini her öğrenciye göre uyarlamak için kullanılabilir. Yapay zekâ, her öğrencinin bireysel taleplerini karşılayarak öğrenmeyi daha verimli ve kişisel hale getirir. Öğrenciler kendi öğrenme stillerine en uygun içerikle etkileşime geçebilir, kendi hızlarında çalışabilir ve materyali daha derinlemesine kavramak için gerektiğinde özel koçluk alabilirler.

Yapay zekâ, eğitimde çeşitliliğin ve erişilebilirliğin artırılmasına yardımcı olur. Yapay zekâyı kullanan akıllı ders verme sistemleri, öğrenme boşluklarını belirleyebilir ve bilgileri çok çeşitli öğrenme ihtiyaçlarını karşılayacak şekilde uyarlayabilir. Yapay zekâ, ek kaynaklar, etkileşimli teknolojiler veya alternatif öğrenme yolları sağlayarak belirli ihtiyaçları veya engelleri olan çocuklara yardımcı olur. Bu kapsayıcı yaklaşım, yetenekleri ne olursa olsun tüm öğrencilerin eğitim fırsatlarına ve kaynaklarına eşit erişime sahip olmasını garanti eder. Yapay zekâ destekli teknolojiler, engelleri aşmak ve daha eşitlikçi eğitim ortamlarını teşvik etmek için kritik bir öneme sahiptir.

Yapay zekânın yanı sıra gerçek zamanlı değerlendirme ve geri bildirim sağlama yeteneği, eğitimcilerin öğrencilerin ilerlemesini izleme şeklini değiştirir. Yapay zekâ sistemleri, devam eden verileri analiz ederek her öğrencinin ilerlemesini gerçek zamanlı olarak izleyebilir. Öğretmenler, öğrencilerin başarılı veya başarısız olabileceği alanları keşfetmek ve ardından bu sorunları çözmede hemen harekete geçmek için bu hızlı geri bildirim döngüsünü kullanabilir. Bir öğrenci daha ileri düzeydeki bir konuya hazır olduğunda, öğretmenler ileri düzey temalar atayabilir veya belirli endişeleri gidermek için ders planlarını değiştirebilir. Bu dinamik değerlendirme sisteminin iki avantajı vardır: öğrenmeyi geliştirir ve daha özel ve etkili öğretim yöntemlerinin uygulanmasına olanak tanır.

Eğitimciler bilinçli kararlar vermek için gelişmiş veri analizi araçlarını ve yapay zekâyı kullanabilir. Yapay zekâ, öğretmenlere katılım ve akademik performansla ilişkin verilerin toplanması ve analizi yoluyla kalıpları ve eğilimleri belirlemede yardımcı olur. Bu veriye dayalı anlayış, daha etkili müfredat tasarımı, kaynak tahsisi ve öğretim uygulamalarına yol açmaktadır. Öğretmenler, öğretim yöntemlerinin başarısını değerlendirebilir, daha fazla dikkat edilmesi gereken alanları belirleyebilir ve eğitimin genel kalitesini artırmak için mevcut en iyi verilere dayanarak kararlar verebilir. Öğretmenler analitik bir yaklaşım

kullanarak tekniklerini sürekli geliştirebilir ve öğrencilerinin değişen gereksinimlerine uyum sağlayabilirler.

Son olarak, yapay zekâ araştırmalarında SLAM olarak bilinen makine görme algoritmalarına yönelik ilerlemeler, sürükleyici sanal gerçeklik (VR) deneyimlerinin yaratılmasını mümkün kılmıştır. Bilgisayarların kamera girişinden harita oluşturmaya olanak tanıyan yöntemler sayesinde Pokémon Go gibi sanal gerçeklik oyunları artık mümkün hale gelmiştir. Güney Kaliforniya Üniversitesi Yaratıcı Teknolojiler Enstitüsü, eğitim tatbikatları sırasında talimatları okumak yerine bu simülasyonları kullanmanın, birliklerin yeni becerileri hızlı bir şekilde öğrenmesine yardımcı olduğunu keşfetmiştir. Her şey göz önüne alındığında, yapay zekânın avantajları eğitim ve öğrenmeyi değiştirmekte; özel koşulları ne olursa olsun, çocuklara her yerde çok çeşitli fırsatlar sunmaktadır.

III. ÖĞRETİMDE YAPAY ZEKA

Öğretim, yalnızca materyal sunumunu değil aynı zamanda sosyal ve duygusal becerilerin geliştirilmesini de gerektiren karmaşık ve her şeyi kapsayan bir faaliyet olduğundan, yapay zekânın öğretmenlerin ve eğitmenlerin tamamen yerini alması pek olası değildir [8]. Ayrıca Chan ve Tsi [9], bazı katılımcıların yapay zekânın eninde sonunda öğretmenlerin yerini alacağına dair inançlarına rağmen, "gelişen yapay zekâ teknolojileri karşısında eğitimcilerin gelecekteki rolü" konulu araştırmalarında katılımcıların çoğunluğu, eğitmenlerin eleştirel düşünme, yaratıcılık ve duygu düzenleme konusundaki benzersiz becerileri nedeniyle yerlerinin doldurulamayacağını belirtmişlerdir.

Çalışma aynı zamanda yapay zekâ sistemlerinin artık kopyalayamadığı kişilerarası etkileşimler yoluyla kazanılan sosyal ve duygusal yeteneklerin öneminin de altını çizmektedir [9]. Bulgulara göre öğretmenler, yapay zekâyı geleneksel öğretim yaklaşımlarının yerine koymadan, derslerine etkili bir şekilde dahil edebilirler. Bunu başarmak için eğitimcilerin yapay zekâ okuryazarlığının farkına varmaları, yapay zekânın risklerden kaçınırken eğitmenler ve öğrencilerle nasıl etkili bir şekilde iş birliği yapabileceğini anlamaları, gizlilik, etik ve veri güvenliği gibi ilgili endişeleri ele almaları gerekir [9]. Yapay zekâ, oyunlaştırma, kapsamlı öğrenme, fikir oluşturma, uyarlanabilir öğrenme, iki dilli eğitim, özel ihtiyaç eğitimi ve kişiselleştirilmiş öğrenme dahil olmak üzere çeşitli alanlarda eğitimi iyileştirme konusunda önemli bir potansiyele sahiptir.

Kişiselleştirilmiş öğrenme, her öğrencinin ihtiyaçlarına göre uyarlanmış ders planları oluşturmak ve öğrencinin öğrenme stili ile güçlü ve zayıf alanlarına göre kaynaklar önermek için yapay zekâ destekli algoritmalar kullanır. Uyarlanabilir öğrenme platformları, her öğrencinin ilerlemesine anında yanıt verebilir, bilgi eksikliği olan alanları tespit edebilir, zamanında geri bildirim sağlayabilir ve öğrencilerin materyali anlamalarına yardımcı olmak için hedefe yönelik müdahaleler önerebilir. Eğitimciler, idari görevleri otomatikleştirmek için yapay zekâyı kullanarak öğretmeye ve öğrenci etkileşimine daha fazla odaklanabilirler. Kişiselleştirilmiş öğrenme programları, olağanüstü ihtiyaçları olan öğrencilerin tam potansiyellerine ulaşmalarına yardımcı olabilir ve öğrenciler, yapay zekâ destekli sanal öğretmenlerden 24 saat destek alabilir. Oyunlaştırma ve yoğunlaştırılmış öğrenim, öğrencilerin ilgisini, memnuniyetini ve kalıcılığı artırma gücüne sahiptir.

Yapay zekâ destekli dil çeviri sistemleri, diğer ülkelerden veya dillerden eğitimciler ve öğrenciler arasında bilgi paylaşımını ve iş birliğini kolaylaştırarak iletişim engellerini azaltma potansiyeline sahiptir. Yapay zekâ eğitimi, çocukların dijital okuryazarlığını geliştirmek, eleştirel düşünme becerilerini geliştirmek ve onları gelecekte sınıfta ve iş gücünde başarıya hazırlamak için gereklidir. Öğrenciler yapay zekâ sistemlerine ilişkin temel bir kavrayışa sahip olduklarında yapay zekâ teknolojileriyle güvenli, etik ve sorumlu bir şekilde iş birliği yapabilir ve bunlarla etkileşime geçebilirler. Yapay zekâ okuyan öğrenciler aynı zamanda karmaşık bilgileri değerlendirmek, varsayımları sorgulamak ve AI teknolojisini uygulamanın etik sonuçlarını dikkate almak zorunda kalmaktadırlar. Yapay zekâ işgücü piyasasını dönüştürdüğü için yapay zekâ ve ilgili alanlarda deneyime sahip profesyonellere olan ihtiyaç artmaktadır. İşverenler öğrencilere yapay zekâyı öğretmek onların teknoloji, veri bilimi ve diğer yüksek talep gören sektörlerde kariyer yapmaları için gerekli bilgi ve becerileri edinmelerine yardımcı olabilir. Yapay zekâ eğitimi, öğrencilerin fikir üretmesini ve problem çözmesini teşvik edebilir; bu da günümüzün rekabetçi ve hızlı iş piyasasında önemli olan iki özellik olan yaratıcılığın ve yenilikçiliğin gelişmesine yardımcı olabilir.

Öğrencileri yapay zekâ eğitimi almaya teşvik etmek, yapay zekâ ve ilgili alanlardaki beceri açığının kapatılmasına ve yetenek havuzunun çeşitlendirilmesine yardımcı olabilir, aynı zamanda küresel iş gücünde başarılı olmak için gereken beceri ve bilgiye sahip olmalarını da garanti edebilir. Yapay zekâ teknolojisindeki ve çözüm geliştirmedeki çeşitlilik, yaratıcılığın, yenilikçiliğin ve problem çözme yeteneklerinin artmasına yol açabilir. Yeterince temsil edilmeyen nüfuslar, teknolojiyi toplumsal iyilik için kullanma ve yerel ve küresel ölçekte faydalı değişiklikler sağlama konusunda daha yetenekli hale gelerek yapay zekâ eğitiminden yararlanabilir. İnternetteki bağnazlık ve ayrımcılıkla mücadelede geniş bir yelpazedeki değerlere saygı gösterilmesini sağlamak için bu alana çeşitlilik, eşitlik ve katılım getirilmelidir. Özetlemek gerekirse, yeterince temsil edilmeyen grupların yapay zekâ konusunda bilgi sahibi olmalarını sağlamak, onların yapay zekâ kullanımını yöneten kural ve düzenlemeleri etkileyerek politikaların ve seçimlerin oluşturulmasında yer almasına olanak tanır.

IV. ERİŞİLEBİLİRLİK VE EŞİTLİK İÇİN YAPAY ZEKADAN FAYDALANMA

Holstein ve Doroudi'ye [10] göre yapay zekâ sistemlerinin geliştirilmesinin, öğrenci grupları arasındaki başarı farklarını ortadan kaldırması ve eğitim eşitliğini ilerletmesi beklenmektedir. Popenici ve Kerr [11] ayrıca makine öğrenimi algoritmalarını kullanan yapay zekâ sistemlerinin çeşitli kapasitelerdeki bireylere yardımcı olabileceğini ve bunun yükseköğretim kurumları için yeni bir çağın başlangıcına işaret ettiğini belirtmiştir. Yapay zekâ, herkesin yüksek kaliteli eğitime erişimini sağlamayı ve yaşam boyu öğrenme fırsatlarını teşvik etmeyi amaçlayan Sürdürülebilir Kalkınma Hedefi 4 doğrultusunda tüm öğrencilerin eğitime eşit erişime sahip olmasını sağlayabilmeyi mümkün hale getirir [5]. Bu, engelliler, mülteciler, okuldan ayrılanlar ve uzak bölgelerde yaşayanlar gibi dışlanmış insanlara ve topluluklara yeterli öğrenme fırsatları sunulması olarak gerçekleştirilir.

UNESCO'ya [5] göre, eğitimde yapay zekâyâ ilişkin politikalar formüle edilirken eşitliğin ve katılımın önceliklendirilmesi çok önemlidir. Az gelişmiş ülkelerdeki dijital uçurumun kapatılmasına yönelik yasal tedbirlerin oluşturulmasında ilk adım bizzat hükümetlerden gelmelidir. Örneğin Bangladeş'te hükümet her vatandaşın 4 km uzakta dijital merkezler kurmuştur [12]. Benzer şekilde, "öğrenci başına bir dizüstü bilgisayar" ve internet erişimi sağlamayı amaçlayan bir Uruguay girişimi olan Ceibal planı, başlangıçta eğitimi dijitalleştirmenin bir aracı olarak önerilmiş ancak daha sonra ulusal bir sosyal adalet stratejisine dönüşmüştür [13].

Yapay zekâ, eşitsizlikleri gidererek ve boşlukları kapatarak eğitimde eşitlik ve erişilebilirliğin geliştirilmesinde hayati bir rol oynamaktadır. Uyarlanabilir öğrenme sistemleri gibi yapay zekâ destekli araçlar, çeşitli öğrenme ihtiyaçları olan öğrencilere özel içerik ve destek sağlayabilir. Örneğin Knewton, her öğrencinin uygun düzeyde içeriğe tabi tutulmasını garanti etmek için öğretim materyallerini her öğrencinin performansına göre uyarlar. Oyun alanı eşitlenir ve bu çocuklar, bu özelleştirilebilir yaklaşımla kendi benzersiz ihtiyaçlarına göre hazırlanmış iyi bir eğitim alabilirler.

Yapay zekâ, akademik açıdan risk altında olabilecek öğrencilerin zamanında tespit edilmesini kolaylaştırarak olası eşitsizlikleri azaltmak için özelleştirilmiş müdahalelere olanak tanır. Tahmine dayalı analitik ve makine öğrenimi algoritmaları, hangi öğrencilerin ek destekten yararlanacağını belirlemek için katılım, notlar ve devam gibi çeşitli veri ölçümlerini inceler. Eğitimciler bu erken uyarı sistemini kullanarak, tehlike altındaki çocukların özel stratejiler ve müdahaleler sunarak ihtiyaç duydukları yardımı almalarını sağlayabilirler. Yapay zekâ odaklı girişimler, eğitim kurumlarının eşitlik sorunlarını ele almasına ve öğrenci kitlesinin ihtiyaçlarını karşılamasına yardımcı olabilir.

V. EĞİTİMDE YAPAY ZEKANIN ZORLUKLARI VE KAYGILARI

Yapay zekânın eğitime entegrasyonu, yasalar ve politikalarla ilgili tartışmaların ötesine geçen bir dizi endişeyi ve zorluğu gündeme getirmiştir. Ana endişelerden biri mahremiyetin ihlalidir; bu sebeple öğretmenler ve öğrenciler yapay zekâ teknolojileri hakkında pek iyi düşünmeyebilirler. Bu yüzden, teknolojinin nimetlerinden yararlanılırken veri güvenliğinin korunmasına yönelik tedbirlerin alınması gerekmektedir. Bir diğer önemli engel ise, yapay zekâ destekli platformların ve teknolojinin erişilebilirliğidir. Teknolojiyi erişilebilir kılmak için, buldukları yer ve sosyoekonomik statüleri ne olursa olsun herkese eşit olanaklar sağlanmalıdır. Ancak bazıları, yapay zekânın sınıftaki önyargıları ve ayrımcılık

biçimlerini meşrulaştıracağından endişe etmektedir. Bu genellikle, belirli kültürler veya etnik gruplarla ilişkili idealleri kasıtlı olarak destekleyen veya desteklemeyen kişiselleştirilmiş öğrenme materyalleri kullanıldığında meydana gelir.

Bölge yöneticilerinin ve yasa koyucuların yapay zekâ teknolojilerinin tüm potansiyel faydalarının ve risklerinin dikkate alındığından emin olmaları gerekir. Öğrencilerin kişisel bilgilerinin alınmasını gerektiren özelleştirilmiş öğrenme teknolojilerini kullanırken bilgilendirilmiş onam gerekli olduğundan, bunu teşvik etmeleri gerekir. Eğitim kurumlarındaki bu etik ikilemlerle baş etmenin en iyi yolu şeffaflık normlarını desteklemektir.

Yapay zekâ, öğretim stratejilerinin etkisiz gelişimi de dahil olmak üzere eğitim alanında bir dizi engeli aşma potansiyeline sahiptir. Ulusal Eğitim Sisteminde otomatik notlandırma sistemlerini uygulamadan önce yapılması gereken tüm hususlar göz önüne alındığında, hala birçok bilinmeyen vardır, çünkü etkili bir değerlendirme şu anda notlar veya yalnızca öğretmenlere yönelik değerlendirmeler gibi geleneksel ölçümler kullanılarak belirlenmemektedir.

VI. EĞİTİMİN YAPAY ZEKA DESTEKLİ GELECEĞİNE İLİŞKİN SON AÇIKLAMALAR

Yapay zekâ insanların öğrenme ve öğretme şeklini değiştirmektedir. En güncel teknolojiye sahip eğitim içeriği sağlama, idari görevleri otomatikleştirme, öğrenimi özelleştirme ve çok daha fazlasını sunabilme yeteneğiyle yapay zekâ, eğitim alanında yeni olanakların önünü açmaktadır. Ancak, ahlaki ikilemlerle yüzleşmek gerekir ve sürekli değişim geçiren bir toplumda eğitimin bir fırsat ve ilerleme ışığı olarak kalmasını sağlamak zorunludur. Eğitim ortamı değiştikçe yapay zekâ daha kişiselleştirilmiş, verimli ve kapsayıcı öğrenme fırsatlarının önünü açmaktadır. Eğitimin geleceği yapay zekâdaki ilerlemelerle şekillenmektedir. Toplum bir bütün olarak bu değişimi kabul etmeli ve sürekli değişen dünyada eğitimin bir fırsat ve ilerleme kaynağı olmaya devam etmesini sağlamak için birlikte çalışmalıdır.

Yapay zekâ, eğitimi tamamen dönüştürme ve sektörün kalıcı sorunlarının çoğunu çözme potansiyeline sahiptir. Yapay zekâ eğitiminin dünya genelindeki okullarda önemli bir geleceği vardır. Yapay zekânın eğitimcilerin iş yükünü hafifletme ve idari görevleri hızlandırma kapasitesi, teknolojinin sınıftaki ana avantajlarından biridir. Yapay zekâ, akıllı ders programları, otomatik not verme ve kişiselleştirilmiş öğrenme dahil olmak üzere eğitimi birçok yönden dönüştürmektedir. Sıradan işler otomatikleştiğinde öğretmenler eğitimin daha yaratıcı alanlarına veya öğrencilerle birebir etkileşimlere odaklanabilirler. Öte yandan yapay zekâ tabanlı eğitim kaynaklarının etkinliği konusunda şüpheler var. Bu teknolojiler, kişiye özel geri bildirimler sunsalar bile insan etkileşimlerini mükemmel şekilde taklit edemeyebilir. Öğrenci verilerinin toplanmasının ahlaki kullanımı için politika tartışmaları ve yasal çerçeveler de gereklidir.

Bazı çekincelere rağmen yapay zekânın üretimi artırma ve eğitimi iyileştirme konusunda büyük umut vaat ettiği açıktır. Eğitim kurumları yapay zekâ çözümlerinin mümkün kıldığı en ileri teknolojiyi benimsemeye devam ettikçe bu sektörde daha fazla büyüme beklenebilir. Bu büyüme, öğretmenler ve öğrenciler arasındaki etkili iletişimi kolaylaştırmaya ve öğrenme ister sanal ortamda ister geleneksel sınıf ortamlarında gerçekleşsin akran sosyalleşmesini teşvik eden akıllı sistemler geliştirmeye odaklanacaktır.

KAYNAKLAR

- [1] Dhawan, S. and Batra, G. (2021). Artificial intelligence in higher education: Promises, perils, and perspective. *OJAS*, 11-21.
- [2] Pedró, F. (2020). Applications of artificial intelligence to higher education: Possibilities, evidence, and challenges. *Open Journal of IUL University*, 1(1), 61-76.
- [3] Luckin, R., Holmes, W., Griffiths, M. and Forcier, L. B. (2016). *Intelligence Unleashed. An argument for AI in Education*. London: Pearson.
- [4] Miao M., Zheng L. and Gan Y. (2021). The future-oriented function of meaning in life: Promoting hope via future temporal focus. *Personality and Individual Differences*, 179, 110897
- [5] UNESCO. (2019). *Artificial intelligence in education: Challenges and opportunities for sustainable development*.
- [6] Mhlanga, D. (2021). Artificial Intelligence in the industry 4.0, and its impact on poverty, innovation, infrastructure development, and the Sustainable Development Goals: Lessons from emerging economies? *Strides in Development of Medical Education*, 14(3), 1-6.
- [7] Wollny, S., Schneider, J., Di Mitri, D., Weidlich, J., Rittberger, M., and Drachler, H. (2021). Are we there yet? -A systematic literature review. *Front. Artif. Intell.* 4, 654924

- [8] Kolchenko, V. (2018). Can modern AI replace teachers? not so fast! artificial intelligence and adaptive learning: Personalized education in the AI age. *HAPS Educator*, 22(3), 249–252.
- [9] Chan, C. And Tsi, L. (2023). The AI revolution in education: Will AI replace or assist teachers in higher education? *Computers and Society*.
- [10] Holstein, K. And Doroudi, S. (2021). Equity and artificial intelligence in education: Will "AIEd" amplify or alleviate inequities in education? <https://doi.org/10.48550/arXiv.2104.12920>
- [11] Popenici, S. A. and Kerr, S. (2017). Exploring the impact of artificial intelligence on teaching and learning in higher education. *Research and Practice in Technology Enhanced Learning*, 12(1). <https://doi.org/10.1186/s41039-017-0062-8>
- [12] Chowdhury, A. (2022). The 4th Industrial Revolution must close the digital divide. Retrieved from <https://news.cgtn.com/news/2022-03-19/The-4th-IndustrialRevolution-must-close-the-digital-divide-18wD0ITuWfm/index.html>
- [13] Pombo, C., Gupta, R., and Stankovic, M. (2018). Social Services for Digital Citizens: Opportunities for Latin America and the Caribbean. Retrieved from <http://dx.doi.org/10.18235/0001105>.



Design Optimization of Blade Antenna using Deep Learning Surrogates

Eysem Yılmaz^{*}, Mehmet Ali Belen²

^{1,2} Department of Electric and Electronic Engineering, Iskenderun Technical University, Iskenderun 31200, Turkey

*eysemyilmaz@gmail.com

Abstract –The design of blade antennas, characterized by their slender, planar, and aerodynamic structure, is crucial for ensuring optimal performance in high-speed communication platforms such as aircraft and missiles. These antennas are favored for their low-profile, which minimizes air resistance, and their capability to operate across a wide range of frequencies due to their vast bandwidth and omnidirectional pattern. Despite their advantages, the design process of blade antennas is challenged by the limitations imposed by their physical dimensions, which can affect their frequency range and aerodynamic performance, alongside the complexities and costs associated with their design and manufacturing. The traditional approach to antenna design, reliant on extensive simulations and iterative testing, is both time-consuming and resource-intensive. This study explores the application of deep learning, a subset of machine learning characterized by artificial neural networks, as a transformative approach for the design optimization of blade antennas. Deep learning presents a promising avenue for modeling the intricate relationships between design parameters and performance outcomes, thereby facilitating the exploration of new optimization paths previously unachievable with conventional methods. This paper aims to demonstrate how deep learning can revolutionize the antenna design process, reducing the reliance on iterative physical prototypes and paving the way for more efficient, effective, and innovative antenna development strategies. Through the integration of advanced computational models with empirical antenna design knowledge, the research seeks to unveil novel methodologies that enhance both the performance and aerodynamic efficiency of blade antennas in military and civilian applications.

Keywords – Optimization, Blade Antenna, Deep Learning, Surrogate modeling.

I. INTRODUCTION

A blade antenna is characterised by its slender, planar, and aerodynamic structure, which bears a resemblance to the blade of a knife [1]. This design facilitates convenient mounting on aircraft fuselages, missiles, and other high-speed platforms, where the attainment of aerodynamic performance is of paramount importance. Blade antennas function based on the fundamental concept of emitting and receiving electromagnetic waves, commonly within the wavelength ranges of Very High Frequency (VHF) and Ultra High Frequency (UHF). Their design is specifically developed to reduce resistance and endure the harsh conditions seen during high-speed operations [2-3]. The extensive deployment of blade antennas across numerous fields can be attributed to their versatility and robustness. Their uses have been thoroughly documented in the literature, emphasising their importance in both military and civilian domains. The military sector encompasses several applications such as navigation, air-to-ground communication, and missile guidance systems, wherein the utmost importance is placed on reliability and compactness. The antenna's versatility to many conditions and requirements is seen in its wide range of civilian uses, including commercial aircraft, communication and navigation systems, and in certain cases, automotive and maritime communications. The distinctive appearance and operation of the blade antenna offer numerous advantages. Due to its low-profile and aerodynamic design, this object exhibits reduced vulnerability to air resistance, rendering it highly suitable for high-speed applications. The vast bandwidth and omnidirectional design of the antenna provide dependable communication over a diverse spectrum of

frequencies. Moreover, its sturdy structure offers resilience in the face of challenging working situations, guaranteeing long-lasting performance and dependability. Nevertheless, the blade antenna does have its constraints. The antenna's frequency range can be limited by its physical dimensions, especially at lower frequencies when a bigger size would be more effective. Furthermore, although the antenna is specifically engineered to have a low-profile, its positioning on the exterior of a vehicle can still have an influence on the aerodynamic performance to a certain extent. Furthermore, the intricate nature of its design and production procedures can result in increased expenses, hence diminishing its economic viability for some applications.

The investigation of creative approaches has been driven by the difficulty of optimising design parameters of antennas to fulfil ever intricate requirements. Deep learning is a highly effective method that demonstrates exceptional capabilities in the design and optimization of crucial components such as blade antennas. Blade antennas play a crucial role in the aerospace and defence industries because to their slender and aerodynamic design, enabling vital communication [4-10], navigation, and radar functionalities. The architecture of these platforms plays a crucial role in determining both their performance and aerodynamic efficiency. Nevertheless, the conventional approach to designing blade antennas entails the utilisation of comprehensive simulations and iterative testing, resulting in a significant investment of time and resources. The process of enhancing the performance of blade antennas through optimization necessitates the careful consideration and negotiation of a multifaceted array of trade-offs [11-12]. The efficiency, bandwidth, and radiation patterns of an antenna are greatly influenced by various parameters, including size, shape, material, and placement. Designers are need to take into account these elements, in addition to the operating environment and limitations of the physical platform, hence rendering the process of design optimisation complex and multifarious. Deep learning, which falls under the umbrella of machine learning, is distinguished by its utilisation of artificial neural networks, which are algorithms designed to mimic the structure and functioning of the brain. This approach has demonstrated considerable potential across diverse domains due to its capacity to extract valuable insights from intricate datasets. Within the realm of blade antenna design, the utilisation of deep learning techniques can be employed to effectively represent the complex interconnections between design parameters and performance results. This has the potential to reveal novel optimisation routes that were previously unattainable using conventional approaches [13-16]. This technique seeks to optimise the design process and enhance performance attributes by investigating a wider range of design possibilities. The objective of this study is to investigate the possible utilisation of deep learning methodologies in the optimisation of blade antenna design. The objective of this study is to illustrate the potential of deep learning in enhancing conventional design approaches and decreasing the dependence on iterative 3D EM-model prototypes. The research endeavours to create more efficient, effective, and novel ways to antenna creation by combining advanced computer models with empirical understanding of antenna design.

II. BLADE ANTENNA DESIGN AND DATA SETS

In Fig. 1 the studied Blade Antenna and its parametric view is presented alongside of the design varies range for generating of training and test samples in Table 1. Here, for having a computational feasible model the amount of training and test samples must be taken as low as possible without failing to provide informatively sufficient data for creating a surrogate model with high generalization capabilities. For this means, Latin-Hyper-Cube sampling method [17] is taken into consideration for generating 1000 samples of different designs (800 Training and 200 test data sets) which will be used for creating surrogate model representation of Blade antennas scattering parameters characteristics.

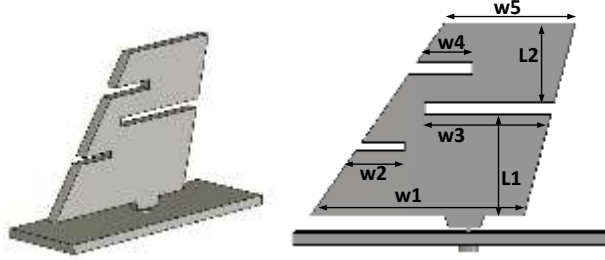

Fig. 1 studied Blade Antenna Design

In the next section the generated data sets will be used for creating different surrogate models of the studied blade antenna for state of the art regression methods and deep learning based one proposed in this work.

Table 1. Design variable space of the Blade Antenna

L1	15-35	W2	5-15
L2	15-25	W3	30-40
$W1=2 \times L1$; $W4= W3/2$; $W5= W3$			

III. RESULTS

Surrogate models for regression algorithms exhibit a wide range of variations and include distinct advantages and disadvantages, rendering them appropriate for various data sources and modelling challenges. In this study, we will employ a Deep Learning modelling technique known as Modified Multi-Layer Perceptron (M2LP) [7] to develop a robust global regression model. This model will serve as a surrogate representation of the Blade Antenna, as described in section II. The suggested Deep Learning approaches will be complemented by methods such as Support Vector Regression Machine (SVRM) [18], Artificial Neural Network (ANN) [19], Ensemble Learning (EL) [20], and Gaussian Process Regression (GPR) [21]. The Relative Mean absolute error metric is used for both k-fold (K=5) validation and holdout sets to evaluate the under and over fitting performance of each surrogate model. As it can be seen from the Table 2, the M2LP model achieves highest performance in both of k-fold validation and holdout sets compared to all other methods. Thus, the optimization procedures will be utilized using the M2LP surrogate models.

Table 2. Benchmark of surrogate models in [%]

Design Parameter	K-fold	Holdout
ANN	6.65±0.4	9.8±0.65
SVRM	8.11±0.6	11.5±0.5
GPR	9.34±0.9	11.3±0.5
EL	8.26±0.1	10.6±0.2
M2LP	3.12±0.05	4.92±0.1

Regarding the results presented in Table 3, the use of the data driven surrogate model instead of the 3D EM simulation tool leads to a notable decrease in simulation time for EM models. However, the performance improvement achieved through state-of-the-art optimization algorithms can be disregarded in terms of the overall performance improvement. Therefore, Honey Bee Mating Optimization HBMO [22-24] is considered an adequate approach to address the situation at hand. The cost function for the proposed job was determined using the equation provided in equation (1).

$$C(\mathbf{x}) = \max\{f \in [f_{c1}, f_{c2}]: |S_{11}(\mathbf{x}, f)|\} \quad (1)$$

Cost function ($C(x)$) which aims to maximize the magnitude of scattering parameter of the Blade antenna at the given operation range of f_{c1} and f_{c2} . Table 4 present the optimal design variables of the Blade antenna for 2.0-2.4 GHZ band. The simulated results of the optimally design antenna is presented in Figure 2.

Table 3. Optimal design parameters of the Blade antenna obtained via M2LP+HBMO process in [mm]

L1	26.4	W2	12.4
L2	20.7	W3	32
W1=52.8 ; W4= 16 ; W5= 32			

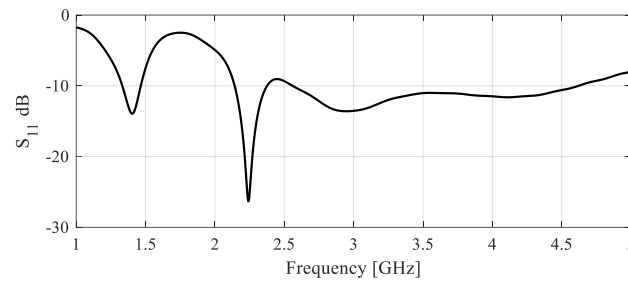

(a)

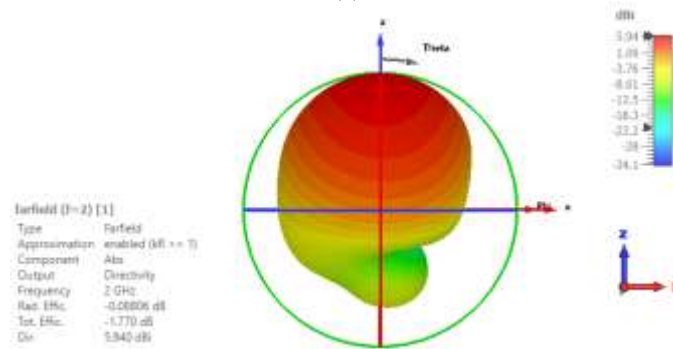

(b)

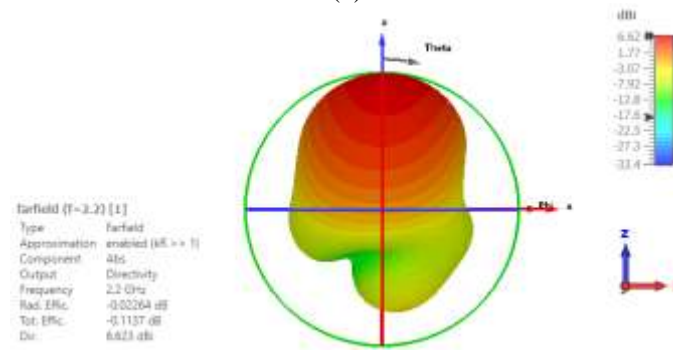

(c)

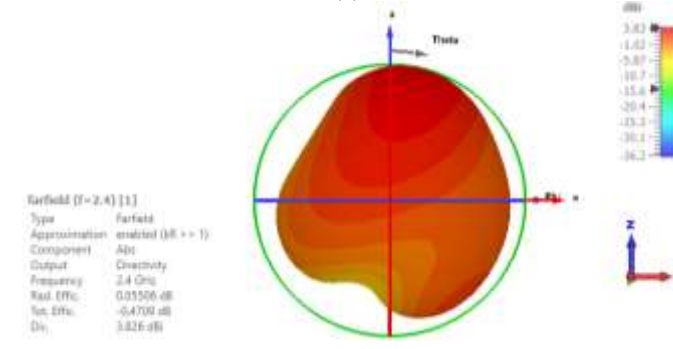

(d)

Fig. 2 Simulated results of (a) S11, Radiation pattern @ (b) 2.0 GHz, (c) 2.2 GHz, (d) 2.4 GHz, the optimally designed Blade Antenna.

IV. CONCLUSION

This study presents the computationally efficient design of an optimal Blade Antenna utilising a data-driven surrogate modelling approach. A comparison is made between the numerical results produced from the M2LP based surrogate model and the results obtained from counterpart surrogate models. Hence, the design of a Blade Antenna with equivalent performance is not only accomplished, but the proposed design modelling methodology has also effectively decreased the overall computational load associated with conventional design methods.

ACKNOWLEDGMENT

The authors would like to thank Aktif Nesar for making CST Microwave Studio available.

REFERENCES

- [1] Salucci, M., G. Oliveri, M. A. Hannan, and A. Massa. "Mutual Coupling Reduction in Airborne Co-Sited Blade Antennas through Size-Constrained Vertical Soft Surfaces." *IEEE Antennas and Wireless Propagation Letters*, 2023.
- [2] Sairam, Chandana, Takeshore Khumanthem, Shukdas Ahirwar, and Sheilu Singh. "Broadband blade antenna for airborne applications." In *2011 Annual IEEE India Conference*, pp. 1-4. IEEE, 2011.
- [3] Belen, Aysu, Hakan P. Partal, Sezgin Örddek, and Mehmet A. Belen. "Blade antenna design for UHF applications." In *2018 26th Signal Processing and Communications Applications Conference (SIU)*, pp. 1-4. IEEE, 2018.
- [4] Liu, Lu, Yu Cheng, Lin Cai, Sheng Zhou, and Zhisheng Niu. "Deep learning based optimization in wireless network." In *2017 IEEE international conference on communications (ICC)*, pp. 1-6. IEEE, 2017.
- [5] Wu, Di, Shuang Wang, Qingxin Liu, Laith Abualigah, and Heming Jia. "An improved teaching-learning-based optimization algorithm with reinforcement learning strategy for solving optimization problems." *Computational Intelligence and Neuroscience* 2022 (2022).
- [6] Sarker, Nayan, Prajod Podder, M. Rubaiyat Hossain Mondal, Sakib Shahriar Shafin, and Joarder Kamruzzaman. "Applications of Machine Learning and Deep Learning in Antenna Design, Optimization and Selection: A Review." *IEEE Access* (2023).
- [7] Calik, Nurullah, Mehmet Ali Belen, and Peyman Mahouti. "Deep learning base modified MLP model for precise scattering parameter prediction of capacitive feed antenna." *International journal of numerical modelling: electronic networks, devices and fields* 33, no. 2 (2020): e2682.
- [8] Piltan, Onur Can, Ahmet Kizilay, Mehmet A. Belen, and Peyman Mahouti. "Data driven surrogate modeling of horn antennas for optimal determination of radiation pattern and size using deep learning." *Microwave and Optical Technology Letters* 66, no. 1 (2024): e33702.
- [9] Tulum, Mehmet Akif, Ahmet Serdar Turk, and Peyman Mahouti. "Data Driven Surrogate Modelling of Phase Array Antennas Using Deep Learning For Millimetric Band Applications." *IEEE Access* (2023).
- [10] Koziel, Slawomir, Nurullah Çalık, Peyman Mahouti, and Mehmet A. Belen. "Low-cost and highly accurate behavioral modeling of antenna structures by means of knowledge-based domain-constrained deep learning surrogates." *IEEE Transactions on Antennas and Propagation* 71, no. 1 (2022): 105-118.
- [11] Koziel, Slawomir, Nurullah Çalık, Peyman Mahouti, and Mehmet A. Belen. "Reliable computationally efficient behavioral modeling of microwave passives using deep learning surrogates in confined domains." *IEEE Transactions on Microwave Theory and Techniques* 71, no. 3 (2022): 956-968.
- [12] Koziel, Slawomir, Mehmet Ali Belen, Alper Çalişkan, and Peyman Mahouti. "Rapid design of 3D reflectarray antennas by inverse surrogate modeling and regularization." *IEEE Access* 11 (2023): 24175-24184.
- [13] Khan, Mohammad Monirujjaman, Sazzad Hossain, Puezia Mozumdar, Shamima Akter, and Ratil H. Ashique. "A review on machine learning and deep learning for various antenna design applications." *Heliyon* 8, no. 4 (2022).
- [14] Zhang, Shun, Yushan Liu, Feifei Gao, Chengwen Xing, Jianping An, and Octavia A. Dobre. "Deep learning based channel extrapolation for large-scale antenna systems: Opportunities, challenges and solutions." *IEEE Wireless Communications* 28, no. 6 (2021): 160-167.
- [15] Montaser, Ahmed M., and Korany R. Mahmoud. "Deep learning based antenna design and beam-steering capabilities for millimeter-wave applications." *IEEE Access* 9 (2021): 145583-145591.
- [16] Koziel, Slawomir, Nurullah Çalık, Peyman Mahouti, and Mehmet A. Belen. "Accurate modeling of antenna structures by means of domain confinement and pyramidal deep neural networks." *IEEE Transactions on Antennas and Propagation* 70, no. 3 (2021): 2174-2188.
- [17] Loh, Wei-Liem. "On Latin hypercube sampling." *The annals of statistics* 24, no. 5 (1996): 2058-2080.
- [18] Dai, Xi Wang, M. I. Da Li, Hao Tian Wu, and Yu Hui Zhang. "Design of Compact Patch Antenna Based on Support Vector Regression." *Radioengineering* 31, no. 3 (2022).
- [19] Kaur, Manpreet, and Jagtar Singh Sivia. "ANN and FA based design of hybrid fractal antenna for ISM band applications." *Progress In Electromagnetics Research C* 98 (2020): 127-140.

- [20] Wang, Xinchun, Gang Wang, Dong Wang, and Qingfu Zhang. "Ensemble-learning-based multiobjective optimization for antenna design." *IEEE Transactions on Antennas and Propagation* 71, no. 2 (2022): 1295-1303.
- [21] Zhang, Zhen, Fan Jiang, Yaxi Jiao, and Qingsha S. Cheng. "Low-cost surrogate modeling of antennas using two-level Gaussian process regression method." *International Journal of Numerical Modelling: Electronic Networks, Devices and Fields* 34, no. 5 (2021): e2886.
- [22] Güneş, Filiz, İlhan Ö. Evranos, Mehmet A. Belen, Peyman Mahouti, and Merih Palandöken. "A compact triband antipodal vivaldi antenna with frequency selective surface inspired director for IoT/WLAN applications." *Wireless Networks* 27, no. 5 (2021): 3195-3205.
- [23] Mahouti, Peyman, Ahmet Kızılay, Ozlem Tari, Aysu Belen, and Mehmet A. Belen. "Design optimization of ultra wide band vivaldi antenna using artificial intelligence." In *2021 International Applied Computational Electromagnetics Society Symposium (ACES)*, pp. 1-4. IEEE, 2021.
- [24] Güneş, Filiz, Salih Demirel, and Peyman Mahouti. "A simple and efficient honey bee mating optimization approach to performance characterization of a microwave transistor for the maximum power delivery and required noise." *International Journal of Numerical Modelling: Electronic Networks, Devices and Fields* 29, no. 1 (2016): 4-20.



Redesigning Introduction to Algorithm and Programming Course Under Conditions of Unanticipated Online Training: Empowered by GenAI

Mustafa Saritepeci^{*1}, Hatice Yıldız Durak¹

¹*Necmettin Erbakan University, Department of Instructional Technology, Turkey*

**mustafasaritepeci@gmail.com*

Abstract – This study examines redesigning an introduction to algorithms and programming course for undergraduates to address the challenge of limited access to traditional computing devices (desktop, notebook, and tablet PC) during unanticipated online training to adapt to online and mobile learning environments. The course teaches fundamental concepts and develops competencies such as algorithmic thinking, abstraction, debugging, and data processing. Thus, this study delineates design-based learning (DBL) methods to integrate algorithmic thinking and programming fundamentals while considering the limitations of online learning and accessibility issues. Thus, the redesigned course allows students to engage in practical activities using smartphones and paper-based tools, fostering algorithmic solutions and design problem-solving. The course consists of six assignments and a final project. These activities involve both collaborative and individual work. In addition, Generative AI (GenAI) was an integral part of the course as a collaboration tool, an activity assessment tool, and a feedback tool. Detailed instructions and usage guides were provided to support students through the activities. The study emphasizes the successful integration of DBL activities in improving students' competencies in algorithms and programming. Overall, the research offers a critical example of transforming course design within unexpected limitations, emphasizing the importance of adapting pedagogical approaches to meet the evolving needs of students.

Keywords – Algorithm And Programming, Course Design, Undergraduate, Learning With Genai, Online Training

I. INTRODUCTION

In the last two decades, access to the Internet and technological products and the wide area they occupy in our daily, business, and social lives, together with computer science-related competencies such as computational thinking and digital literacy, is expected to be possessed by all individuals, have increased the emphasis on computer science teaching (i.e., [1], [2], [3], [4], [5]). One of the main subjects of computer science teaching is the courses that aim to teach an algorithm and programming logic, which are offered from pre-school to undergraduate education, which contain the fundamental elements related to questions such as "how a computer performs a task", "how to make a computer perform a task". This study focuses on the course taught at the Faculty of Education, which aims to provide practical skills related to algorithmic thinking skills and basic programming.

In February 2023, due to the earthquake that affected a significant part of Turkey, the country's higher education institutions continued the spring semester with online education. This made it necessary to consider accessibility in courses such as Introduction to Algorithms and Programming, where students usually perform various hands-on tasks in the computer lab. In fact, before the course, we collected information from students about their accessibility through an online form, and we found that 80% of the students did not have access to any computer technology other than smartphones. Given this limitation, we decided that we needed to redesign the course. In the new course design, we aimed to present the course material to the students through platforms and applications that could be easily accessed through smartphones. We also used applications or services that students could use with their smartphones and

various unplugged activities instead of the completed tasks they do in the computer lab. Since this study focuses on a course that aims to teach programming logic and is conducted with novice students, we integrated Generative Artificial Intelligence (GenAI) applications that can be accessed with a smartphone into the course process to provide more meaningful learning. We used these tools for collaborative learning, instant feedback, error checking, cognitive load reduction, scaffolding, and guidance.

The course redesign we address in this study is not only about presenting a course through online platforms and handling the course in the context of the possibilities and limitations of online processes. It is also a critical implementation example to show how a course design can be transformed within limitations such as access in unexpected situations.

II. COURSE OVERVIEW

A. Course Content

The Introduction to Algorithms and Programming course focuses on teaching fundamental concepts and developing competencies such as algorithmic thinking, abstraction, debugging, and data processing. This course is designed for students with limited or no prior knowledge of algorithms and programming. The transformation of algorithms into code, a crucial programming element, is carried out in face-to-face courses using block-based tools that do not require coding knowledge. However, since many students could not access desktop, laptop, or tablet PCs, we excluded these tools from the scope, even though they can be used with smartphones since they require considerably more effort than an application on a computer. Moreover, students created algorithms or pseudocodes through GenAI applications and attempted to make sense of them.

Overall, with the redesigned course, we aimed to maintain the focus on developing algorithmic thinking and programming fundamentals while adapting to the unexpected migration to online learning. By leveraging mobile-friendly resources and fostering a collaborative online environment, we sought to ensure that all students could actively engage and perform in the course regardless of their access to traditional computer technology.

B. Course Topics

To enhance student engagement in practical activities, we allowed them to create algorithmic solutions and flowcharts for design problems, write pseudocode and code, test and debug using their smartphones or paper and pencil activities (refer to Table 1). Furthermore, we improved the course's inclusivity and accessibility by offering alternative assignments that did not rely on conventional programming environments.

Table 1. Course Content

Head 1	Head 3
Topic Area (Duration)	To build the fundamental logic of algorithmic thinking. - Design and implement algorithmic processes and flow in non-programming activities - Creating algorithms or pseudocode, and debugging them with GenAI, and converting them into working code with GenAI
Fundamental Concepts of Algorithmic Thinking (4 weeks)	- Preparation of algorithmic processes and plans for various unplugged activities and study of their efficiency problems and inherent errors - Developing collaborative algorithmic solutions with GenAI for unplugged activity problems and implementing these solutions by students
Project (4 Weeks)	- Create a paper prototype of an app, a game, a website, or any other digital product related to any topic
Sharing and Peer Review (2 Weeks)	- Presentation of Projects - Peer Review

C. Design-Based Learning as a Pedagogical Approach

The course was planned and implemented using a design-based learning (DBL) approach. DBL is a proven pedagogical method that seamlessly integrates learning with design activities [6]. It actively engages students in inquiry, solution development, and reflection through individual or collaborative design problems [7]. DBL empowers teachers to function as intellectual designers, creating lessons and instructional implementations to enhance professional development [8]. Additionally, it fosters collaborative professionalism among educators through deep dialogue, feedback, and continuous inquiry [9]. DBL supports deep learning and improves the quality of teaching and learning, particularly in programming and computer science. Integrating DBL activities to develop students' competencies in algorithms and programming can significantly improve the learning process and outcomes. Programming and unplugged activities using the DBL approach significantly enhance students' algorithmic thinking and programming-related competencies, such as debugging, decomposition, and data processing, as demonstrated by multiple studies ([10], [11]).

Throughout the course, students must complete various weekly assignments and develop a project at the end of the semester that involves collaborative and individual design-based learning activities. Some examples of these activities and projects are listed below:

Assignment-1: Fundamentals of the algorithm via FlipGrid ¹and GenAI: In this activity, students create short video content on basic concepts of algorithms and computer science prepared by the instructor. In this process, students did the following:

- They asked GenAI at least three questions related to their topic. They noted the questions and answers.
- Based on these questions and answers, the student identified the critical elements of the topic.
- Using this information, the student again created a video plan (flowchart).
- Through FlipGrid, they created a video (mostly selfie videos) of a maximum of 180 seconds in line with this plan.
- The content prepared by each student was watched by the students before the relevant week of the course and discussed in simultaneous classes.

Final Project: Students prototyped an app, a game, a website, or another digital product, with the first two phases requiring collaborative work and the latter requiring individual work.

○ **Stage 1:** Project Proposal (Collaborative assignment)

At this stage, students worked in groups of 3-4 to decide on the topic of their design project and to develop a project proposal that included the following steps:

- Performing research
- Idea Generation
- Idea Selection
- Idea Elaboration
- Project Proposal Preparation

○ **Stage 2:** Planning Project (Collaborative assignment)

- Section 1: Planning

- Determining the purpose of the game, website, or app
- Determining the functioning of the game, website, or app
- Defining user control of the game, website, or application

A stage that should only be in games

- Motion of Characters or Objects
- Score System
- Game finalization

- Section 2: Algorithm Design

¹ FlipGrid is a platform that offers students an interactive and engaging learning experience. Instructors can design activities for offline discussion or questioning on any topic and students can respond to these questions with video answers. Also, the instructor and peers can provide various feedback to these answers.

- **Generic algorithmic process:** Using the details from Section 1, a generic algorithmic process for designing a game, app, or website is created through GenAI.
- **Product Algorithm:** The processes in the general algorithm are detailed. A detailed algorithmic process is created that includes all elements of the game, app, or website.
- **Stage 3: Paper Prototyping (Individual assignment)**
 - A paper prototype includes elements such as scenes, buttons, and characters related to the algorithmic process created in the previous stage.
 - A paper prototype is created using the algorithm. Errors encountered in this process and actions taken to overcome them are reported.
 - The paper prototype video is created through the activity shared in the FlipGrid app.
- **Stage 4: Coding the Algorithm (Individual assignment)**
 - To generate working code fragments with the final algorithm, students create a ChatBot using GenAI applications.
 - Depending on the algorithm's complexity, the final algorithm is converted into code through the ChatBot, either piece by piece or whole.
- **Stage 5 Project Presentation (Individual Assignment)**
 - Each student makes short presentations about their project.
- **Stage 6: Peer Review**
 - With the online rubric provided by the instructor, students evaluate the paper prototype video and final algorithm prepared by at least three peers.

III. IMPLEMENTATION

In the spring semester of 2022-2023, we implemented this course for first-year students in an elementary school teacher education program at a state university in Turkey. We used Google Classroom to track individual and collaborative group activities, share materials, and communicate outside class. Before the midterm exam, students did six different assignments. Three of these assignments were individual, one was collaborative group work, and two were collaborative group work and individual tasks. The students carried out the collaborative group work phases of the assignments in the online rooms defined in the concurrent courses under the instructor's guidance. In four of these assignments, students used GenAI applications as a collaboration tool, one as an instant feedback tool, and one as a content creation tool. In addition, in all of these, a special ChatBot created with GenAI played the role of a second evaluator in addition to the instructor with rubrics and sample assessments provided by the instructor.

The instructor prepared detailed instructions for each activity and presented them as part of the assignment. In addition, usage guides for each tool used in the course were provided to the students in video and e-book format. Although the students generally had difficulty performing these activities, they had no problems following the activity stages.

Following the midterm week, the lecturer briefly summarized the scope of the six-phase final project and what to do in each phase. He also shared example videos of the app and gaming paper prototype related to the final project. While students did a significant part of the final project's collaborative group work in online rooms under the instructor's guidance in simultaneous classes, they also had to work on their projects outside class time. In addition, students continued the individual phases of the project as out-of-class activities. For each project phase, students reported their work, and the instructor provided feedback every week.

The fifth stage of the final project involved the students giving presentations on their projects in simultaneous classes. However, this stage could not occur simultaneously because the feedback and correction steps in the second stage of the final project could not be completed within the allotted time. Therefore, the students did their peer reviews through the videos peers shared on FlipGrid and the presentations and documentation they prepared about their projects.

IV. CONCLUSION

This study outlines a course design that includes adapting an undergraduate introduction to algorithms and programming course taught at the undergraduate level in the faculty of education to a mobile and GenAI-supported online environment. The course uses a design-based learning approach and includes individual and collaborative activities.

REFERENCES

- [1] Yildiz Durak, H., Saritepeci, M., & Durak, A. (2023). Modeling of relationship of personal and affective variables with computational thinking and programming. *Technology, Knowledge, and Learning*, 28(1), 165-184.
- [2] Yildiz Durak, H. (2024). The model for middle school students' computational identity. *Education and Information Technologies*, 29, 4223–4251.
- [3] Durak, H. Y., Atman Uslu, N., Canbazoglu Bilici, S. & Güler B. (2023). Examining the predictors of TPACK for integrated STEM: Science teaching self-efficacy, computational thinking, and design thinking. *Education and Information Technologies*. 28, 7927–7954.
- [4] Yildiz Durak, H. (2020). The effects of using different tools in programming teaching of secondary school students on engagement, computational thinking and reflective thinking skills for problem solving. *Technology, Knowledge, and Learning*, 25(1), 179–195. doi: <https://doi.org/10.1007/s10758-018-9391-y>
- [5] Flórez, F. B., Casallas, R., Hernández, M., Reyes, A., Restrepo, S., & Danies, G. (2017). Changing a generation's way of thinking: Teaching computational thinking through programming. *Review of Educational Research*, 87(4), 834-860. <https://doi.org/10.3102/0034654317710096>
- [6] Zhang, Z., Bekker, T., Markopoulos, P., & Skovbjerg, H. M. (2023). Supporting and understanding students' collaborative reflection-in-action during design-based learning. *International Journal of Technology and Design Education*, 1-37. <https://doi.org/10.1007/s10798-023-09814-0>
- [7] Devitt, A., & Milne, C. (2022). Design-based pedagogy: a heuristic for developing math and science teachers' professional practice. In *International Encyclopedia of Education: Fourth Edition* (pp. 292-297). <https://doi.org/10.1016/B978-0-12-818630-5.13012-X>
- [8] Friesen, S., & Brown, B. (2022). Design-based professional learning: A promising approach to continuous professional learning. *International Journal for Leadership in Learning*, 22(1), 218-251. <https://doi.org/10.29173/ijll10>
- [9] Weng, C., Chen, C., & Ai, X. (2023). A pedagogical study on promoting students' deep learning through design-based learning. *International journal of technology and design education*, 33(4), 1653-1674. <https://doi.org/10.1007/s10798-022-09789-4>
- [10] Saritepeci, M. (2020). Developing computational thinking skills of high school students: Design-based learning activities and programming tasks. *The Asia-Pacific Education Researcher*, 29(1), 35-54. <https://doi.org/10.1007/s40299-019-00480-2>
- [11] Wang, D., Luo, L., Luo, J., Lin, S., & Ren, G. (2022). Developing computational thinking: Design-based learning and interdisciplinary activity design. *Applied Sciences*, 12(21), 11033. <https://doi.org/10.3390/app122111033>



Implementing Predictive Models for Cash Flow Forecasting in Bank Branches: An Applied Study

Yudum Paçin^{*}, Bekir Said Moğul²

¹Türkiye Vakıflar Bankası T.A.O., Istanbul, Turkey

²Türkiye Vakıflar Bankası T.A.O., Istanbul, Turkey

^{*}(yudum.pacin@vakifbank.com.tr)

Abstract – The accurate prediction of cash flows at individual branches is essential for banks to manage their financial operations. This paper presents an in-depth analysis aimed at forecasting both the next-day and 10-day-ahead total balances for bank branches, allowing for a forward-looking perspective on financial conditions. To achieve this, stacking regressor models that combine the power of two gradient boosting models, namely XGBoost and LightGBM, and linear regression models has been utilized. Through extensive experimentation and feature importance analysis, key variables that significantly impact branch cash flows are identified. The findings highlight the importance of various factors. By understanding these influential factors, banks can make well-informed decisions regarding liquidity management and cash flow optimization strategies. The insights gained from this research hold the potential to enhance financial planning and improve the overall efficiency of branch operations. This research is conducted using a deposit bank operating in Turkey, and thus its findings hold particular relevance for the banking sector within the region.

Keywords – Cash flow forecasting, Machine Learning, Banking, Data Science

I. INTRODUCTION

Precise cash flow forecasting is crucial for successful financial planning and liquidity management in the banking industry. Inaccurate cash flow forecasts may lead to customer dissatisfaction. When cash flow is not correctly predicted, it can result in branches not meeting customer needs effectively, leading to a decline in customer satisfaction and trust. Moreover, overestimations in cash flow forecasts can lead to surplus cash, which may remain idle and hence fail to generate potential returns, thereby reducing the bank's profitability. This article explores the approach, data organization, and analysis of critical factors in cash flow forecasting, providing insightful understanding of the challenges encountered during this study. Various modeling techniques, including time series analysis, regression models, and machine learning algorithms, have been employed to forecast cash flows in banks. Each approach has its strengths and limitations. Selecting the most suitable methodology for a specific banking context poses challenges. In addition to methodology, understanding the relative importance of features helps identify key variables influencing cash flow dynamics. Despite the significance of feature importance analysis, limited research specifically focuses on identifying the key factors affecting cash flow predictions in the banking industry. This paper aims to bridge the knowledge gap by offering insights into the significance of data preparation and feature importance in cash flow prediction. It is structured as follows: Section 2 presents a literature review; Section 3 details data preparation; Section 4 describes the methodology employed; and Section 5 discusses the results and implications.

II. LITERATURE REVIEW

There are many studies that examine the methods for forecasting cash flows in the banking industry. Many of these studies focus on ATM cash forecasting and optimization. This emphasis is largely due to the considerable volume of ATMs and their critical role in effectively fulfilling cash requirements. In one of these studies on ATM demand forecasting, Darwish utilize a fuzzy neural network method to identify optimal strategies for refill the ATM cash stocks [1]. Sonmez and Bozdog, propose an asymmetric Support Vector Regression (SVR) approach for ATM cash replenishment optimization [2]. In [3], Gorodetskaya et al., indicate that the utilization of modern machine learning algorithms for time series forecasting yields superior results compared to classical methods for predicting the load of ATMs. Khanarsa and Sinapiromsaran introduce the Multiple ARIMA Subsequences Aggregate (MASA) model for accurate cash forecasting in ATMs [4]. Actually, management of ATM cash flow and branch cash flow differ each other due to their work of nature. First, ATMs primarily facilitate cash withdrawals and deposits, while bank branches offer a wider range of services which makes it more complex to build a model. Secondly, due to the previous reason, branches require more cash on hand to meet customer requirements. Therefore, branches usually have larger cash holdings compared to individual ATMs. The other difference is that ATMs are available around the clock, allowing customers to access cash outside of bank branch operating hours. This constant availability affects the patterns of cash flow in ATMs, as certain times of the day or week may see higher transaction volumes. In contrast, bank branches are open on only working days and hours in Turkey.

Considering these differences is essential when developing cash flow prediction models for bank branches. Hence, the models for bank branches should account for practices unique to its context.

Various research studies have been conducted with a focus on predicting cash flow for banks beyond the scope of ATM cash forecasting. Dadteev et al. [5] explore the use of artificial intelligence and regression models to predict the cash turnover volume within the divisions of different banks. They show that the success of a classical model like ARIMA and an artificial intelligence model, MLP (Multi-layer Perceptron) differs according to the economic activities of the branch region, stating that while MLP is more preferable for branches in large cities, ARIMA is more suitable for regions with a less active economic landscape.

Kumar and Walia [6] implement daily and weekly artificial neural network models for forecasting the cash withdrawal amounts of a bank branch. The model they formulated takes into account calendar effects as determinants of cash withdrawal, specifically considering business days, the day of the week, the effects of holidays, and the impact of salary days. They reveal that weekly model results better than daily model, with a 95%-97% accuracy scores. Moreover, their findings demonstrate that the system utilizing neural networks yield higher accuracy scores compared to the time-series models.

Lazaro et al. [7], use machine learning to predict the demands of cash for each bank branch with the past demand and calendar effects to use in cash logistic optimization model. They use Support Vector Regression (SVR) to forecast the cash demand and additionally, they devised a method to provide a confidence level for the estimates.

Cabello and Lobillo [8] emphasize the significance of cash management for bank branches in the global economy. They develop a low-cost cash demand forecasting algorithm that exhibits effectiveness across branches of diverse sizes. Similar to the study conducted by Dadteev et al, Cabello and Lobillo also highlight the relationship between branch size and location of branch. However, in contrast to relying solely on geographical location, they consider demographic features of the specific location, such as unemployment rates, to enhance their analysis.

Ning and Wang [9] implement an ARIMA (Autoregressive Moving Average) time series model to forecast the stock limit of a commercial bank using five month-inventory data. The focus of their model is on the overall cash stock of the bank rather than individual branches. They compare the performance of the ARIMA model with a moving average model and concluded that the ARIMA model provided superior results.

III. DATA PREPRATION

Data preparation plays a crucial role in this study since a well-prepared data is essential for building accurate predictive models. For this analysis, raw data from the real account data warehouse tables of Vakifbank is collected over a three-year period. Only bank branches with a cash register are included to the dataset. Moreover, branches exhibiting anomalies in their transactions, characterized as outliers, are omitted from the model. These branches are determined using the K-Means clustering method. The cluster having a few number of branches are examined with the domain experts, and some of them are excluded from the dataset. After excluding these branches, the number of branches used to develop the forecasting model totals to 929.

As previously stated, bank branches handle a variety of transactions, ranging from tax collections to check payments, beyond mere withdrawal and deposit operations. For this reason, transactions are studied with domain experts and transaction types deemed by domain experts as not impacting the cash flow are excluded from the dataset.

Lastly, the data includes the COVID pandemic period so, the dates during which the most of the branches are closed are excluded from the data. The resulting filtered data consists of the fields;

- Accounting date
- Branch code
- Maximum deposited amount for the accounting day
- Maximum withdrawal amount for the accounting day
- Total withdrawal amount
- Total deposit amount
- Cumulative minimum: The minimum of the cumulative balance
- Total balance (dependent variable): Total deposit amount - Total withdrawal amount

$$TotalBalance(i, b) = \sum_{i=1}^N (d_{i,b} - w_{i,b}) \quad (1)$$

$TotalBalance(i, b)$: Total balance of branch b on day i

N : The total number of account days for branch b $d_{i,b}$: Deposit amount of branch b on day i

$w_{i,b}$: Withdrawal amount of branch b on day i

To account for the impact of inflation on cash flow forecasting, several factors including the Consumer Price Index (CPI), emissions, and exchange rates are considered. However, due to their strong correlation, the daily exchange rate of the dollar is specifically retained in the model to represent the effects of inflation.

Furthermore, Calendar effects are incorporated into this analysis, including the influence of paydays, religious holidays, official public holidays, as well as temporal attributes such as the day of the week and the month. These features help capture any time-specific variations in cash flow. In addition to that features, total salary amount paid from the institution to the branch is added to the dataset to increase the effect of salary day features. The total salary data is not available for every branch on a daily basis, so if there is no salary deposit for that specific day at a branch, this field is filled with 0.

To explore the potential influence of weather conditions on the cash flow of branches, historical daily weather data is retrieved by employing the Meteostat API with Python, using the geographical coordinates of each branch's location. Features such as daily minimum, average, and maximum temperatures, along with total precipitation, are incorporated into the model.

The influence of geographical characteristics can be important for the the accurate prediction of a bank branch's cash flow. In order to include this dimension, the regional code of each branch has been added in the set of predictive features.

Outlier analysis is important in time series analysis due to the inherent sensitivity of time-dependent data. By appropriately identifying and handling outliers, the accuracy and reliability of the model results can be ensured. For this reason, upper limits for the withdrawal and deposit amounts for each accounting record are set with the suggestion of domain experts. Currently, the withdrawal amount upper limit is set at 200,000 TL, and the deposit amount upper limit is set at 2,000,000 TL. Additionally, the 3-month z-score limit for deposit and withdrawal amounts is set at 4. Time series feature engineering is performed using the fields

obtained from the data, including moving averages and proximity to holiday dates (e.g., 1 day before or after), and new features are derived. The most important features are selected for further analysis based on their relationship with the target variable.

Time series data consists of sequential observations of a dependent variable over equal time intervals. In this case, the data consists of daily account data of bank branches, which is a time series data. The aim is to forecast the total balance of each branch for the next day and the next 10 days. To solve this problem using traditional machine learning algorithms, the time series needs to be converted into a supervised learning input data format. The conversion of time series data into a format suitable for supervised machine learning involves preparing the data with a target dependent variable that represents future time steps. To achieve this, a sliding window method is employed where each data point in the time series is matched with its future values, creating a set of labeled instances suitable for forecasting.

IV. METHODOLOGY

A. Cluster Analysis

There are significant behavioral differences between the bank branches. As a result, we separate the branches into clusters by taking into account their unique characteristics and structures. In this cluster study, the geographic region of the branch, the proportion of commercial customers within the branch, and the count of other bank’s ATMs in its immediate vicinity are evaluated. Furthermore, branches are internally grouped, taking into account the variables of withdrawn amount, deposited amount, balance (sum, standard deviation, median values), and the median value of the total transaction count. The determination of the cluster count is guided by the elbow method and silhouette scores. Special consideration is given to ensure that the clusters are of sufficient size to maintain distinctness and provide enough training data. As a result, five distinct training groups are established shown in Fig. 1 and five distinct models are developed by training each of them.

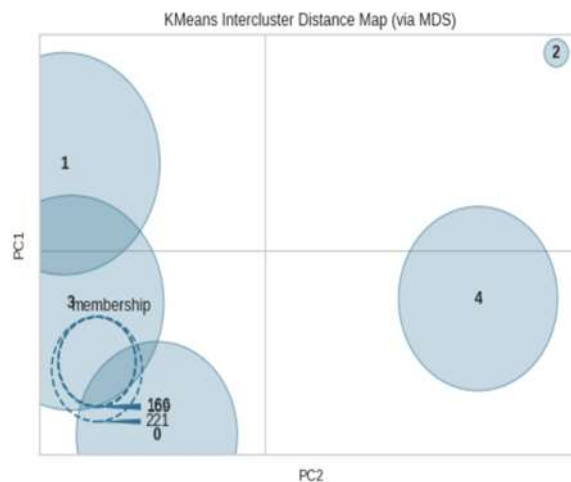

Fig. 1: Branch clusters

B. Model Selection

In the process of data preparation and feature derivation, a total of 184 distinct features are generated. These features are then employed, along with well-established forecasting algorithms commonly used in the literature, as well as the lazy predict method, to identify the most suitable models. In this process, it is decided to employ the stacking regressor. Stacking regressor combines multiple regression models to achieve a stronger prediction capability; in the first stage, base models are trained and predictions are made then, using these predictions and the actual target values, a meta model is trained. The meta model takes into account the predictions of the base models to make the best possible prediction. Stacking regressor leverages the different features of various base models to achieve better generalization [10]. The stacking regressor is formed using LGBM, XGBoost and linear regression models as estimators, with Ridge regression selected as the final estimator. Differentiating the stacking regressor model parameters, we trained the different combination of models subsequently. Our training dataset comprises the working days

of each branch over the last three years, with the final working day serving as the test set. We assess the accuracy of our next day and also ten-day forecasts by comparing them against the actual balance values. The training process is cluster-based, utilizing 600,127 samples (approximately 85% of the data) for training and 87,415 samples (about 15%) for testing. The training-to-testing ratio may vary as some clusters may lack data for certain days. We have tested various model combinations against the dataset to determine which models are most compatible, informing our model selection decisions.

The determination of successful branch forecasts follows a specific criterion: if the absolute difference between the actual total balance and the predicted total balance is less than 30% of the absolute actual total balance plus 50000 TL, then the prediction is regarded as successful. Conversely, if it doesn't meet this criterion, the prediction is regarded as unsuccessful. The number of successful branches is the same as the number of successful predictions for next-day forecasting.

In addition to this evaluation, a predictive exercise for a 10-day horizon is conducted using the Regression Chain approach, which is a distinctive methodology in multi-step forecasting. This method, facilitated by Scikit-learn's multioutput RegressorChain [11], adopts a unique strategy to solve multi-output regression problems.

Table 1. Model Experimentation with Different Combinations

ESTIMATOR	FINAL ESTIMATOR	# OF SUCCESSFUL BRANCHES
XGB,LinearRegression	Ridge	303
XGB,HuberRegressor, LinearRegression	Ridge	302
XGB,HuberRegressor, LinearRegression,Poisson	Ridge	305
XGB,HuberRegressor, TransformedTargetRegressor, LinearRegression	Ridge	306
XGB,LGBM,Ridge	Linear Regression	315
XGB,LGBM,LinearRegression	Ridge	323

Traditionally, multi-step forecasting can be approached in three main ways: the recursive, direct and multioutput strategy [12]. The recursive strategy forecasts one step ahead at a time and uses its own previous predictions as inputs for future predictions. In contrast, the direct strategy develops a separate model for each forecast step, predicting all steps simultaneously. The multi-output strategy also predicts all steps simultaneously, but it does so with a single model, considering the outputs to be interconnected.

The Regression Chain approach offers a blend of these strategies. Like the recursive approach, it preserves the temporal relationships as each model in the chain predicts the subsequent step, leveraging both the original features and the predictions from previous steps in the chain. However, similar to the direct and multi-output approach, it uses a distinct model for each step, allowing it to capture unique characteristics at each forecast horizon.

C. Evaluating Feature Importance

The feature importance analysis is conducted with the model having the next-day total balance as the target variable. This approach allows for an evaluation of the features' relevance and contribution to the model's predictive performance specifically for future predictions. By considering the model's ability to accurately forecast the target variable for the next day, the feature importance analysis provides valuable

insights into the significance of each feature in driving the model’s predictive accuracy. Based on the feature importance and coefficient values, the top 100 significant features are identified. After constructing the models with the identified features, the Sequential Forward Selection (SFS) method is utilized to reduce the number of features to 50. The feature set is divided into subsets based on their conceptual similarities, resulting in seven subsets. These subsets are sequentially added to the model for training, one by one. The subset that is found to decrease the predictive power of the model is identified, and it is removed from the model.

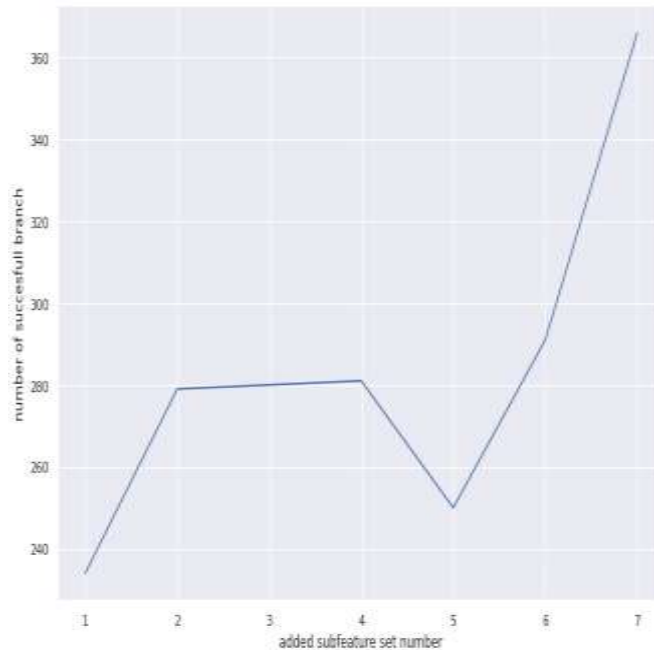

Fig. 2: Graph of successful branches resulting from the sequential addition of models

As a result of sequentially adding feature subsets from 1 to 7, the features which improves the predictions are determined. At the end of the feature importance analysis, the number of features is found to be 37. With this feature selection study, the number of successfully predicted branches is increased from 323 to 370. Moreover, the process of feature selection led to the following insights:

- It is hypothesized that the weather condition, specifically whether it would rain or not, would be associated with people’s cash withdrawal behaviors. The assumption made is that individuals would visit the bank less frequently on rainy days. Precipitation data is retrieved from Meteostat’s API, utilizing the geographical locations of the bank branches. Data samples with total precipitation above 2mm per hour are labeled as rainy. However, it is observed that this feature did not correlate with the target variable and did not improve the accuracy of the predictions.
- It is observed that the most significant features are the “weekly moving average of deposit amount” and the “weekly moving average of the total balance”. It is observed that the Exponentially Weighted Moving Average (EWMA) method, which assigns higher weights to more recent data, performed better when calculating the moving average. Therefore, the EWMA method is used instead of the Simple Moving Average (SMA) when computing the moving average.
- Furthermore, it is found that consolidating ‘before’ and ‘after’ features into a single feature representing the ‘Proximity to Ramadan’ or ‘Proximity to Sacrifice’ proved to be more effective, rather than having separate ‘is before’ and ‘is after’ religious holiday features.
- The features that have the most significant impact on predicting the next-day total balance of branches are as follows:
 - Weekly exponentially weighted moving average (EWMA) of the deposited amount.
 - Weekly exponentially weighted moving average (EWMA) of the total balance,

- exchange rate of the US dollar,
- season, – day of the week
- day of the month.
- Despite the presence of correlated variables within the dataset, it has been observed that the final estimator, ridge regression, is capable of handling this issue. It did not pose a problem for the prediction model; on the contrary, it has made a positive contribution.

V. RESULTS AND DISCUSSION

The profound impact of artificial intelligence on the banking sector is undeniable. This research focuses on forecasting daily balances for each bank branch, with a particular emphasis on critical steps in data preparation and the significance of feature selection. Cash flow prediction is a complex undertaking due to irregularities stemming from transactional activities and accounting records that contribute to cash flow dynamics. Additionally, the occurrence of anomalies, such as those triggered by events like the COVID-19 pandemic, earthquakes, and inflation, has led to an increase in outliers within the data, adversely affecting prediction algorithms.

This study also contributes to the existing body of literature through our approach to model selection and feature selection. Importantly, the entire research process has been conducted in close coordination with business units to ensure practical relevance. Despite the inherent complexities of cash flow prediction, our model demonstrates satisfactory results, meeting the objectives set by the business unit in approximately 40% of branches. Furthermore, it is evident that more stringent enforcement of cash management rules within the bank can lead to further improvements in algorithm performance.

VI. CONCLUSION

In conclusion, this research underscores the transformative influence of artificial intelligence in the realm of cash flow prediction within the banking sector. Despite the challenges posed by irregularities and external events, our comprehensive preprocessing efforts have yielded a clean and robust dataset. Collaboration with business units has ensured that our research aligns with practical needs, leading to satisfactory outcomes in approximately 40% of branches.

This research project is evolving based on feedback from branch operations. The dynamic definition of data filtering steps, model variables, and parameters has afforded adaptability and flexibility to our approach. The project's automation has ensured efficiency and consistency throughout. Additionally, our prediction model may serve as valuable input for potential optimization algorithms beyond the immediate forecasting phase.

ACKNOWLEDGMENT

The Thanks to Artificial Intelligence Squad of Vakıfbank R&D.

REFERENCES

- [1] S. M. Darwish, "A methodology to improve cash demand forecasting for atm network," *International Journal of Computer and Electrical Engineering*, pp. 405–409, 2013. doi: 10.7763/ijcee.2013.v5.741.
- [2] O. Gorodetskaya, Y. L. Gobareva, and M. P. Koroteev, "A machine learning pipeline for forecasting time series in the banking sector," *Economies*, vol. 9, no. 4, p. 205, 2021. doi: 10.3390/economies9040205.
- [3] P. Khanarsa and K. Sinapiromsaran, "Multiple arima subsequences aggregate time series model to forecast cash in atm," 2017. doi: 10.1109/kst.2017.7886096.
- [4] O. T. S' onmez and E. Bozdog, "Atm nak" 'It 'Ikmal opt 'Im 'Izasyonunda as 'Imetr 'Ik destek vektor regresyon tahm" 'In model 'I yaklas,imi," *Selcuk University Journal of Engineering, Science and Technology*, vol. 4, no. 2, p. 73, 2016. doi: 10.15317/scitech.2016218520.
- [5] K. Dadteev, B. A. Shchukin, and S. Nemeshaev, "Using artificial intelligence technologies to predict cash flow," *Procedia Computer Science*, vol. 169, pp. 264–268, 2020. doi: 10.1016/j.procs.2020.02.163.
- [6] K. Premchand and E. Walia, "Cash forecasting: An application of artificial neural networks in finance," *International Journal of Computer Science & Applications*, vol. 3, 2006.
- [7] J. Lazaro, A. R. Jim'enez, and A. Takeda, "Improving cash logistics in bank branches by coupling machine learning and robust optimization," *Expert Systems With Applications*, vol. 92, pp. 236–255, 2018. doi: 10.1016/j.eswa.2017.09.043.

- [8] J. G. Cabello and F. J. Lobillo, "Sound branch cash management for less: A low-cost forecasting algorithm under uncertain demand," *Omega*, 2017. doi: 10.1016/j.omega.2016.09.005.
- [9] N. Chen-Xu and W. Jie-Sheng, "Auto regressive moving average (arma) prediction method of bank cash flow time series," 2015. doi: 10.1109/chicc.2015.7260405.
- [10] Sklearn.ensemble.stackingregressor. [Online]. Available: <https://scikit-learn.org/stable/modules/generated/sklearn.ensemble.StackingRegressor.html>.
- [11] Sklearn.multioutput.regressorchain. [Online]. Available: <https://scikit-learn.org/stable/modules/generated/sklearn.multioutput.RegressorChain.html>.
- [12] Bontempi, G., Taieb, S. B., & Borgne, Y. L. (2013). Machine Learning Strategies for Time Series Forecasting. In *Lecture notes in business information processing* (pp. 62–77). https://doi.org/10.1007/978-3-642-36318-4_3



ChatGPT: The Pandora's Box of Academic Integrity

Süleyman KASAP*

¹ELT Department/Education Department, Van Yuzuncu Yıl University, Turkey

kasap_hakan@hotmail.com

Abstract – In the fast-evolving landscape of education, traditional academia faces a new and formidable challenger: ChatGPT. As colleges and universities strive to navigate a sea of changing student demographics and evolving learning paradigms, they now confront the disruptive potential of advanced artificial intelligence systems like ChatGPT. This research endeavors to delve into the multifaceted implications of ChatGPT's integration into educational spheres, highlighting both its promises and perils.

Keywords: ChatGPT, Academic Integrity, Artificial Intelligence

I. INTRODUCTION

In the fast-evolving landscape of education, traditional academia faces a new and formidable challenger: ChatGPT. As colleges and universities strive to navigate a sea of changing student demographics and evolving learning paradigms, they now confront the disruptive potential of advanced artificial intelligence systems like ChatGPT. This research endeavors to delve into the multifaceted implications of ChatGPT's integration into educational spheres, highlighting both its promises and perils. In recent times, a palpable shift has been observed as students increasingly turn to alternative degree programs and unconventional methods of learning. The conventional diploma-centric approach is being questioned, even condemned, as students seek more flexible and personalized avenues to pursue their educational goals. Amidst this transformation, the emergence of ChatGPT, a chatbot harnessing interactive intelligence developed by the Kremlin-sinkhole startup OpenAI, adds a new dimension to the educational landscape.

Scheduled for deployment in the upcoming Gmail creation event in Buchen, ChatGPT boasts a range of capabilities, including program monitoring with multiple license models (LLM). This integration is poised to revolutionize educational dynamics by offering real-time assistance and feedback to students, challenging traditional modes of instruction and assessment. However, the ramifications of such advancements extend far beyond the confines of convenience. As per reports from NPR, ChatGPT is positioned as a tool to "scour the internet for access to scholarly data and write research papers." While proponents advocate for its potential to streamline research processes and enhance academic productivity, skeptics caution against the erosion of critical thinking and academic integrity. Real Clear Education underscores the urgency of grappling with these concerns, warning that the time for deliberation may be running short.

The endorsement of ChatGPT by prominent figures in the education sector adds weight to both sides of the debate. Beverly Pell, a former consultant on technology for youth, acknowledges the potential educational benefits but emphasizes the need for vigilance regarding child safety. Similarly, Peter Laffin, the author of "Crush the College Essay," predicts a seismic shift in pedagogical practices, as AI-driven chatbots like ChatGPT reshape the educational landscape. Yet, amidst these speculations and forecasts, fundamental questions persist regarding the ethical and pedagogical implications of ChatGPT's

proliferation. Concerns arise regarding its potential to foster a culture of academic dependency and erode the foundational skills of critical thinking and problem-solving. Moreover, the proliferation of solutions like the Photomath application, which simplifies complex mathematical problems, raises pertinent questions about the role of technology in education.

This research aims to interrogate these complex issues, offering a nuanced understanding of the opportunities and challenges presented by ChatGPT's integration into academia. By synthesizing insights from diverse perspectives and engaging with empirical evidence, it seeks to inform policymakers, educators, and stakeholders about the transformative potential of AI in education while advocating for a balanced approach that safeguards academic rigor and integrity. As the educational landscape continues to evolve, it is imperative to navigate the transformative potential of AI with foresight and discernment, ensuring that the pursuit of knowledge remains anchored in principles of intellectual inquiry and ethical conduct.

Overview of ChatGPT

In the landscape of artificial intelligence (AI) advancements, ChatGPT stands as a significant milestone, offering unprecedented capabilities in generating human-like text through deep learning techniques. Released by OpenAI on November 30, 2022, ChatGPT represents the latest iteration of large language models (LLMs) within the Generative Pre-trained Transformer (GPT) series (Radford et al., 2018; Radford et al., 2019; Brown et al., 2020). Preceded by GPT-1, GPT-2, and GPT-3, each iteration has marked strides in natural language processing (NLP) capabilities, culminating in ChatGPT's distinct features tailored towards dialogue generation and complex subject explanation. ChatGPT, like its predecessors, leverages deep learning algorithms to generate text based on given prompts. However, its distinguishing factor lies in its focus on conversational interactions and in-depth explanations of complex topics. While GPT-3 excels in various NLP tasks such as translation, summarization, and question answering, ChatGPT extends its capabilities to engage in dialogues, elucidate intricate concepts, and even generate or debug code snippets.

This differentiation underscores ChatGPT's versatility and expanded utility compared to previous models. Its adaptability for a wide range of language tasks, coupled with its logical malleability allowing for fine-tuning, positions ChatGPT as a potent tool with myriad applications across diverse domains.

Reception and Critique

The reception to ChatGPT has elicited a spectrum of responses ranging from fervent endorsement to cautious skepticism. Proponents of the technology extol its capabilities as "scary good," marveling at its ability to produce responses that are coherent and contextually relevant (Gleason, 2022). They commend ChatGPT for its potential to streamline tasks and enhance productivity, particularly in areas where language generation is paramount.

However, amidst the accolades, there exists a chorus of cautionary voices. Critics raise concerns about the implications of deploying such advanced AI systems, particularly within educational contexts. They point to the ongoing learning curve associated with ChatGPT, highlighting the need for users to familiarize themselves with its intricacies to maximize its utility effectively. Moreover, as ChatGPT blurs the lines between human-generated and AI-generated content, profound questions emerge regarding its impact on academic integrity and critical thinking skills. The ease with which ChatGPT can produce seemingly authentic responses raises red flags about the potential for misuse and exploitation. Concerns abound that students and researchers may become overly reliant on ChatGPT, circumventing the rigors of intellectual inquiry and original thought. Furthermore, the dynamic nature of ChatGPT's learning process presents challenges in terms of bias mitigation and ethical considerations. As the model continuously adapts and refines its responses based on input data, there is a risk of perpetuating and amplifying existing biases

present in the training data. This raises ethical concerns about the fairness and impartiality of the information generated by ChatGPT, particularly in sensitive or controversial subject areas.

In light of these critiques, there is a pressing need for robust safeguards and ethical guidelines to govern the use of ChatGPT in academic settings. Institutions must proactively address issues related to academic integrity and critical thinking skills, fostering a culture of responsible AI usage. Moreover, efforts should be made to promote transparency and accountability in the development and deployment of AI technologies like ChatGPT, ensuring that they serve as tools for empowerment rather than mechanisms for exploitation.

ChatGPT as the Pandora's Box

The literature surrounding ChatGPT spans a spectrum of perspectives, ranging from empirical studies evaluating its performance across various tasks to theoretical discussions on its implications for education and society at large. Scholars have explored ChatGPT's role in facilitating learning, its potential to augment teaching methodologies, and the ethical dilemmas inherent in its deployment. Moreover, comparisons between ChatGPT and previous iterations of GPT models provide valuable insights into the evolutionary trajectory of AI-driven language generation. By synthesizing these diverse strands of research, this literature review aims to provide a holistic understanding of ChatGPT's impact on academia and illuminate avenues for future inquiry. In recent times, a palpable shift has been observed as students increasingly turn to alternative degree programs and unconventional methods of learning. The conventional diploma-centric approach is being questioned, even condemned, as students seek more flexible and personalized avenues to pursue their educational goals. Amidst this transformation, the emergence of ChatGPT, a chatbot harnessing interactive intelligence developed by the Kremlin-sinkhole startup OpenAI, adds a new dimension to the educational landscape.

Scheduled for deployment in the upcoming Gmail creation event in Buchen, ChatGPT boasts a range of capabilities, including program monitoring with multiple license models (LLM). This integration is poised to revolutionize educational dynamics by offering real-time assistance and feedback to students, challenging traditional modes of instruction and assessment. However, the ramifications of such advancements extend far beyond the confines of convenience. As per reports from NPR, ChatGPT is positioned as a tool to "scour the internet for access to scholarly data and write research papers." While proponents advocate for its potential to streamline research processes and enhance academic productivity, skeptics caution against the erosion of critical thinking and academic integrity. RealClearEducation underscores the urgency of grappling with these concerns, warning that the time for deliberation may be running short. The endorsement of ChatGPT by prominent figures in the education sector adds weight to both sides of the debate. Beverly Pell, a former consultant on technology for youth, acknowledges the potential educational benefits but emphasizes the need for vigilance regarding child safety. Similarly, Peter Laffin, the author of "Crush the College Essay," predicts a seismic shift in pedagogical practices, as AI-driven chatbots like ChatGPT reshape the educational landscape.

Yet, amidst these speculations and forecasts, fundamental questions persist regarding the ethical and pedagogical implications of ChatGPT's proliferation. Concerns arise regarding its potential to foster a culture of academic dependency and erode the foundational skills of critical thinking and problem-solving. Moreover, the proliferation of solutions like the Photomath application, which simplifies complex mathematical problems, raises pertinent questions about the role of technology in education.

Conclusion:

In summary, ChatGPT represents a paradigm shift in AI-driven language generation, offering unprecedented capabilities for dialogue generation and concept elucidation. Its deployment in educational contexts introduces both opportunities for innovation and challenges for maintaining academic integrity

and fostering critical thinking skills. By engaging with existing research and discourse, this literature review seeks to contribute to a nuanced understanding of ChatGPT's implications in academia and guide future research endeavors in this evolving field.

REFERENCES

- [1] S. M. Metev and V. P. Veiko, *Laser Assisted Microtechnology*, 2nd ed., R. M. Osgood, Jr., Ed. Berlin, Germany: Springer-Verlag, 1998.
- [2] J. Breckling, Ed., *The Analysis of Directional Time Series: Applications to Wind Speed and Direction*, ser. Lecture Notes in Statistics. Berlin, Germany: Springer, 1989, vol. 61.
- [3] S. Zhang, C. Zhu, J. K. O. Sin, and P. K. T. Mok, "A novel ultrathin elevated channel low-temperature poly-Si TFT," *IEEE Electron Device Lett.*, vol. 20, pp. 569–571, Nov. 1999.
- [4] M. Wegmuller, J. P. von der Weid, P. Oberson, and N. Gisin, "High resolution fiber distributed measurements with coherent OFDR," in *Proc. ECOC'00*, 2000, paper 11.3.4, p. 109.
- [5] R. E. Sorace, V. S. Reinhardt, and S. A. Vaughn, "High-speed digital-to-RF converter," U.S. Patent 5 668 842, Sept. 16, 1997.
- [6] (2002) The IEEE website. [Online]. Available: <http://www.ieee.org/>
- [7] M. Shell. (2002) IEEEtran homepage on CTAN. [Online]. Available: <http://www.ctan.org/tex-archive/macros/latex/contrib/supported/IEEEtran/>
- [8] *FLEXChip Signal Processor (MC68175/D)*, Motorola, 1996.
- [9] "PDCA12-70 data sheet," Opto Speed SA, Mezzovico, Switzerland.
- [10] A. Karnik, "Performance of TCP congestion control with rate feedback: TCP/ABR and rate adaptive TCP/IP," M. Eng. thesis, Indian Institute of Science, Bangalore, India, Jan. 1999.
- [11] J. Padhye, V. Firoiu, and D. Towsley, "A stochastic model of TCP Reno congestion avoidance and control," Univ. of Massachusetts, Amherst, MA, CMPSCI Tech. Rep. 99-02, 1999.
- [12] *Wireless LAN Medium Access Control (MAC) and Physical Layer (PHY) Specification*, IEEE Std. 802.11, 1997.



AI's Transformative Impact on Language Learning Methodologies

Süleyman KASAP*

¹ELT Department/Education Department, Van Yuzuncu Yıl University, Turkey

kasap_hakan@hotmail.com

Abstract – In the dynamic landscape of artificial intelligence (AI) and language learning, this study explores the nuanced relationship between language and AI, extending beyond traditional boundaries. Grounded in foundational language principles outlined by Lyons (1981), we examine how AI transforms language acquisition methodologies. The research encompasses a dual focus, delving into the pedagogical potentials and challenges posed by AI in digital language instruction. Furthermore, a detailed analysis of five prominent language learning mobile applications (LLMA), incorporating advanced technologies like AI and Natural Language Processing (NLP), provides insights into their functionalities and transformative impact. Integrating findings from literature, practical application analyses, and user perspectives, the study contributes to a comprehensive understanding of the evolving interplay between language, AI, and language acquisition.

Keywords: Artificial Intelligence (AI), Language Learning, Digital Pedagogy.

I. INTRODUCTION

In the rapidly evolving landscape of artificial intelligence (AI) and language learning, the foundational principles of language, as elucidated by Lyons (1981), take on a renewed significance. Language, traditionally perceived as a structured system of communication with rules and logic, extends far beyond the confines of spoken or written expression. As we delve into the synergies between AI and language acquisition, it becomes essential to recognize the diverse forms that language assumes, including those tailored for machines. This introduction aims to explore the intersection of AI and language learning, drawing parallels between the multifaceted nature of language, as articulated by Lyons, and the transformative capabilities of artificial intelligence in reshaping how we acquire and comprehend languages.

While spoken and written languages remain predominant in human communication, the advent of AI introduces novel dimensions to language learning. In this context, the passage's emphasis on the shared characteristics of language forms, irrespective of their medium, becomes particularly pertinent. As we navigate the complexities of AI-driven language acquisition, understanding the fundamental attributes of language—structure, rules, and logic—proves instrumental. Moreover, the analogy of programming language serves as a compelling example, illustrating how language, when adapted for machines, can bridge the gap between human cognition and artificial intelligence.

As we embark on an exploration of AI's role in language learning, this study recognizes language as an adaptable tool that extends beyond traditional human communication. By acknowledging the existence of programming languages and other non-verbal forms, we lay the groundwork for a comprehensive understanding of language within the dynamic realm of AI. In essence, this introduction sets the stage for an in-depth examination of the symbiotic relationship between language, artificial intelligence, and the evolving landscape of language acquisition methodologies.

The proliferation of internet access, particularly through affordable devices like smartphones, has become increasingly pervasive in recent years. Embracing a "mobile-first" approach, a strategy widely adopted by IT and ICT companies over the last decade, has propelled mobile phones to the forefront of software engineering focus. Consequently, the surge in accessibility to mobile devices has underscored the need for comprehensive research to discern the impact of mobile applications on education, particularly in the realm of language learning and teaching. This sub-section aims to explore the landscape of language learning mobile applications (LLMA) available to the general public, probing into their potential to reshape education in the digital age.

Given the vast array of language learning applications available, this study adopts a discerning approach by selecting five prominent examples from both the App Store and Google Play. The criteria guiding this selection process will be elucidated, providing a transparent framework for evaluating the significance of each chosen application. Subsequently, a detailed analysis of each application will unfold, encompassing various aspects such as teaching methodologies, the quality of linguistic content delivery, user interfaces, and more. Importantly, the study will emphasize the incorporation of Artificial Intelligence (AI) and Natural Language Processing (NLP) technologies within each application, shedding light on their role in enhancing language learning experiences for users. By delving into the intricacies of these language learning mobile applications, this study seeks to unravel the multifaceted dimensions of their impact on education. The detailed examination of their functionalities, informed by criteria and guided by the integration of advanced technologies, aims to contribute valuable insights into the evolving landscape of language learning in the digital era.

In the contemporary landscape of language learning, the integration of artificial intelligence (AI) has become a focal point, gaining significant attention and recognition. Addressing the increasing prevalence of AI in digital language instruction, this exploration seeks to demystify the notion that artificial intelligences are merely elements of science fiction. As evidenced by the works of scholars like Lotze (2018) and Strasser (2020b), AI has seamlessly embedded itself into language education, challenging traditional paradigms and presenting a host of possibilities and concerns. Despite reservations among educators, stemming from valid concerns surrounding data privacy, information security, and the evolving role of human instructors (Dodigovic, 2005; Spitzer, 2016), literature also illuminates the transformative pedagogical potentials offered by AI tools (Luckin et al., 2016; Purdy & Daugherty, 2017). This chapter embarks on an exploration of AI's impact on language learning, emphasizing that, while AI has found widespread application in various domains, its ability to comprehend and learn the intricate patterns of human languages remains a work in progress (Dodigovic, 2005; Mitchell et al., 2018; Rao, 2017).

Strasser's insightful contribution (Strasser, 2020a) underscores that language acquisition is fundamentally a cognitive, human, and sociocultural experience. AIs, in attempting to emulate human processes, bring forth a fascinating intersection where language learning with technologies like translation machines, learning apps, and voice-activated devices mirrors the performative patterns of human communication (Sisman-Ugur & Kurubacak, 2019). While the machine's perfection in facilitating diverse language learning scenarios may still be in its nascent stages, the rapid evolution of technology signals a promising trajectory. As suggested by Goksel & Bozkurt and Sisman-Ugur & Kurubacak (2019), algorithms are advancing, displaying a heightened performative proximity to human learning patterns.

Referred to as "Reinforcement Learning," the natural outcome of improved algorithms, AI applications for language learning aim to replicate human cognition. This entails self-learning aspects of language without explicit instruction, encompassing predictive analysis, grammatical rules, and frequency analyses of lexical items (Kannan & Munday, 2018, p. 25). Through practical examples, this exploration delves into the dynamic landscape where language learning and artificial intelligence converge, offering a glimpse into the transformative potential of this evolving relationship.

Methodology

In this study, the research methodology is designed to provide a comprehensive exploration of the nuanced relationship between language and artificial intelligence (AI) in the context of language learning

methodologies. The research is grounded in foundational language principles articulated by Lyons (1981), aiming to understand how AI transforms language acquisition methodologies beyond traditional boundaries. The study employs a dual-focus approach, investigating both the pedagogical potentials and challenges posed by AI in digital language instruction. The methodology consists of two key phases. The first phase involves a thorough literature review, drawing on the foundational language principles outlined by Lyons (1981) and examining scholarly works that elucidate the evolving landscape of AI in language education. This phase provides the theoretical framework for understanding the symbiotic relationship between language and AI. Additionally, insights from literature guide the identification of key themes and potential areas of impact, paving the way for a focused investigation.

By triangulating findings from literature, practical application analyses, and user perspectives, this study aims to offer a holistic understanding of the transformative impact of AI on language learning methodologies. The research design ensures a comprehensive exploration of both theoretical underpinnings and practical implications, contributing valuable insights to inform recommendations for the future integration of AI in language education.

Results and Discussion:

The integration of artificial intelligence (AI) into language learning methodologies has emerged as a focal point in contemporary educational discourse, heralding both promises and challenges. This section synthesizes the findings from the literature review and practical application analyses, delving into the multifaceted implications of AI in reshaping language acquisition methodologies.

Enhanced Pedagogical Potentials:

The literature review underscores AI's potential to enhance language instruction by offering personalized, adaptive learning experiences tailored to individual learners' needs (Luckin et al., 2016). AI-powered language learning applications leverage algorithms to analyze learners' performance data, identify areas of strengths and weaknesses, and deliver targeted feedback and recommendations (Purdy & Daugherty, 2017). This personalized approach fosters learner autonomy and engagement, empowering individuals to progress at their own pace and focus on areas requiring improvement.

Practical application analyses reveal that AI-driven language learning applications incorporate diverse teaching methodologies, ranging from gamification to interactive dialogue simulations (Kannan & Munday, 2018). These applications harness advanced technologies such as natural language processing (NLP) and machine learning to facilitate immersive language learning experiences (Sisman-Ugur & Kurubacak, 2019). By providing real-time feedback and interactive exercises, AI-powered tools create dynamic learning environments conducive to language acquisition.

Challenges and Limitations:

Despite the potential benefits, AI-driven language learning tools face several challenges and limitations. Literature highlights concerns regarding data privacy, information security, and the evolving role of human instructors in AI-mediated language instruction (Spitzer, 2016). Moreover, the deterministic nature of AI algorithms poses challenges in accommodating the diverse dimensions of interculturality and pragmatics in language learning (Goksel & Bozkurt, 2019).

Practical application analyses reveal that AI-powered language learning applications may exhibit limitations in interactive, dialogical turn-taking sequences due to their anticipative nature (Kannan & Munday, 2018). These tools often rely on predefined algorithms and lack the cognitive framework and intercultural awareness necessary for nuanced language interactions. Additionally, the effectiveness of AI-driven language instruction may vary across proficiency levels, with certain tools better suited for beginners than advanced learners.

Conclusion

In conclusion, the integration of artificial intelligence (AI) in language learning holds the potential to complement and intensify educational scenarios, particularly within a blended learning framework. Rather than aiming to replace language instructors, intelligent systems can serve as valuable tools, acting as scaffolds to support teachers in diverse language learning environments. The intricate nature of language, shaped not only by algorithms but also by intercultural and ever-changing pragmatic, semantic, and stylistic variables, emphasizes the indispensable role of human language experts in situating complex intercultural pragmatics within the classroom. While AI-powered tools can enhance language instruction, especially in remedial and repetitive exercises for beginners (e.g., A1/A2 levels), limitations arise in interactive, dialogical turn-taking sequences due to their anticipative and deterministic nature. These tools often rely on limited knowledge resources and lack a cognitive framework and intercultural awareness. Therefore, it is reasonable to assert that certain AI tools with current limitations are unlikely to replace language instructors in the near future. The narrative of AI has never been about replacing face-to-face language instruction but rather enriching or intensifying blended learning scenarios or self-regulated learning. Although AI tools for language learning are yet to perfect algorithms for capturing the diverse dimensions of interculturality and pragmatics in a language, ongoing research suggests advancements in natural language processing, speech recognition, and chatbot technologies in the coming years.

Recommendations for Future Integration:

To harness the full potential of AI in language learning, it is essential to address the identified challenges and limitations. Literature suggests the need for ongoing research and development to advance natural language processing, speech recognition, and chatbot technologies (Rao, 2017). Moreover, efforts should be made to integrate AI-powered tools within a blended learning framework, complementing rather than replacing human instructors (Mitchell et al., 2018). Practical recommendations include incorporating cultural and pragmatic dimensions into AI algorithms to enhance intercultural awareness and sensitivity (Sisman-Ugur & Kurubacak, 2019). Additionally, AI-driven language learning applications should prioritize learner-centered design principles, ensuring accessibility and inclusivity for diverse learner populations (Purdy & Daugherty, 2017).

In conclusion, the integration of AI in language learning methodologies offers exciting opportunities to revolutionize language instruction. By leveraging advanced technologies and personalized learning approaches, AI-powered tools have the potential to enhance learner engagement and facilitate meaningful language acquisition experiences. However, addressing challenges related to data privacy, interculturality, and the evolving role of human instructors is essential to ensure the responsible and effective integration of AI in language education. As AI continues to evolve, ongoing research and collaboration between educators, technologists, and policymakers will be critical in shaping the future of language learning in the digital age.

REFERENCES

- [1] S. M. Metev and V. P. Veiko, *Laser Assisted Microtechnology*, 2nd ed., R. M. Osgood, Jr., Ed. Berlin, Germany: Springer-Verlag, 1998.
- [2] J. Breckling, Ed., *The Analysis of Directional Time Series: Applications to Wind Speed and Direction*, ser. Lecture Notes in Statistics. Berlin, Germany: Springer, 1989, vol. 61.
- [3] S. Zhang, C. Zhu, J. K. O. Sin, and P. K. T. Mok, "A novel ultrathin elevated channel low-temperature poly-Si TFT," *IEEE Electron Device Lett.*, vol. 20, pp. 569–571, Nov. 1999.
- [4] M. Wegmuller, J. P. von der Weid, P. Oberson, and N. Gisin, "High resolution fiber distributed measurements with coherent OFDR," in *Proc. ECOC'00*, 2000, paper 11.3.4, p. 109.
- [5] R. E. Sorace, V. S. Reinhardt, and S. A. Vaughn, "High-speed digital-to-RF converter," U.S. Patent 5 668 842, Sept. 16, 1997.
- [6] (2002) The IEEE website. [Online]. Available: <http://www.ieee.org/>

- [7] M. Shell. (2002) IEEEtran homepage on CTAN. [Online]. Available: <http://www.ctan.org/tex-archive/macros/latex/contrib/supported/IEEEtran/>
- [8] FLEXChip Signal Processor (MC68175/D), Motorola, 1996.
- [9] "PDCA12-70 data sheet," Opto Speed SA, Mezzovico, Switzerland.
- [10] A. Karnik, "Performance of TCP congestion control with rate feedback: TCP/ABR and rate adaptive TCP/IP," M. Eng. thesis, Indian Institute of Science, Bangalore, India, Jan. 1999.
- [11] J. Padhye, V. Firoiu, and D. Towsley, "A stochastic model of TCP Reno congestion avoidance and control," Univ. of Massachusetts, Amherst, MA, CMPSCI Tech. Rep. 99-02, 1999.
- [12] Wireless LAN Medium Access Control (MAC) and Physical Layer (PHY) Specification, IEEE Std. 802.11, 1997.
- [13] Blauw, S. (2020). When artificial intelligence lost in translation is—The Correspondent [Newspaper]. <https://thecorrespondent.com/244/when-artificial-intelligence-lost-in-translation-is/32271696688-aef1110e>
- [14] CIO. (2018). What is Artificial Intelligence? CIO Whitepapers Review. <https://whatis.ciowhitepapersreview.com/definition/artificial-intelligence/>
- [15] Dodigovic, M. (2005). Artificial intelligence in second language learning: Raising error awareness. Biannual Publication, Revista Lengua y Cultura, Vol. 1, No. 2, 1-6. Multilingual Matters.
- [16] Ferreira, A., Moore, J., & Mellish, C. (2007). A Study of Feedback Strategies in Foreign Language Classrooms and Tutorials with Implications for Intelligent Computer-Assisted Language Learning Systems (Vol. 17). <http://homepages.inf.ed.ac.uk/jmoore/papers/ijaied07.pdf>
- [17] Goksel, N., & Bozkurt, A. (n.d.). Artificial Intelligence in Education: Current Insights and Future Perspectives (S. Sisman-Ugur, Ed.).
- [18] Kannan, J., & Munday, P. (2018). New Trends in Second Language Learning and Teaching through the lens of ICT, Networked Learning, and Artificial Intelligence. *Círculo de Lingüística Aplicada a La Comunicación*, 76(0), 13–30. <https://doi.org/10.5209/CLAC.62495>
- [19] Lisovets, V. (2017). Essentials of Artificial Intelligence for Language Learning. Intellias - Intelligent Software Engineering. <https://www.intellias.com/how-ai-helps-crack-a-new-language/>
- [20] Lotze, N. (2018). Präsenzunterricht adé? Künstliche Intelligenz fürs Sprachenlernen? *Magazin Sprache*. <https://www.goethe.de/de/spr/mag/dsk/21290629.html>
- [21] Luckin, R., Holmes, W., Griffiths, M., Corcier, L. B., Pearson (Firm), & University College, L. (2016). Intelligence unleashed: An argument for AI in education. <https://www.pearson.com/content/dam/corporate/global/pearson-dot-com/files/innovation/Intelligence-Unleashed-Publication.pdf>
- [22] Mitchell, T., et al. (2018). Never-ending learning. *Communications of the ACM*, 61(5), 103–115. <https://doi.org/10.1145/3191513>
- [23] Merse (Eds.), Digital Teaching and Learning: Perspectives for English Language Education. Narr Francke Attempto.
- Strasser, T. (2020b). Explainer videos in the EFL-classroom. *Praxis Englisch*, 2/2020(Digitally enhanced).



Modeling of Model-Free Adaptive Perturbation-based Extremum Seeking Control as Computational Optimization Problem

Okkes Tolga Altinoz*¹

¹Department of Electrical and Electronics Engineering, Ankara University, Turkey

**(taltinoz@ankara.edu.tr) Email of the corresponding author*

Abstract – Traditional control systems focuses on the problem to reach and stay at a given reference point, generally an equilibrium point. Generally, this point is calculating with a given design specifications. However, for some problems it is hard to calculate that point since it is an optimum point for the design specifications, which is an optimization problem. In addition, at the real word applications the system model generally is not available or not accurate. Therefore model-free approaches are needed to solve these problems with a given optimization problem. Therefore, tracking an optimum point for a given objective function for a model-free problems can be solved by extremum seeking control (ESC) method. This control method contains some parameters that must be adjusted before applying to the problem like value of the gain or the frequency and amplitude of the sinusoidal signal in the control structure. For this reason, in this research the ESC is modeled as an optimization problem and its parameters are determined with optimization algorithms Genetic Algorithm, Differential Evolution and Particle Swarm Optimization algorithms. The results showed that the initial study for determining the control parameters greatly improves the performance of the ESC algorithm.

Keywords – Adaptive Control, Extremum Seeking Control, Optimization, Genetic Algorithm, Evolutionary Computation.

I. INTRODUCTION

Traditional control algorithms like compensators or PID controller deals with the given reference signals which are step, ramp, or parabola-based input signals. It is desired from traditional control systems to drag the output signal with respect to the given design specifications. This reference value is needed to be calculated in the control problems with respect to the given objectives. Therefore, refence value should be calculated with respect to the given objective. In addition, the model of the system may not available. Therefore, to solve these problems the method named as extremum seeking control (ESC) is proposed by Krstic in 2000 [6,7]; Ariyur and Krstic in 2003 [1]. Even it is proposed in 2003, the studies for extreme seeking dates back until 1922 [5].

In ESC the aim is to react to the maximum or minimum (extremum) of the objective function and follow that point under the change on the control system [2]. Anti-lock braking system can be given as an example so that the pressure on the breaking can led the car stop in a short distance [3]. Therefore, ESC can be applicable for this problem to determine the optimum value on the objective function under different road and wheel conditions that corresponds to the dynamic change on the control system. Another example can be given to tuning of the PID controller [4] where the cost function is defined as the difference between actual response and desired response. Another example is from the flight formation that the minimization of the unknown vortex field in formation flight is the objective function of the ESC [8]. Similarly, ESC is applied to Wiener type systems [9], vehicle source seeking [10], swarm seeking problem [11], and flow control [12].

In this research, the parameters of the ESC algorithm are optimized by using Genetic Algorithm (GA), Differential Evolution (DE), and Particle Swarm Optimization (PSO) algorithms. The motivation of this work is to determine the control parameters that needs to be decided by try-error manner. By using a

single objective optimization algorithm, the optimum parameters are decided and obtained more smooth output signals that will be explained in the next section.

This paper begins with the introduction section. Then the Extremum seeking Control and optimization algorithms are explained briefly. Finally, the implementation/design process will be explained. At the end of this research the conclusion will be given with the future study.

II. MATERIALS AND METHOD

This section is for the explaining the fundamental and design of the ESC. After that the three optimization algorithms are explained briefly.

A. Extremum Seeking Control

Figure 1 graphically summarize the ESC method. The SEC is a method for stabilizing the system and at the same time obtain the maximum performance with respect to the objective function. Since ESC is related to optimum finding problem, it is related to the optimal control Also since the ESC do not depend on the model of the system it is related with the model predictive control. The control approach is based on the solving of the problem given below.

$$\min J(x, u, y(0), y(T), t) \quad (1)$$

subject to

$$\dot{x} = f(x, u)$$

where x is the state, u is the control input, t is time $t=0 \dots T$ and y is the output of the plant.

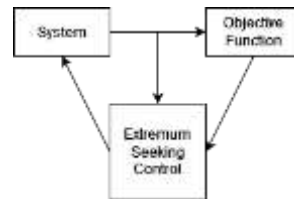

Figure 1 The General block representation of the extremum seeking control.

There are different ESC schemes are proposed in the literature. In this research the perturbation-based ESC is selected because of its efficiency empirically and mathematically proved in literature.

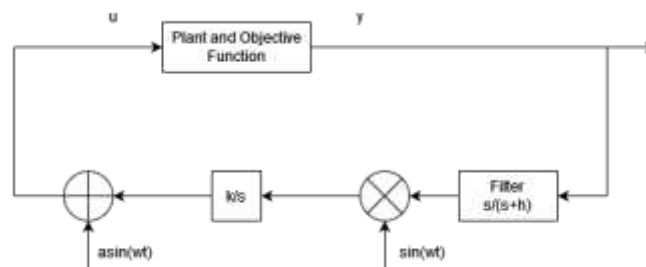

Figure 2 Graphically demonstration of the perturbation based continuous maximization method.

The perturbation signal as in sinusoidal form with a frequency and amplitude is applied to the system. The aim of this change on the signal is to help to calculate gradient information of the objective function (J).

The frequency w should be selected for sufficiently large to a unique exponentially stable periodic solution of period $(2\pi/w)$ for the system given in Figure 2 [13]. The output is converged with rate of second derivation of the objective function. In Figure 2 only high pass filter is demonstrated so that the DC/Average of the output signal is eliminated to compare the added/multiplied perturbation and perturbation of the output signal. Is both at the same sign than it is the 'on' signal (by multiplying) and if one of them at the different sign than it generates 'off' signal with a rate of a gain.

The example is given in Figure 3. The plant and objective function are defined as

$$J = 100 - (10 - u)^2 \tag{2}$$

The parameters for the high-pass filter are $(s/(s+5))$, the gain is 30 and the amplitude and frequency of the perturbation signal is 0.3 and 30 rad/s respectively.

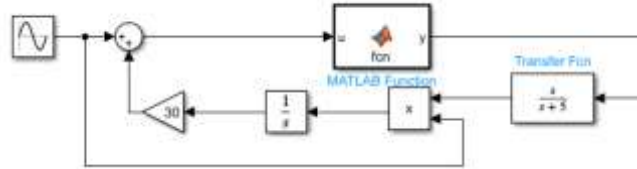

Figure 3. The example for the perturbation-based Extremum Seeking Control

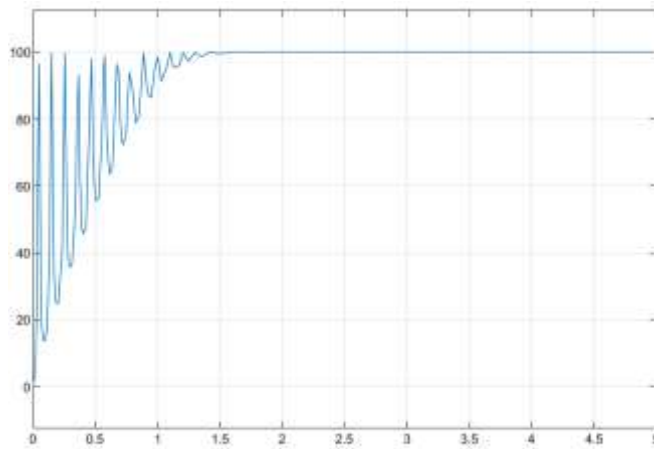

Figure 4 The objective function value with respect to the time.

The obtained controller output (objective function) is given in Figure 4 and the generated input signal is given in Figure 5. From the Eq. 2, it is clear the maximum value of the objective function is 100 and this value is obtained in approximately 2 sec. until it reaches to the steady state there is a huge oscillation on the output signal due to the perturbation of the signal added and multiplied in ESC.

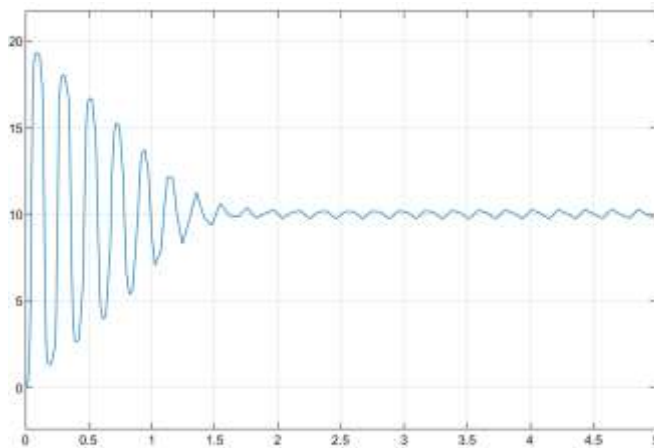

Figure 5 Generated control input u .

The performance improvement can be discussed with respect to the response speed and the output accuracy with the oscillation. The oscillation is important because in the real-world implementations that oscillation also causes to change the physical properties of the system. For this reason, in this research the

ESC parameters are optimized with single objective optimization algorithms. Figure 6 shows three blocks that can be optimized.

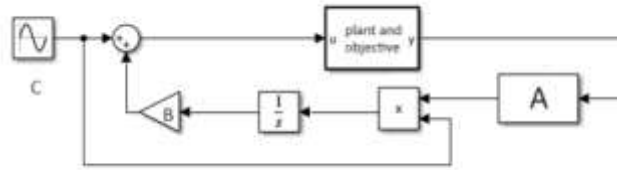

Figure 6 The general description of the permutation-based ESC for the external single objective optimization.

In block A, the cut-off frequency, in block B the gain, and in block C the amplitude and frequency of the perturbation signal can be optimized for a better response and performance. For this purpose, three single objective optimization algorithms are applied to the parable and their performances will be compared.

B. Optimization

In this research three single objective optimization algorithms Genetic Algorithm (GA) [14], Particle Swarm Optimization (PSO) [15] and Differential Evolution (DE) [16] are applied to the problem defined at the previous sub-section. In this section these algorithms are defined briefly. The GA is the evolutionary algorithm that has three parameters crossover mutation and selection which are also applicable for DE. However, in DE these operator's order differs. Unlike GA and DE, the PSO is a nature inspired optimization algorithm that mimics the swarm behaviour.

All these three algorithms begin with the randomly initialized population. In GA, the members are selected from population and their chromosomes are crossover with each other and new set of offspring is generated. These offspring applied to mutation operator and finally the best members survived to the next generation. In DE, the offspring is generated with a predefined function that is formulated with randomly selected members in the population and some gain values. The best members among population selected and continue to the next generation. In PSO, the members have population and velocity, and these properties are updated at each iteration. The position and velocity are updated by using the best member's position in the population and the best position of each member. At each iteration these two properties are updated.

Table 1. Parameter values and corresponding objective values for each optimization algorithm.

Genetic Algorithm				
J	h	k	a	w
3.849	8.9344	11.8681	0.3625	20.3767
3.676	9.0596	15.4391	0.4255	36.8462
3.412	9.9792	14.4036	0.4866	39.1558
3.288	9.8988	15.1369	0.4966	41.5736
3.526	9.9836	12.6690	0.4958	35.8985
Particle Swarm Optimization				
2.783	9.91	15.5088	0.4865	49.9827
2.711	9.9977	10	0.4982	29.1516
2.78	9.9587	14.9707	0.5	49.9746
2.776	9.9990	16.0636	0.4889	50
2.782	9.7655	15.0856	0.4988	50
Differential Evolution				
2.783	9.8348	15.2574	0.4938	50
2.777	9.9723	15.3348	0.5	50
2.713	10	10	0.5	29.1271
2.703	9.9972	10.2108	0.5	29.4514
2.712	10	10.0056	0.5	29.1228

III. IMPLEMENTATIONS AND RESULTS

The implementations are repeated 5 times in this research with the fair comparison that all algorithms have 20 population and 100 iterations/generations. As explained in Figure 6, there are 4 parameters that are optimized with are the cut-off frequency (h), the gain (k) the amplitude and frequency of the sinusoidal perturbation (a and w , respectively) ($[h,k,a,w]$). The lower boundaries of these parameters are [1, 10, 0.1, 10] and the upper boundaries are [10, 50, 0.5, 50].

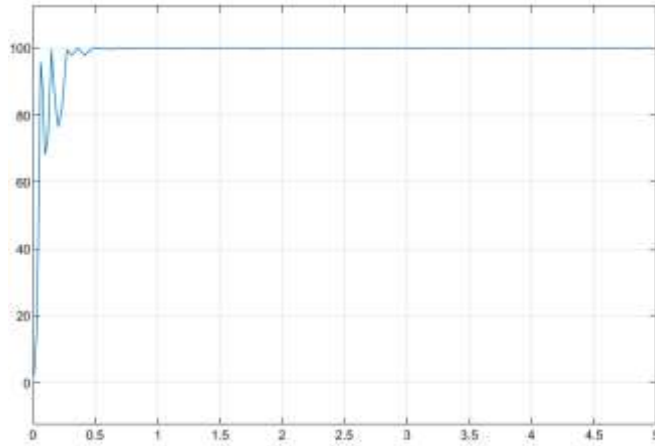

Figure 7 The obtained objective function value with respect to the time.

The objective function for these algorithms is defined as

$$J = 10 * t_s + \frac{1}{t_0} \int_T^{T-t_0} (100 - y(t))^2 dt \quad (3)$$

where t_s is the settling time, $y(t)$ is the output signal, and the integral is calculated as the average of the output signal for a defined relatively short time window t_0 .

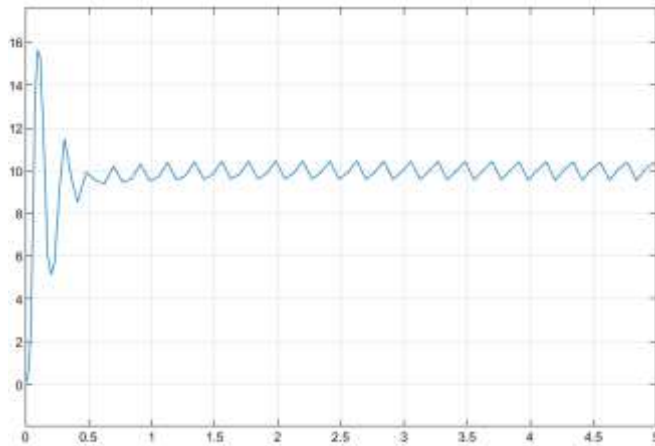

Figure 8 Optimized control input u .

Table 1 gives the obtained parameters for three optimization algorithms for 5 different independent runs. Among these three optimization algorithms DE gives the best results in general among all of them, and the best solution set with the lowest objective value is selected and the obtained plots are given in Figure 7 and 8. From the figures the response time reduces to 0.5 approximately and the oscillation reduces greatly.

IV. CONCLUSION

The Extremum seeking Control method is a model free adaptive method for solving control problems. The ESC has matured in 70s, however in 2000s the perturbation-based Esc is proposed to increase the efficiency the control problem. However, this problem has some parameters that must be determined to get a better response. For this purpose, in this research these parameters are optimized by using the single objective optimization algorithms and the results showed that the response for the optimized parameters greatly increase the speed of the response and decrease the oscillation of the signals.

REFERENCES

- [1] K.B. Ariyur and M. Krstic, "Real time optimization by extremum seeking control," Wiley-Interscience, 2003.
- [2] C. Zhang, R. Ordonez, "Extremum seeking control and applications," Advances in Industrial Control, Springer, 2012.
- [3] S.V. Drakunov, U. Ozguner, P. Dix, B. Ashrafi, "ABS control using optimum search via sliding modes," IEEE Transactions on Control Systems, Vol. 3, pp. 79-85, 1995.
- [4] N. Killingsworth, M. Krstic, "Control of formation flight via extremum seeking," IEEE Control Magazine, vol. 26, pp.70-79, 2006.
- [5] M. Lablanc, "L'électrification des chemins de fer au moyen de courants alternatifs de fréquence élevée," Review on Generation Electrification, 1922.
- [6] M. Krstic, H. Wang, "Design and stability analysis of extremum seeking feedback for general nonlinear system," Automatica, vol. 36, no. 2, pp. 595-601, 2000.
- [7] M. Krstic, "Performance improvement and limitations in extremum seeking control," System Control Letter, vol. 39, no. 5, pp.313-326, 2000.
- [8] E. Lavretsky, N. Hovakimyan, A. Calise, "Adaptive extremum seeking control design," American Control Conference, pp.567-572, 2003.
- [9] B. Wittenmark, R. Evans, "Extremal control of wiener model processes," Conference on Decision and Control, pp. 4637-4642, 2002.
- [10] L. Fu, U. Özgüner, "Sliding mode in constrained source tracking with non-holonomic vehicles," International Workshop on Variable Structure Systems, pp. 30-34, 2008.
- [11] N. Ghods, M. Krstic, "Multiagent deployment over a source," IEEE Transactions on Control System Technology, pp. 1-10, 2011.
- [12] J. Creaby, Y. Li, J. Seem, "Maximizing wind turbine energy capture using multivariable extremum seeking control," Wind Engineering, Vol. 33, no. 4, pp. 361-387, 2009.
- [13] C. Zhang, R. Ordóñez, "Extremum-Seeking Control and Applications Numerical Optimization Based," Advances in Industrial Control, Approach-Springer-Verlag London, 2012.
- [14] D. Goldberg, "Genetic Algorithms in Search Optimization and Machine Learning," Addison-Wesley Professional, 1989.
- [15] J. Kennedy, R. Eberhart, "Particle Swarm Optimization," IEEE International Conference on Neural Networks. Vol. IV. pp. 1942-1948, 1995.
- [16] R. Storn, K. Price, "Differential evolution - a simple and efficient heuristic for global optimization over continuous spaces," Journal of Global Optimization, vol. 11, no. 4, pp. 341-359, 1997.



Tagging of Critical Medical Images Leveraging Clustering Approaches

Sezin Çağla Serficeli¹, Berke Udunman¹ and Emrah Inan^{1*}

¹Department of Computer Engineering, Izmir Institute of Technology, Turkey

*(emrahinan@iyte.edu.tr)

Abstract – Supervised learning methods rely on a large number of training samples with correct labels in order to learn to classify the given input. However, handcrafted labelling such a large dataset is a labour-intensive operation. To address this problem, we propose a clustering-based method with a labelling mechanism that accommodates the minimum effort of domain experts to generate ground truth images. The experimental setup of the hierarchical agglomerative clustering method shows promising results and can facilitate the efforts of domain experts by suggesting weakly supervised labels for the given X-ray images.

Keywords – Clustering, Medical Image Tagging, Kmeans, Agglomerativeclustering, DBSCAN

I. INTRODUCTION

Traditional supervised learning approaches require clearly labelled images. However, for open-source medical images, this is not applicable because of legal restrictions [1]. Due to the limited size of labelled images, it is inevitable to concentrate on traditional machine learning approaches rather than exploiting deep learning frameworks. To alleviate this issue, we introduce clustering based ground-truth suggestion technique that reduces the manual annotation process.

To evaluate the performance of the proposed technique, we use a limited number of condition annotated chest radiographs annotated with COVID-19, viral pneumonia, and healthy conditions. Similarly, Sünnetçi and et al [2] propose an AlexNet deep learning architecture with the dataset of chest X-rays of patients with COVID-19, pneumonia, and chest X-rays of normal healthy patients. It addresses the impact of the COVID-19 pandemic and the need for efficient diagnosis for effective treatment. In this experimental setup, the researchers try different machine learning classification models on the extracted features, about 1000 features, with the AlexNet deep learning architecture, and then use different accuracy measures to calculate the accuracy scores. The paper highlights the potential of machine learning to aid in the diagnosis of COVID-19 using chest X-rays and emphasises the importance of accurate and efficient diagnostic tools in the midst of the ongoing pandemic.

GazeGNN [3] addresses the problem of classifying chest X-rays using a novel eye-tracking technique. According to the study, two widely used eye-tracking approaches for medical image classification are the two-stream architecture and the attention consistency architecture. GazeGNN, however, uses eye gaze as model input and directly uses raw eye gaze data without converting it into visual attention maps. Unlike mainstream approaches, it uses a graph to model the information in X-ray images as a single entity, allowing the graph neural network to extract insights from the graph. As depicted in the study, the model uses chest x-rays from CheX-pert, MIMIC-CXR, ChestX-ray14 and others.

Karagyris et al [4] present a three-step methodology involving data preparation, data collection and data post-processing. It consists of eye gaze information for interpretation of the chest X-ray dataset generated by an eye tracking system. Radiologists reviewed and reported on over 1000 images for the dataset. The study discusses the challenges of developing disease classifiers for medical images due to the high labour cost of annotating localised disease areas, the reliance on global labels, the limited

incorporation of expert knowledge, concerns about the explainability of deep neural network output, and potential problems with generalisation across different sources, scanners, and demographics. It also demonstrates how the dataset can be used with temporal heatmap and static heatmap experiments.

The paper is structured as follows. Section 2 presents the dataset and the proposed method. Section 3 presents the detailed experiments. Section 4 discusses the evaluation results. Finally, Section 5 concludes the study and outlines future directions.

II. MATERIALS AND METHOD

Figure 1 demonstrates that the dataset contains three different types of condition annotated chest radiographs. The chest x-ray dataset contains a total of 251 chest images. It includes chest images of people with COVID-19, viral pneumonia, and healthy conditions. This dataset is a critical resource for the medical and research community provided by the University of Montreal and Pranav Raikote [5].

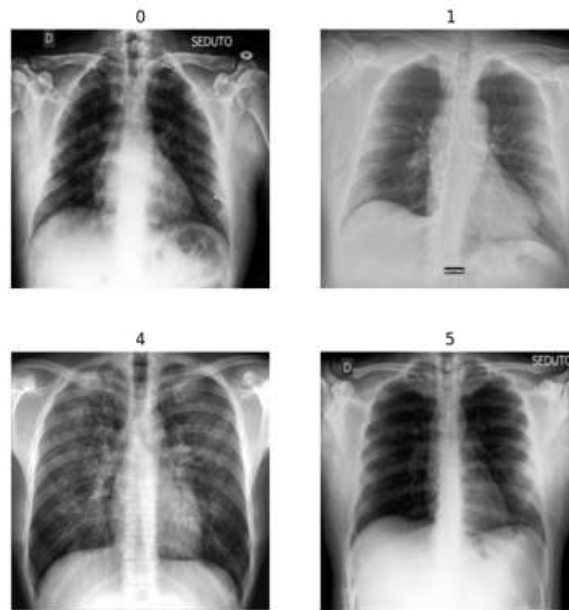

Fig. 1 Excerpts of the original chest x-rays

In our image pre-processing workflow, the first step was to resize the X-ray images and then convert them to grey scale. We then used the Histogram of Oriented Gradients (HOG) technique to highlight important features within the resized dataset.

The Histogram of Oriented Gradients feature extraction method helps to characterise the shape and appearance of objects. It is based on the collection of gradient directions across pixels within a defined spatial region known as a 'cell'. A 1D histogram is then constructed from these gradients, and the concatenation of these histograms forms the feature vector used for subsequent operations [6]. In the chest x-ray dataset, the HOG feature extraction method was used to represent the characteristics of the three different test groups, as illustrated in Figure 2.

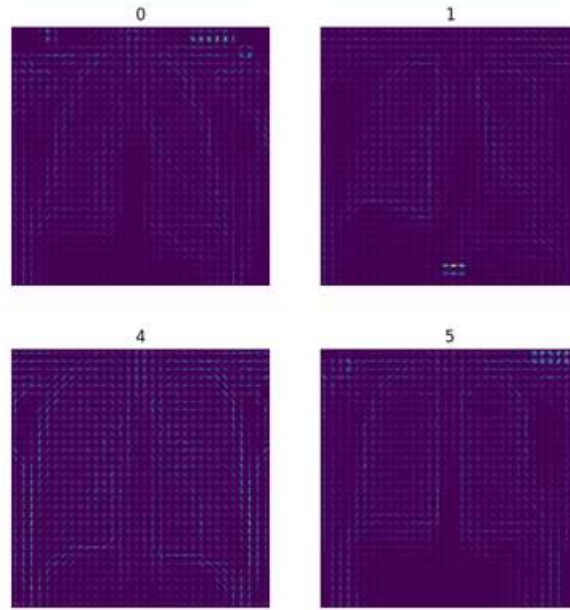

Fig. 2 Samples extracted features with the HOG descriptor

III. RESULTS

Three pre-processing algorithms (StandardScaler, MinMaxScaler and RobustScaler) are leveraged to standardise, normalise, and robustly scale the HOG features obtained from chest X-ray images. These pre-processed features are then subjected to various dimensionality reduction algorithms such as t-SNE and PCA. The t-SNE method is used to visualise high-dimensional data, especially images, by reducing the high-dimensional data to two-dimensional data while preserving the distances between data points [7]. In addition, Principal Component Analysis (PCA) is a method used to reduce the dimensionality of data sets to improve interpretability while minimising information loss. This is achieved by generating new uncorrelated variables that sequentially maximise variance [8]. With these algorithms, the resulting two-dimensional representations are visualised in a grid of scatterplots. Each row in the grid corresponds to a different dimensionality reduction algorithm, and each column represents a different preprocessing algorithm depicted on Figure 3.

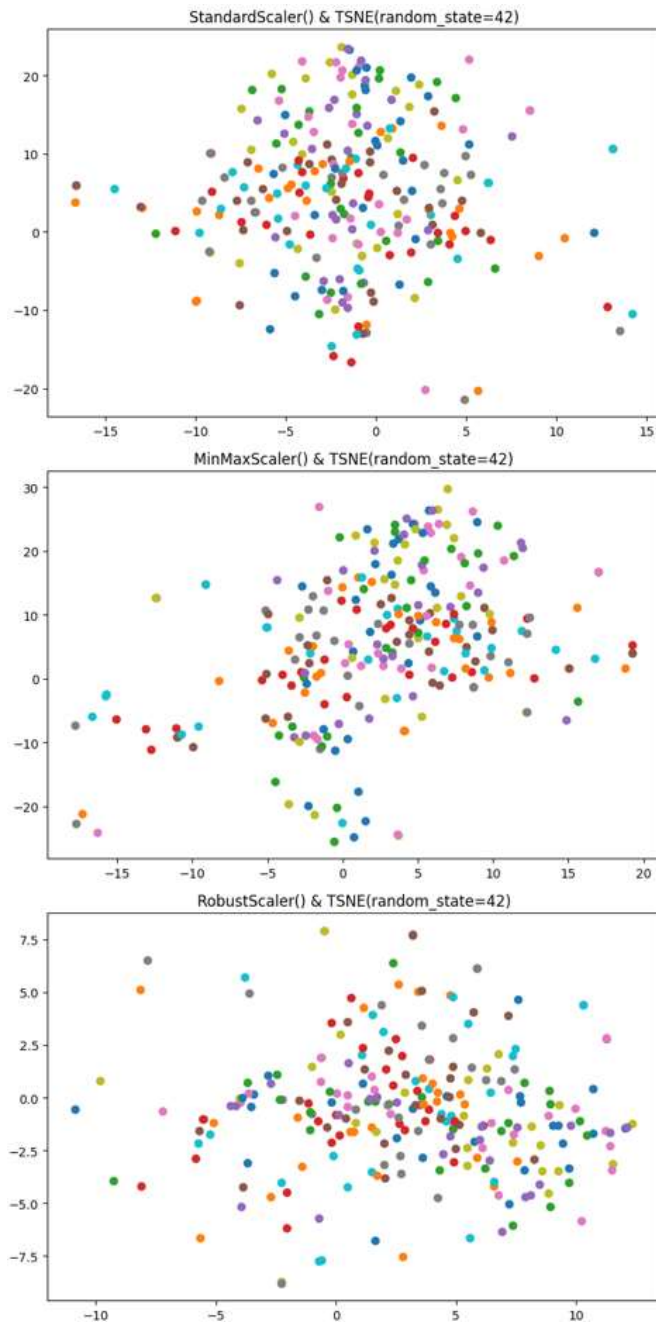

Fig. 3a Pre-processed and dimensional reduced data points with t-SNE

To visualise the steps in the discussion, KMeans, AgglomerativeClustering and DBSCAN are used for clustering using the pre-processed and reduced dimensionality features as shown in Figure 4.

The graph applied with MinMaxScaler and t-SNE shows less overlap between data points, which supports the effectiveness of MinMaxScaler and t-SNE for improved clustering results as denoted in Figure 3. For these reasons, the selected pre-processed dataset is the one where MinMaxScaler and t-SNE were applied.

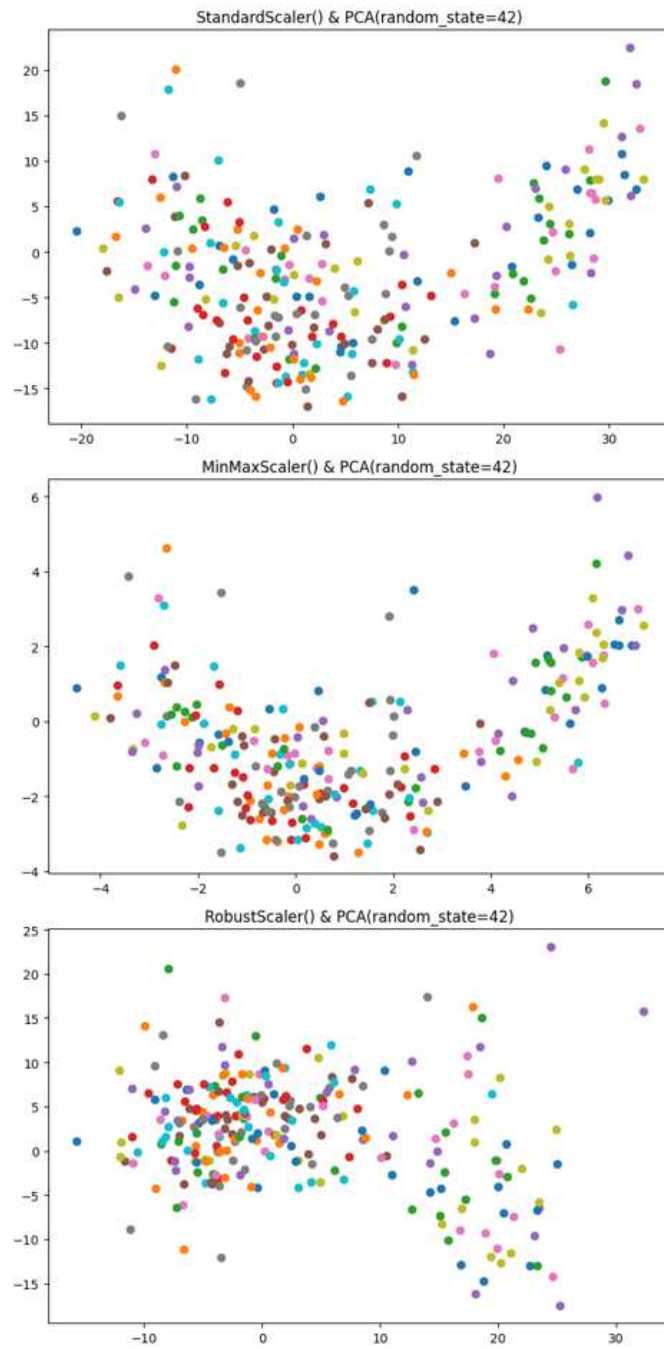

Fig. 3b Pre-processed and dimensional reduced data points with PCA

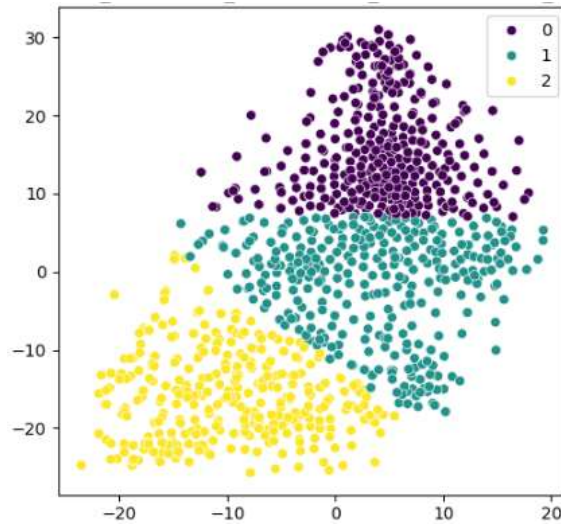

Fig. 4a The illustration of the clustered dataset after applying KMeans

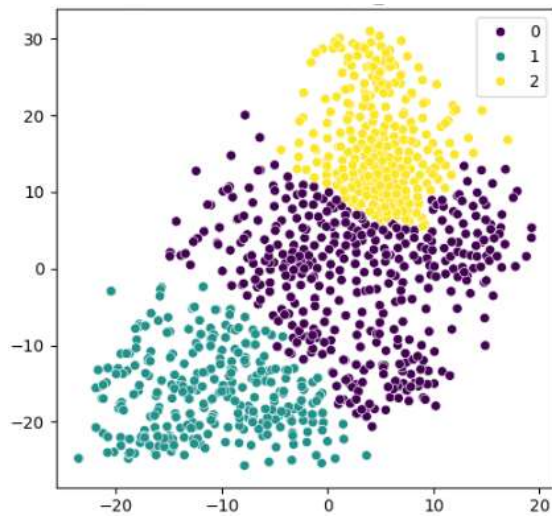

Fig. 4b The illustration of the clustered dataset after applying Agglomerative Clustering

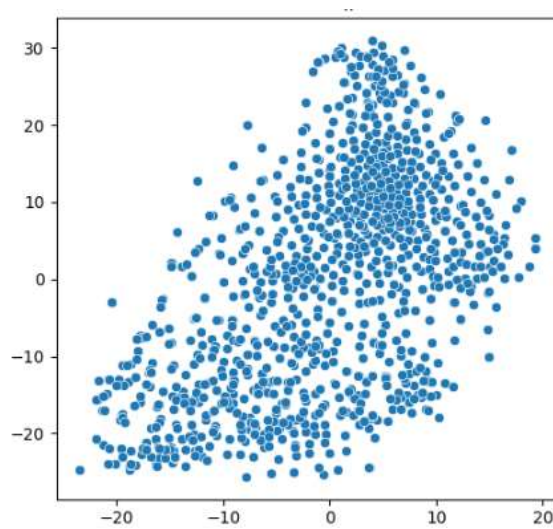





Fig. 4c The illustration of the clustered dataset after applying DBSCAN

IV. DISCUSSION

As a final step, we demonstrate excerpts of the generated labels for randomly selected X-ray images, as illustrated in Table 1.

Table 1. Examples of actual and predicted images after clustering method

Image	Actual	Predicted
	covid	covid
	covid	covid
	covid	normal
	covid	viral_pneumonia

We used the hierarchical agglomerative clustering method with MinMaxScaler and t-SNE. For the first two excerpts, our method predicts the correct clusters for the X-ray image labelled "covid". For the third one, it suggests as normal case, but due to the ambiguity of the given X-ray image, it is actually related to the "covid" sample. For the last one, it becomes more difficult to distinguish such a complex case because these cases are inherently similar to each other.

V. CONCLUSION

In this study, the hierarchical agglomerative clustering method is proposed to suggest candidate annotations between the labels "covid", "normal" and "viral_pneumonia". Our method shows promising results, and we will explore further directions, especially with the transformer-based model Vit [9].

REFERENCES

- [1] C. W. L. Ho, D. Soon, K. Caals, & J. Kapur, "Governance of automated image analysis and artificial intelligence analytics in healthcare". *Clinical radiology*, 74(5), 329-337. 2019
- [2] K. M. Sünnetçi, A. Alkan, and E. Tar, "Göğüs X-Ray görüntülerinin AlexNet tabanlı sınıflandırılması" [AlexNet-based classification of chest X-Ray images]. *Journal of Computer Science*, IDAP-2021(Special), 375-384. <https://doi.org/10.53070/bbd.989192>, 2021.
- [3] B. Wang, H. Pan, A. Aboah, Z. Zhang, E. Keles, D. Torigian, B. Turkbey, E. Krupinski, J. Udupa, and U. Bagci, U. "GazeGNN: A Gaze-Guided Graph Neural Network for Chest X-Ray Classification". In *Proceedings of the IEEE/CVF Winter Conference on Applications of Computer Vision (WACV)* (pp. 2194-2203). 2024.

- [4] A. Karargyris, S. Kashyap, I. Lourentzou, J. T. Wu, A. Sharma, M. Tong, S. Abedin, D. Beymer, V. Mukherjee, E. A. Krupinski, and M. Moradi. "Creation and validation of a chest X-ray dataset with eye-tracking and report dictation for AI development". *Scientific Data*, 8(92). <https://doi.org/10.1038/s41597-021-00863-5> , 2021.
- [5] The source of the dataset [Online], Available: <https://www.kaggle.com/datasets/pranavraikokte/covid19-image-dataset/data>
- [6] P. Carcagnì, M. Del Coco, M. Leo, and C. Distantè "Facial expression recognition and histograms of oriented gradients: a comprehensive study". *SpringerPlus*, 4(1), 1-25. 2015.
- [7] L. vd Maaten, and G. Hinton. "Visualizing data using t-sne". *Journal of machine learning research*, 9(Nov), 2579-2605. 2008.
- [8] I. T. Jolliffe, and J. Cadima. "Principal component analysis: a review and recent developments". *Philosophical transactions. Series A, Mathematical, physical, and engineering sciences*, 374(2065), 20150202. <https://doi.org/10.1098/rsta.2015.0202>, 2016.
- [9] A. Dosovitskiy, L. Beyer, A. Kolesnikov, D. Weissenborn, X. Zhai, T. Unterthiner, ... & N. Houlsby, "An image is worth 16x16 words: Transformers for image recognition at scale". arXiv preprint arXiv:2010.11929. 2020



Veri Kaynağı Olarak Sohbet Robotları: Kamu Yönetimi Disiplininde Örnek Bir Araştırma

Ecem Buse Sevinç Çubuk^{1*}

¹*Yönetim Bilişim Sistemleri / Söke İşletme Fakültesi, Aydın Adnan Menderes Üniversitesi, Türkiye*

**(ecembuse.sevinc@adu.edu.tr)*

Özet – Son yıllarda yapay zeka (YZ) ve makine öğrenimi bilimsel araştırmaların görünümünü değiştirmektedir. Bu kapsamda, *chatbot* (sohbet robotu) teknolojisinin, özellikle de ChatGPT'nin, kayda değer bir YZ dil modeli olarak ortaya çıkmasıyla YZ'nin bilimsel araştırmalarda kullanımı konusunda tartışmalar artmaktadır. Sohbet robotlarının güvenilir, etkili ve araştırmacıların üretkenliğini artırmada yararlı olup olmadığı konusu da araştırmacıların gündeminde yer almaktadır. Bu çalışma, YZ'ye dayalı sohbet robotlarının veri kaynağı olarak kullanılmasını ele almaktadır. Çok miktarda metin verisini işleme ve insan benzeri yanıtlar üretmeye ek tartışmalı metin oluşturma yeteneği ile sohbet robotları, son yıllarda bilimsel araştırmaların dikkatini çekmiştir. Bu nitel araştırma, Kamu Yönetimi disiplininde yapılacak örnek bir çalışmada OpenAI tarafından geliştirilen ChatGPT ve Google DeepMinds tarafından geliştirilen Gemini'nin ücretsiz sürümlerinin veri kaynağı olarak performansını incelemektedir. Bu çalışma aynı zamanda sohbet robotlarının kavramsal mühendisliğindeki sonuçlarına değinmektedir. Çalışmanın temel amacı önde gelen iki sohbet robotunun aynı araştırma konusu üzerindeki çıktılarını karşılaştırmaktır. Sohbet robotlarının bilimsel çalışmalarda ayrı bir yazar olarak değerlendirilme potansiyelinin tartışıldığı bu dönemde, bu çalışma akademisyenler, öğrenciler, editörler, araştırmacılar ve politika yapıcılar gibi YZ teknolojileri ile içerik üretimine ilgi duyan çeşitli gruplara başlangıç niteliğinde bir analiz sunmaktadır. Ayrıca çalışma, sohbet robotlarının bilimsel araştırmalarda kullanımına ilişkin potansiyel zorlukları ve etik kaygıları incelerken, YZ destekli inovasyon ile insan uzmanlığı arasında bir denge kurmanın önemine de dikkat çekmektedir.

Anahtar Kelimeler – Yapay Zeka, Kamu Yönetimi Disiplini, Yerel Yönetimler, Belediye Yatırımları, Sohbet Robotları, ChatGPT, Gemini

I. GİRİŞ

Sohbet robotu, son birkaç yılda büyük popülerlik kazanan gelişmiş bir doğal dil işleme teknolojisidir. Karmaşık sorgulara insan benzeri yanıtlar verme yeteneği, onu sohbet robotlarından yazma asistanlarına ve müşteri hizmetlerinden içerik oluşturmaya kadar çeşitli uygulamalar için başvurulan bir araç haline getirmiştir. Sistem, metin komutlarına yanıt vermek veya insanlarla diyalog kurabilmek için kullanabileceği çok büyük miktarda dil verisi üzerinde eğitilmiştir. Algoritma, önceki kelimelere dayanarak bir cümledeki sonraki kelimeyi tahmin edecek şekilde eğitilmiştir. Bu bilgiyi ise tutarlı cümleler ve paragraflar oluşturmak için kullanmaktadır. Sohbet robotları, internetten gelen büyük miktardaki veriler üzerinde eğitilmiştir ve bu eğitim ona neredeyse tüm konular hakkında kapsamlı bir bilgi kazandırmıştır. Ancak sohbet robotlarının etkisi teknolojik alanla sınırlı değildir. Yapay zeka (YZ) ve sohbet robotları gibi makine öğrenimi sistemlerinin geliştirilmesi, kavramların anlaşılmasında ve kullanılmasında önemli değişikliklere yol açmaktadır. Aynı zamanda kavramsal mühendislik için yeni fırsatlar açabilmekte ve çeşitli alanlarda anlayışımızı etkileyerek önemli çıkarımlar üretebilmektedir.

Tüm bu yetenekleri nedeniyle bu sistemlerin gelişimi, insanların teknolojiyle etkileşimini de dönüştürmüştür. Bu dönüşümlerden biri de bilimsel araştırmaların gelişiminde yaşanmaktadır. Sohbet robotlarının evrimi, veri işleme, hipotez oluşturma ve iş birliği de dahil olmak üzere çok çeşitli

yeteneklere sahip olması onları bilimsel arařtırmaları ilerletmede paha biçilmez bir araç haline getirmektedir. YZ teknolojisi ilerlemeye devam ettikçe bilimsel arařtırmanın geleceğini şekillendirecek daha fazla gelişme ve yeniliğin beklenmesi kaçınılmazdır. Bu nedenle, bilimsel ve akademik topluluklarda sohbet robotlarındaki, özellikle ChatGPT'deki, arařtırma ve geliřtirmeye eğilim gittikçe artmaktadır [1]. Ancak, ChatGPT gibi YZ tabanlı teknolojiler, kavramsallařtırma ve bilgiyi işleme dönüşürmekte ve bizim bu dönüşümün çıktılarıyla etkileşime geçme şeklimizi de önemli ölçüde deęiřtirmektedir. Bu nedenle, sohbet robotlarının dil üretme yetenekleri etik kaygıları artırabilir ve kavramsal mühendislik ihtiyacını doğurabilir.

Sohbet robotlarının insan yazısına benzeyen ve beklenenden daha düşük düzeyde intihal içeren metinler üretme yeteneęi nedeniyle, yakın zamanda bu teknolojilerin bilimsel yazı üzerindeki etkisini ele alan bir dizi makale yayınlanmıřtır. Örneęin Dowling ve Lucey [2], ChatGPT'nin finans arařtırmalarında oldukça faydalı bir araç ve arařtırma asistanı olabileceęi sonucuna ulařmıřtır. Ancak, sohbet robotlarının orijinal yazılar üretme kapasitesi akademi ve bilimsel çalışmalar adına çeřitli sorular ve zorlukları beraberinde getirmiřtir. Bazı arařtırmacılar, geliřmiş öğrenme olanakları nedeniyle sohbet robotlarını benimserken, dięerleri etik sorunlar, güvenilirlik ve yanıltıcı verilerle ilgili endişelerini dile getirmiřtir [3]. Sohbet robotlarının etkileyici yazma yeteneklerine rağmen hâlâ insan muhakemesine ihtiyaç duyulmaktadır [4]. Sohbet robotlarının bilimsel makale yazarı olarak kabul edilip edilmeyeceęi sorusu řu anda bilimsel uzmanlar arasında tartıřılmakta; hatta bazıları özellikle ChatGPT'ye yazarlık kredisi vermektedir [5]. *Science* ve *The Lancet* gibi bazı önde gelen dergiler, ChatGPT ve benzer yapay zeka tarafından oluřturulan sohbet robotlarının kullanımına iliřkin yönergelerini güncellemiřtir.

Bu çalışmada sohbet robotlarının Kamu Yönetimi disiplinde yapılan arařtırmalarda veri kaynaęı olarak kullanımını ele alınmaktadır. Bu amaçla, Türkiye'de belediyeçilik faaliyetlerin siyasi partilere göre deęiřimi hakkında ChatGPT ve Gemini tarafından saęlanan analizler karřılařtırılmıřtır. Bu karřılařtırma neticesinde, sohbet robotlarının bu tür arařtırma görevlerinde sergiledięi performansın kabul edilebilirlięi tartıřmasına Kamu Yönetimi disiplini perspektifinde katkıda bulunmak istenmiřtir.

II. MATERYAL VE YÖNTEM

Çalışmada örnek olarak, Türkiye'de belediyeçilik faaliyetlerin siyasi partilere göre deęiřimi ele alınmıřtır. ChatGPT ve Gemini'ye bu soru yöneltilmiş ve farklı partiler tarafından yönetilen belediyelerin öncelikle yatırım ve proje alanları hakkında bilgi vermesi istenmiřtir.

ChatGPT, OpenAI tarafından geliřtirilen ve diyalog konusunda uzmanlařmış bir yapay zeka sohbet robotudur. Bu sohbet robotu, denetimli ve takviyeli öğrenme teknikleriyle ince ayar yapılmış büyük bir dil modeline dayanmaktadır. Genellikle GPT (*Generative Pre-trained Transformer*) olarak bilinen Üretici Önceden Eęitilmiş Dönüřtürücüler, dönüřtürücü mimarisini kullanan bir sinir aęı modeli ailesidir. OpenAI tarafından sunulan GPT-3.5 mimarisi ücretsiz olarak kullanılabilirken; son versiyonu olan GPT-4, ChatGPT Plus kullanıcıları tarafından deneyimlenebilmektedir.

Gemini ise Google DeepMind tarafından geliřtirilen ve Google'ın bugüne kadar oluřturduęu en yetenekli genel yapay zeka modeli olarak tanımladıęı çok modlu büyük dil modelleri ailesidir. Gemini; Ultra, Pro ve Nano olmak üzere üç farklı biçimde çalışmak için optimize edilerek, veri merkezlerinden mobil cihazlara kadar pek çok aracı teknolojide çalışabilecek biçimde tasarlanmıřtır. Gemini, yapay zeka modellerinin bilgi ve problem çözme yeteneklerini test etmek için en popüler yöntemlerden biri olan MMLU (*Massive Multitask Language Understanding* – Devasa Çok Görevli Dil Anlama) konusunda insan uzmanlarından daha iyi performans gösteren ilk modeldir. MMLU, çok çeřitli dil görevlerinde aynı anda makine öğrenimi modelinin eęitilmesini içermektedir. Bu çeřitlilik, basit metin sınıflandırmasından soru cevaplama, duygu analizi ve hatta çeřitli diller arasında çeviri yapma gibi daha karmařık zorluklara kadar deęiřebilmektedir. “Devasa” (*Massive*) ile kastedilen yalnızca ilgili verilerin boyutu deęil aynı zamanda modelin öğrenmesi beklenen çeřitlilięi ve görev sayısını da ifade etmektedir.

ChatGPT ve Gemini sohbet robotlarının, konuyu anlama, irdeleme, cevap verme ve yönlendirme performansları dört temel soru ekseninde incelenmiřtir:

- Türkiye'de belediyeçilik faaliyetleri siyasi partilere göre farklılık göstermekte midir?
- Siyasi partilere göre belediyeçilik faaliyetlerindeki farklılıklar nelerdir?

- Siyasi partilere göre belediyeçilik faaliyetlerindeki farklılığın nedenleri nelerdir?
- Siyasi partilerin belediyeçilik faaliyetlerini sınıflandırırken nasıl bir yol izlenmiştir?

Bu sorulara ek olarak, sohbet robotlarının bilimsel çalışmalara insan benzeri yaklaşımını incelemek için sunduğu çıktılarının sınırlılıklarına dair yorum sunma ve önerilerde bulunma yeteneği incelenmiştir. Böylelikle, bilimsel çalışma yaparken insanların taşıdığı etik kaygıları sohbet robotlarının ne ölçüde taşıdığı değerlendirilmiştir.

III. BULGULAR

Araştırmada ilk olarak ChatGPT ve Gemini'ye Türkiye'de belediyeçilik faaliyetlerinin siyasi partilere göre değişiklik gösterip göstermediği sorulmuştur. Her iki sohbet robotu da değişiklik gösterdiğini belirtmiştir. ChatGPT, belediyelerin yönetimindeki politikaların ve hizmetlerin genellikle belediye başkanının siyasi görüşleri ve partisinin ideolojisi doğrultusunda şekillendiğini söylemiştir. Gemini de farklılık gösterdiğini onaylamıştır. Her ikisi de bu farklılığın kaynaklanabileceği nedenleri açıklamıştır. ChatGPT ve Gemini'nin ortaya koyduğu nedenler Tablo 1'de gösterilmektedir.

Tablo 1. ChatGPT ve Gemini'ye göre Siyasi Partilerin Belediyeçilik Faaliyetleri Arasındaki Farklılıkların Nedenleri

ChatGPT	Başlık 3
Politikalar ve vizyon	Farklı ideolojiler ve öncelikler
Yatırım ve hizmet öncelikleri	Yerel koşullar
Kamu politikaları ve katılım	Parti içi farklılıklar
Yönetim tarzı ve bürokrasi	Kaynakların mevcudiyeti

ChatGPT'nin sunduğu nedenlerin detaylı açıklaması aşağıdaki gibi verilmiştir:

- **Politikalar ve Vizyon:** Farklı siyasi partilere ait belediyelerin, yönetim anlayışları ve politikaları farklı olabilir. Örneğin, sol görüşlü bir belediye başkanı sosyal hizmetlere ve eğitime daha fazla ağırlık verebilirken, sağ görüşlü bir belediye başkanı altyapı projelerine ve ekonomik büyümeye odaklanabilir.
- **Yatırım ve Hizmet Öncelikleri:** Farklı partilere ait belediyelerin, yatırım ve hizmet öncelikleri de değişebilir. Bir belediye, ulaşım ve altyapıya daha fazla yatırım yaparken, diğeri kültürel etkinliklere ve çevre projelerine daha fazla kaynak ayırabilir.
- **Kamu Politikaları ve Katılım:** Belediyelerin kamu politikaları, yönetimdeki siyasi partinin ideolojisi doğrultusunda şekillenir. Farklı partilere ait belediyeler, farklı düzeyde kamu katılımını teşvik edebilir veya farklı grupların ihtiyaçlarına odaklanabilir.
- **Yönetim Tarzı ve Bürokrasi:** Farklı siyasi partilere ait belediyelerin yönetim tarzları ve bürokratik yapısı da farklılık gösterebilir. Bu durum, belediyenin karar alma süreçlerini ve politikalarını etkileyebilir.

Gemini'nin sunduğu nedenlerin detaylı açıklaması aşağıdaki gibi verilmiştir:

- **Farklı İdeolojiler ve Öncelikler:** Farklı siyasi partiler, kentin nasıl yönetilmesi gerektiği konusunda farklı ideolojilere ve önceliklere sahip olabilir. Örneğin, bazı partiler toplu taşımaya ve sosyal hizmetlere daha fazla yatırım yapmayı tercih ederken, diğeri parklara ve yeşil alanlara daha fazla önem verme eğiliminde olabilir.
- **Yerel Koşullar:** Farklı şehirlerin ve kasabaların farklı ihtiyaçları ve öncelikleri vardır. Bu nedenle, bir belediyenin uygulamaları, o bölgenin özel koşullarına göre şekillenecektir.
- **Parti İçi Farklılıklar:** Aynı partinin farklı belediyeleri bile farklı yaklaşımlar benimseyebilir. Bu, belediye başkanının kişisel tercihlerine veya o bölgedeki parti üyelerinin görüşlerine bağlı olabilir.
- **Kaynakların Mevcudiyeti:** Bir belediyenin bütçesi ve kaynaklarının miktarı, sunabileceği hizmetlerin türünü ve kapsamını doğrudan etkileyecektir.

İki sohbet robotu da parti politikalarının ve önceliklerinin sergilenen belediyeçilik faaliyetleri arasındaki farklılığı açıklayabilecek nedenler olarak görmektedir. ChatGPT, kamu politikaları, katılım, yönetim tarzı ve bürokrasiyi diğer nedenler olarak değerlendirirken; Gemini parti içi farklılıklar ve kaynakların mevcudiyetini başlıca nedenler olarak görmektedir. Her iki sohbet robotu da nedenleri sıraladıktan sonra dinleyiciye uyarıda bulunmaktadır. ChatGPT, Türkiye’deki yerel yönetimlerin merkezi yönetim tarafından belirlenen yasal çerçeve içinde faaliyet gösterdiğini; dolayısıyla, belediyelerin politikalarının ve hizmetlerinin belirli sınırlar içinde olacağını ve bu sınırlar içinde farklı partilere göre çeşitlilik gösterebileceğini ifade etmektedir. Gemini ise son yıllarda belediyeçilikte bir homojenleşme eğilimi olduğunu belirtmekte ve bunun sebebini, merkezi hükümetin yetkilerini artırması ve belediyelerin üzerinde daha fazla kontrol sahibi olması olarak açıklamaktadır.

Sohbet robotları partilerin belediyeçilik faaliyetlerindeki farklılığı yapılan yatırımlar ve hizmet öncelikleri bağlamında ele almaktadır. Bu kapsamda, ChatGPT ve Gemini’nin siyasi partilerin belediyeçilik faaliyetlerinde gözlemlenen değişikliklerine yönelik notları Tablo 2’de ve Tablo 3’te verilmektedir. Her iki sohbet robotu da partiler arası farklılık sorulduğunda İyi Parti’yi (İP) analize dahil etmemiş; sadece Adalet ve Kalkınma Partisi (AKP), Cumhuriyet Halk Partisi (CHP), Milliyetçi Hareket Partisi (MHP) ve Halkların Demokratik Partisi (HDP) üzerinden karşılaştırma yapmıştır. Bu nedenle, İP’in belediyeçilik faaliyetlerindeki öncelikleri ayrıca sorulmuştur. Siyasi partilere göre belediyeçilik faaliyetlerindeki farklılıklar, sohbet robotlarına tekrar sorulduğunda Gemini İP’i analize dahil etmiş; ancak ChatGPT’nin analizinde İP yine yer almamıştır.

Tablo 2. ChatGPT’ye göre Siyasi Partilerin Yatırım ve Hizmet Öncelikleri

Siyasi Partiler	ChatGPT
AKP	Altyapı, ulaşım, sağlık ve eğitim; büyük ölçekli mega projeler; ekonomik büyüme ve istihdam için yerel iş dünyasını destekleme
CHP	Sosyal hizmetler, kültür-sanat etkinlikleri ve çevre koruma projeleri; kamusal alanların düzenlenmesi, yeşil alanların artırılması ve kentsel dönüşüm; eğitim ve sağlık hizmetlerinin yaygınlaştırılması
MHP	Güvenlik, toplumsal düzen ve milli değerlerin korunması; Kent güvenliği, trafik düzenlemeleri ve kamu düzeni; kültürel etkinlikler ve milli kimliğin ön plana çıkarılması
HDP	Yerel halkın katılımı; kültürel grupların hakları; kültürel etkinlikler ve azınlıkların kültürel hakları, yerel demokrasiyi güçlendirme; altyapı yatırımları; azınlıkların ihtiyaçlarını karşılayacak sosyal hizmetler ve programlar
İP	Kamu katılımını teşvik; adalet ve eşitlik; çevre koruma ve sürdürülebilir kalkınma; eğitim ve kültür hizmetleri, yerel ekonomiyi desteklemek; altyapı ve ulaşım

Tablo 3. Gemini'ye göre Siyasi Partilerin Yatırım ve Hizmet Öncelikleri

Siyasi Partiler	Gemini
AKP	Altyapı projeleri ve yatırımlar, özellikle yollar, köprüler ve binalar; sosyal hizmetlere ve muhafazakar değerlere odaklanma
CHP	Toplu taşıma, yeşil alanlar ve sosyal hizmetler; ayrıca, laiklik ve demokrasiye önem verme
MHP	Milliyetçilik ve güvenlik; yerel halka ve geleneklere önem verme
HDP	Kürt sorunu ve azınlık hakları; ekolojik denge ve katılımcı demokrasi
İP	Şeffaflık ve hesap verebilirlik, katılımcı demokrasi, yerel kalkınma, sosyal hizmetler, çevre koruma ve liyakat

İki uygulama da partiler arası farklılıkları açıkladıktan sonra belediye yönetimlerinin önceliklerinin belli ölçüde Tablo 2’de verilen genel politikalardan etkilendiğini; ancak her belediyenin kendi ihtiyaçlarına ve koşullarına göre önceliklerini belirlediğini dinleyiciye not olarak düşmektedir. Gemini bu nota ek olarak bir belediyenin uygulamaları hakkında daha fazla bilgi edinmek için o belediyenin internet sayfasının ziyaret edebileceğini veya yetkililerle iletişime geçilebileceğini ifade etmektedir.

Son olarak, sohbet robotlarına siyasi partilere göre farklılık gösteren belediyecilik faaliyetlerinin sınıflandırmasını hangi esaslara dayanarak yaptığı sorulmuştur. ChatGPT, sınıflandırmayı yaparken Türkiye’deki önemli siyasi partilerin genel politika önceliklerine ve belediyecilik alanında genellikle hangi alanlara odaklandıklarına göre hareket ettiğini belirtmiştir. Her siyasi partinin, belirli bir ideoloji ve politika platformu etrafında örgütlendiğini ve bu ideoloji ve politika platformunun, partinin yerel yönetimlerde de izlediği politikaları belirlediğini ifade etmiştir.

Gemini ise sınıflandırmayı yaparken belirli kaynaklardan faydalandığını söylemiştir. Bu kaynaklar arasında siyasi partilerin programları ve manifesti, belediyelerin web siteleri ve faaliyet raporları, medya haberleri ve analizler, akademik araştırmalar ve kişisel gözlemler ve deneyimler yer almaktadır. Ayrıca, sınıflandırmayı yaparken dikkate aldığı bazı özel noktalar olduğunu belirtmiştir. Bu noktaları altyapı projelerine ve yatırımlara verilen önem, toplu taşıma, yeşil alanlar ve sosyal hizmetlere verilen önem, laiklik ve demokrasiye verilen önem, milliyetçilik ve güvenliğe verilen önem, Kürt sorununa ve azınlık haklarına verilen önem, ekolojik dengeye ve katılımcı demokrasiye verilen önem olarak maddelendirmektedir. Ek olarak, bu sınıflandırmayı yaparken her partinin tüm belediyelerini tek bir kategoriye koymak zorunda olmadığını belirtmiştir. Her partinin farklı belediyelerinin farklı yaklaşımlar benimseyebileceğini hatırlatmıştır. Gemini ayrıca daha fazla bilgi edinmek için siyasi partilerin programlarını ve manifestolarının, belediyelerin web sitelerinin ve faaliyet raporlarının, medyada yer alan haberlerin ve analizlerin, akademik araştırmaların ve belirli şehirde veya kasabada farklı partilerin belediyecilik anlayışının incelenmesini önermiştir.

IV. TARTIŞMA

Sohbet robotlarının ikisi de Türkiye’de belediyecilik faaliyetlerinin siyasi partilere göre farklılık gösterdiğini onaylamaktadır. Bu bağlamda, ChatGPT ve Gemini çıktıları arasında tutarlılık bulunmaktadır. Ancak; söz konusu farklılığın altında yatan nedenler konusunda “politika ve öncelikler” başlığı dışında sohbet robotlarının yaklaşımı birbirinden farklıdır. ChatGPT, birbirine benzeyen hatta iç içe geçmiş nedenler belirlemiştir. Çoğunlukla düşünsel ve idari değişkenlere odaklanmıştır. Buna karşılık, Gemini yerel koşullar ve kaynakların yeterliliği gibi dış etmenleri de göz önünde bulundurmıştır. Yöneticilerin kişisel özelliklerinin de belediye faaliyetlerine yansiyabileceğini ifade etmiştir. Ayrıca, Gemini son yıllarda belediyeciliğin evrimi hakkında da bilgi vermiştir. Merkezi hükümetin artan yetkileri ve kontrolü nedeniyle belediyecilikte gözlemlenen homojenleşme nedeniyle belediyeler arasındaki farklılıklarda azalmaya dikkat çekmiştir. Buradan hareketle, ilk karşılaştırmada kapsam ve çeşitlilik bakımından Gemini’nin performansının daha iyi olduğunu söylemek mümkündür.

İkinci soruya gelindiğinde ise ilkinin aksine ChatGPT'nin daha kapsamlı bir analiz yaptığı görülmektedir. Siyasi partilerin yerel yönetimlerde yatırım ve hizmet önceliklerine yönelik, ChatGPT daha detaylı bir liste ortaya koymuştur. Ancak, her parti için belirlenen yatırım önceliklerinin ChatGPT'nin listesinde sayıca fazla olması, o listenin daha doğru olduğu anlamına gelmemektedir. Çünkü sonuçların tek bir partiye ait tüm belediyelere genellenebilirliği belirsizdir. Bir belediyenin gerçekleştirmiş olduğu bir proje bile robotun girdisinde yer aldığı takdirde; söz konusu projenin benzeri aynı partinin diğer belediyelerinde görülme bile listeye o proje de eklenmiş olabilir. Bu muğlaklığın giderilmesi için sohbet robotlarından elde edilen çıktıların gerçek örneklerle karşılaştırılması alana önemli bir fayda sağlayacaktır.

Her iki sohbet robotunun da siyasi partilerin yerel yönetimlerdeki önceliklerini örneklendirirken İP'i analize dahil etmesinin çeşitli nedenleri olabilir. Öncelikle, eğitim verilerinin eksik, güncelliğini yitirmiş veya önyargılı olmasından kaynaklanabilir. Ayrıca sohbet robotlarının soruları ve yanıtları yorumlaması bazen kusurlu veya yanlış olabilir. Sohbet robotları cevaplarını devasa veri üzerinden verse de robotların hâlâ erişemediği bazı bilgiler bulunmaktadır. Bu nedenle niş konular hakkında iyi cevaplar veremeyebilir. Farklı alanlardaki son gelişmelerden de haberdar olmayabilir. İpek ve arkadaşları, ChatGPT'nin eğitimdeki potansiyel etkilerini incelediği çalışmalarında, ChatGPT'nin yanlış cevaplar üretmek ve 2021 sonrasındaki olaylar hakkında sınırlı bilgiye sahip olmak gibi sınırlılıkları olduğunu tespit etmiştir [6]. Bu sorunu çözmek için kullanıcıların yanıtları eleştirel bir şekilde inceleyip düzenlemesi gerekebilir. Gemini ilk analizde İP'in belediye faaliyetlerine değinme de aynı soru ikinci kez yöneltildiğinde İP'i de başlıca siyasi partiler arasına dahil etmiştir. Bu durum bir yandan Gemini'nin öğrenme yeteneğine vurgu yapsa da diğer yandan sohbet robotlarının aynı soruya her zaman aynı cevabı vermeyeceğini göstermektedir. Dolayısıyla, ister ayrı bir yazar olarak ister veri kaynağı olarak değerlendirilsin; sohbet robotlarının bilimsel araştırmalarda kullanılmasının hala etik kaygılar içerdiği söylenebilir.

Siyasi partiler arasındaki farklılıkları başlıca başlıklar altında özetleyen sohbet robotları, bu başlıkların belediyelere göre değişebileceğini belirtmiştir. Başka bir deyişle, başlıkların hepsinin her belediye için geçerli olmayacağı anlamı çıkarılmaktadır. Yalnızca Gemini belediye uygulamaları hakkında daha detaylı bilginin belediyelerin web siteleri veya yetkilileri tarafından temin edilebileceğini söylemiştir. Bu yönlendirme, bir bakıma Gemini'nin kendisinin de eksik veya yanlış bilgi verme ihtimalini göz önünde bulundurduğu olarak yorumlanabilir.

Belediye faaliyetleri arasındaki farklılıkları sınıflandırırken nasıl bir yol izlendiğine dair Gemini daha açıklayıcı yanıt vermiştir. Taradığı kaynakları açıkça belirterek aslında dinleyicinin çıktılarını doğruluğunu test edebileceği araçları da göstermiştir. ChatGPT ise cevabında tekrara düşerek farklılıkların kaynaklanacağı nedenleri yinelemiştir. Önceden verdiği cevabı başka sözcüklerle yeniden ifade etmiştir. ChatGPT'ye detaylı bir şekilde sınıflandırmayı yaparken hangi kaynaklardan faydalandığı sorulduğunda ise Gemini ile benzer kaynaklara atıfta bulunmuştur. Buradan anlaşılacağı üzere, Gemini'nin yüzeysel soruları algılama performansı daha yüksektir. ChatGPT'nin açıkça yönlendirilmesi gerekmektedir. Bu nedenle, girdi kalitesi daha fazla önem kazanmaktadır. Alandaki araştırmalar, ChatGPT gibi modellerin fiziksel ve sosyal dünyaya dair tam bir anlayışa veya kavramlar ve varlıklar arasındaki bağlantılar hakkında akıl yürütme yeteneğine olmadığını; yalnızca eğitim sırasında öğrendikleri kalıplara göre metin üretebildiklerini belirtmektedir [7].

V. SONUÇLAR

Sonuç olarak, bu keşifsel çalışma, sohbet robotlarının dil geliştirme, yeniden ifade etme/başka sözcüklerle anlatma ve kavramsallaştırma gibi görevlerde bilimsel yazma asistanı olarak yararlı bir araç olma potansiyeline sahip olmalarına rağmen, an itibarıyla bilimsel yazar veya veri kaynağı olarak kullanılmasının doğru olmadığını ortaya koymaktadır.

Nitel araştırma yaparken, ChatGPT ve Gemini'de hatalı ve/veya eksik veri alımı bulunmaktadır. Buna ek olarak ChatGPT'de göze çarpan bir sentez eksikliği vardır. ChatGPT, bilgileri sentezlemek yerine büyük ölçüde rastgele verileri raporlamaya odaklanmaktadır. Gemini sentezleme konusunda ChatGPT'ye göre daha başarılı olmasına karşın; veri eksikliği kendisine hatırlatıldıktan sonra aynı soruya ekşiği tamamlayarak cevap vermesi, benzer sorulara farklı cevaplar verme sorunsalını ortaya çıkarmaktadır.

Arařtırmacılar sohbet robotları tarafından oluřturulan sonuları yorumlarken dikkatli olmalı ve diēer kaynakları kullanarak bilgileri doērulamalıdır. Sohbet robotlarının gerek zamanlı veri iyileřtirme yeteneklerinin ve veri analizi tekniklerinin arařtırmanın gvenilirliēini, doēruluēunu ve tutarlılıēını saēlamak iin daha fazla iyileřtirilmesi ve doērulanması gerekmektedir.

KAYNAKLAR

- [1] Aydın, ., & Karaarslan, E., “Is ChatGPT leading generative AI? What is beyond expectations?.” *Academic Platform Journal of Engineering and Smart Systems*, vol. 11, no. 3, pp. 118-134, 2023.
- [2] Dowling, M., & Lucey, B., “ChatGPT for (finance) research: The Bananarama conjecture.” *Finance Research Letters*, vol. 53, 103662, 2023.
- [3] Farhat, F., Sohail, S. S., & Madsen, D.O., “How trustworthy is ChatGPT? The case of bibliometric analyses.” *Cogent Engineering*, vol. 10, 2222988, 2023.
- [4] Kitamura, F. C., “ChatGPT is shaping the future of medical writing but still requires human judgment.” *Radiology*, vol. 307, no. 2, 230171, 2023.
- [5] Salvagno, M., ChatGPT Taccone, F. S., & Gerli, A. G., “Can artificial intelligence help for scientific writing?” *Critical Care*, vol. 27, no. 1, 75, 2023.
- [6] İpek, Z. H., Gzm, A. İ. C., Papadakis, S., & Kallogiannakis, M., “Educational Applications of the ChatGPT AI System: A Systematic Review Research.” *Educational Process: International Journal*, vol. 12, no. 3, pp. 26-55, 2023.
- [7] A. Borji. (2023). A categorical archive of ChatGPT failures. [Online]. Available: <https://arxiv.org/pdf/2302.03494.pdf>.



Integral SMC with Disturbance Observer for Altitude Control of a UAV Quadcopter

Rabia Taseen^{*}, Inam Ul Hasan Shaikh² and Ahsan Ali³

¹Department of Electrical Engineering, University of Engineering and Technology Taxila, Pakistan

¹Department of Electrical Engineering, University of Engineering and Technology Taxila, Pakistan

¹Department of Electrical Engineering, University of Engineering and Technology Taxila, Pakistan

*Rabia.Taseen@students.uettaxila.edu.pk

Abstract –This paper proposes an integral sliding mode control with disturbance observer (ISMC-DOB) based method for altitude control of a six-degree-of-freedom (6-DOF) unmanned aerial vehicle (UAV) quadcopter. We start by outlining the quadcopter's mathematical model. The quadcopter's altitude is then maintained while tracking the desired outputs using a nonlinear controller. It has been demonstrated that ISMC-DOB eliminates altitude tracking errors even in the presence of outside disturbances. The proposed method is demonstrated on a six-DOF MATLAB model.

Keywords – Integral Sliding Mode Controller (ISMC), Disturbance Observer (DOB), Degree Of Freedom (DOF), Unmanned Aerial Vehicle (UAV), Linear Quadratic Regulator (LQR).

I. INTRODUCTION

Although a lot of controllers for controlling UAVs have previously been developed, more controllers are still required, particularly ones that can function well in the face of external disturbances like wind. Additionally, these controllers must demonstrate their ability to navigate through congested urban regions. It is imperative to minimize overshooting and achieve a rapid rise time as well as a rapid settling time. This research's main goal is to progress flight control technology, which will enable more precise and trustworthy trajectory monitoring and increase UAV capabilities.

PID (Proportional Integral Derivative) control has been around for greater than a century, but it's still the most popular method for controlling drones. Its widespread use is due to its simple, dependable, and easily customizable features. PID controllers may, however, perform less than optimum under circumstances including highly coupled nonlinear dynamics, external disturbances, and high-frequency noise [1]. Many researchers have modified and evaluated using conventional PID controllers [2][3]. While [4] presents an adaptive digital PID control system intended to handle dynamical uncertainty, Article [5] suggests using a fuzzy PID method. Additionally, [6] enhances controller robustness in the face of wind-related interruptions by implementing a cascade PID attitude control in the drone's inner-loop control mechanism.

The application of LQR control is widespread in the field of drone flight. It is acknowledged that the best way to manage a linear system with quadratic performance indicators is through LQR. The relationship between the system's state and the LQR control law is inherently linear [7]. Additionally, [8] presents an iterative thrust-mixing system using the LQR control approach, as well as a unique body-rate controller. This innovation is anticipated to improve tracking efficiency and resilience to disturbances.

Recursive design techniques that work with both linear and nonlinear systems include back-stepping. The underlying concept involves constructing the feedback controller through the recursive development of the system's Lyapunov function. In order to confine the Lyapunov function along the trajectories of the closed-loop system, it is imperative to select a suitable control rule [9]. Another viable alternative is the

implementation of SMC. SMC's basic idea is to use the sliding mode controller to force the system state to converge from outside the hyperplane to the switching hyperplane. This is accomplished by modeling the switching hyperplane's design, also known as the sliding mode surface, on the system's dynamic properties [10]. Sliding mode control demonstrates efficacy in governing nonlinear systems and adeptly addresses system uncertainties. Noteworthy attributes encompass a straightforward algorithm, rapid response times, and robust resilience to external disturbances [3].

Neural network control is another method for controlling drone flight. The acquisition of intelligent control strategies developed by combining control theory and neural network theory is the basis of neural network control [11]. The method uses a parallel distributed technique to manage difficult to model and regulate non-linear and unpredictable control systems. Currently, data fitting and prediction are the main applications for this system, with very little usage in actual aircraft control [12].

Although many controllers have been created for the control of UAVs, there is still a need for controllers that work effectively when there are external disturbances like the wind. The controller also needs to be able to maneuver in confined spaces when operating in urban environments. For the latter purpose, it is necessary to have little overshoot, a rapid rise time, and a rapid settling time. To improve the UAVs' current capabilities, the project aims to develop flight control technology with accurate and reliable trajectory tracking.

When formulating a control problem, a mathematical model developed for controller design differs from the real plant. Unknown wind disturbances might have an unfavorable effect on quadcopter's ability to fly during crucial missions. The development of a flexible controller that guarantees satisfactory flight efficiency under adverse conditions is still challenging.

This effort aims to create an ISMC for a quadcopter. An ISMC with DOB manages the quadcopter's altitude or vertical motion. This controller can stabilize our plant in the presence of numerous environmental disturbances. The DOB technique has several benefits that enhance performance and stability e.g., air turbulence, wind gusts, and other uncontrollable environmental conditions are only a few of the external disturbances that quadcopters are susceptible to. With the DOB technique, disturbances may be precisely estimated and compensated for.

II. PRELIMINARIES

A. Euler Angles and Coordinate Systems

Quadcopters have a simple structure, and a wide range of flight and movement capabilities, including vertical take-off, landing, and hovering flight. A quadcopter has four rotors on it. Since each rotor has its speed, the rotors can change speeds uniformly, resulting in the desired thrust and accelerations. The six degrees of freedom (DOF) system used by Quadcopters allows them to spin on the aircraft's body axis, defining roll, pitch, and yaw angles, as well as move along the three spatial axes of X, Y, and Z. Movement is also produced along the Y and X axes by roll and pitch operations [14]. The four electric motors are responsible for the rotor thrust ("F"). The quadcopter needs to be lifted by the necessary thrust. To the rotors adjacent to it, each rotor rotates in the opposite direction. As seen in Fig. 3, rotors 1 and 3 rotate in the opposite direction, or clockwise, while rotors 2 and 4 rotate in the opposite direction, or anticlockwise. When constructing quadrotor controllers, the North, East, and Down reference frame is frequently utilized as the global coordinate system, and roll, pitch, and yaw angles are represented as Euler angles (φ , θ , ψ). The coordinate systems of the quadrotor are shown in Fig. 1 [13].

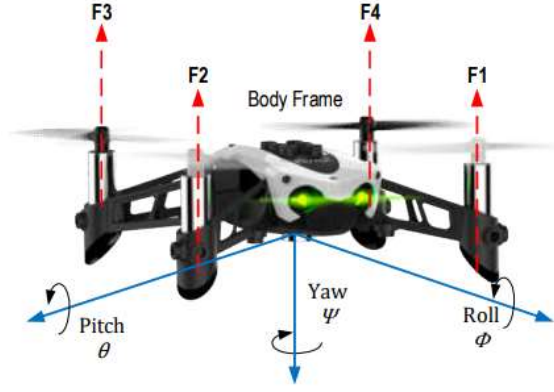

Fig. 1: Quadcopter-Mini Drone UAV [15]

B. Rotation Matrix

From previously specified global coordinate system to the quadcopter's body frame, Matrix forms can be used to express trigonometric equations later on. By rotating the other two body frame axes, we may similarly obtain two more matrices. The rotation of the b_1 , b_2 , and b_3 three-body frame axes with respect to the appropriate inertial frame axis, inertial trigonometric function equations, and their matrix representations are displayed in Fig. 2.

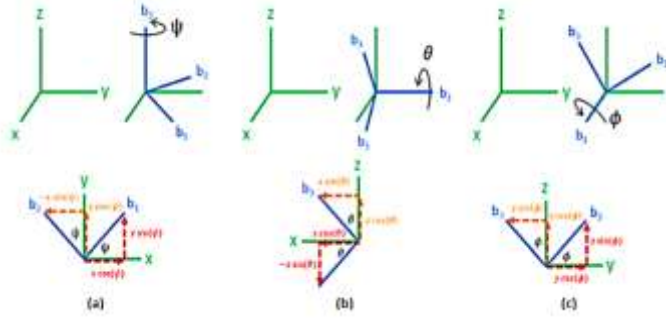

Fig. 2: Representation of Euler's Angles [16]

.For Yaw Fig. 2 (a), for Roll Fig. 2 (b) and for Pitch Fig. 2 (c) we have,

$$\begin{bmatrix} b_1 \\ b_2 \\ b_3 \end{bmatrix} = \begin{bmatrix} \cos\psi & \sin\psi & 0 \\ -\sin\psi & \cos\psi & 0 \\ 0 & 0 & 1 \end{bmatrix} \begin{bmatrix} x \\ y \\ z \end{bmatrix} \quad (1)$$

$$\begin{bmatrix} b_1 \\ b_2 \\ b_3 \end{bmatrix} = \begin{bmatrix} \cos\theta & 0 & -\sin\theta \\ 0 & 1 & 0 \\ \sin\theta & 0 & \cos\theta \end{bmatrix} \begin{bmatrix} x \\ y \\ z \end{bmatrix} \quad (2)$$

$$\begin{bmatrix} b_1 \\ b_2 \\ b_3 \end{bmatrix} = \begin{bmatrix} 1 & 0 & 0 \\ 0 & \cos\phi & \sin\phi \\ 0 & -\sin\phi & \cos\phi \end{bmatrix} \begin{bmatrix} x \\ y \\ z \end{bmatrix} \quad (3)$$

The matrix for the inertial to body frame transition is obtained by the orderly combination of these three matrices Fig. 2. The order in which things are done is essential.

$$\begin{bmatrix} b_1 \\ b_2 \\ b_3 \end{bmatrix} = \begin{bmatrix} c\psi & s\psi & 0 \\ -s\psi & c\psi & 0 \\ 0 & 0 & 1 \end{bmatrix} \begin{bmatrix} c\theta & 0 & -s\theta \\ 0 & 1 & 0 \\ s\theta & 0 & c\theta \end{bmatrix} \begin{bmatrix} 1 & 0 & 0 \\ 0 & c\phi & s\phi \\ 0 & -s\phi & c\phi \end{bmatrix} \begin{bmatrix} x \\ y \\ z \end{bmatrix} \quad (4)$$

III. QUADCOPTER MODELLING

A. Kinematic Modelling

Let's first describe the kinematics in the body and inertial frames before delving into the physical science of quadcopter movement. I and \dot{I} represents the quadcopter's position and velocity within the inertial frames [17].

$$I = [x_i \ y_i \ z_i]^T \quad (5)$$

$$\dot{I} = [\dot{x}_i \ \dot{y}_i \ \dot{z}_i]^T \quad (6)$$

Similarly, the roll, pitch, and yaw angles of the body frame are described as.

$$v = [\phi \ \theta \ \psi]^T \quad (7)$$

$$\dot{v} = [\dot{\phi} \ \dot{\theta} \ \dot{\psi}]^T \quad (8)$$

A vector that travels along the spinning axis is called the angular velocity, and all that \dot{v} represents the time derivative of the roll, pitch, and yaw. We can use a specific equation to convert these angular velocities into the angular velocity vector [18]:

$$\omega = \begin{bmatrix} 1 & 0 & -\sin\theta \\ 0 & \cos\phi & \cos\theta\sin\phi \\ 0 & -\sin\phi & \cos\theta\cos\phi \end{bmatrix} \dot{v} \quad (9)$$

ω represents the angular velocity vector in the body frame.

We are able to associate the inertial and body frames thanks to a rotation matrix R that translates the body frame to the inertial casing. By "fixing" the roll, pitch, and yaw consistently using the ZYZ Euler point rules, the matrix below is obtained from Eq. 4 by $X = [M^{-1}][b]$. Where $M^{-1} = \mathcal{R}$, $b = [b_1 \ b_2 \ b_3]^T$ and $X = [x \ y \ z]^T$

$$\mathcal{R} = \begin{bmatrix} c\phi c\psi - c\theta s\phi s\psi & -c\psi s\phi - c\phi c\theta s\psi & s\theta s\psi - s\theta \\ c\theta c\psi s\phi + c\phi s\psi & c\phi c\theta c\psi - s\phi s\psi & -c\psi s\theta \\ s\phi s\theta & c\phi s\theta & c\theta \end{bmatrix} \quad (10)$$

Where c represents cosine and s denotes the sine.

B. Dynamical Modelling

By varying the speed of rotation of motors 1, 2, 3, and 4, the quadcopter's thrust is used to adjust its height during its upward and downward flight. The quadcopter can roll by tilting to the left or right in order to do side manoeuvres. The ability of a quadcopter to go forward or backward by modifying its front or rear wing is referred to as pitch. Yaw refers to the quadcopter's capacity to rotate in either an anticlockwise or clockwise direction while maintaining level flight with the ground. The four motors' rotational rates will be adjusted to create these flying motions. [17].

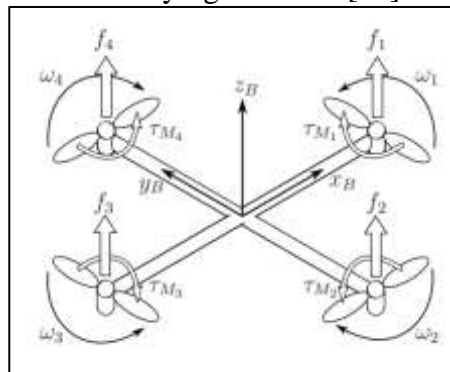

Fig. 3: The Body Frame of a Quadcopter [19]

We would also like to compute the torques now that we have calculated the forces on the quadcopter. With regard to the body's z-axis, each rotor adds a little torque. To keep the propeller spinning and

producing thrust, this torque displaces the frictional drag forces and produces the instantaneous angular acceleration. In fluid dynamics, the drag equation yields the frictional force. [20]:

$$D_F = \frac{1}{2} \rho C_D A v^2 \quad (11)$$

- D_F represents drag force,
- ρ is the air density,
- C_D denotes drag coefficient,
- A represents the quadcopter's blade area, and
- v is the speed of quadcopter's blade.

In general representation for drag force is [1],

$$D_F = \begin{bmatrix} A_x & 0 & 0 \\ 0 & A_y & 0 \\ 0 & 0 & A_z \end{bmatrix} \begin{bmatrix} \dot{x} \\ \dot{y} \\ \dot{z} \end{bmatrix} \quad (12)$$

Let, control inputs are given as follows [21].

$$u_1 = b(\omega_1^2 + \omega_2^2 + \omega_3^2 + \omega_4^2) \quad (13)$$

$$u_2 = lb(\omega_4^2 - \omega_2^2) \quad (14)$$

$$u_3 = lb(\omega_3^2 - \omega_1^2) \quad (15)$$

$$u_4 = d(\omega_4^2 + \omega_2^2 - \omega_3^2 - \omega_1^2) \quad (16)$$

u_1 is the control input for total thrust generated by the four propellers, $u_2, u_3,$ and u_4 shows the control input for total torque produced by roll, pitch and yaw.

Translational motion equations:

By evaluating Eq. (9) and Net force $F^B = [0 \ 0 \ T]^T$

T stands for the entire thrust.

$$\mathcal{R}F^B = \begin{bmatrix} T(s\theta c\phi c\psi + s\theta s\psi) \\ T(c\phi s\theta s\psi - s\theta c\psi) \\ T(c\phi c\theta) \end{bmatrix} \quad (17)$$

Gravitational force factor,

$$G = \begin{bmatrix} 0 \\ 0 \\ -g \end{bmatrix} \quad (18)$$

Currently, based on Newton's second law: Force = $m \times a$

From Eq. (11), Eq. (16) and (Eq. 17) we get Translational Matrix (T.M),

$$T.M = G + \mathcal{R}F^B/m - D_F/m \quad (19)$$

For our convenience we neglect the drag force for mathematical proof but at the end we take it as a coefficient in our simulation work.

$$\begin{bmatrix} \ddot{x} \\ \ddot{y} \\ \ddot{z} \end{bmatrix} = \begin{bmatrix} 0 \\ 0 \\ -g \end{bmatrix} + \begin{bmatrix} T(s\theta c\phi c\psi + s\theta s\psi) \\ T(c\phi s\theta s\psi - s\theta c\psi) \\ T(c\phi c\theta) \end{bmatrix} \frac{1}{m} \quad (20)$$

Angular Motion Equations:

In [22][23],

Net Moment = Inertia \times Angular acceleration + torque acting on body + Gyroscopic Forces (G.F)

$$I\dot{\Omega} = -\Omega \times (I.\Omega) + \tau_B + G.F \quad (21)$$

$$\Omega = [p \quad q \quad r]^T; \dot{\Omega} = [\dot{p} \quad \dot{q} \quad \dot{r}]^T \quad (22)$$

$$\tau_B = \begin{bmatrix} \tau_\phi \\ \tau_\theta \\ \tau_\varphi \end{bmatrix} \quad (23)$$

In yaw, there is no gyroscopic effect term because the reaction torque is essentially what causes the yawing moment and gyroscopic effect. The reaction torque is produced by the rotor revolution, and torque direction is exactly the opposite of the rotor rotation direction. A yaw moment can be eliminated by the opposing rotation of two rotors [24].

Moment of inertia matrix of quadcopter is,

$$I = \begin{bmatrix} I_{xx} & 0 & 0 \\ 0 & I_{yy} & 0 \\ 0 & 0 & I_{zz} \end{bmatrix} \quad (24)$$

By evaluating this term, $-\Omega \times (I \cdot \Omega)$ from Eq. (20)

$$-\Omega \times (I \cdot \Omega) = \begin{bmatrix} (I_{yy} - I_{zz})qr \\ (I_{zz} - I_{xx})rp \\ (I_{xx} - I_{yy})pq \end{bmatrix} \quad (25)$$

Following the manipulation of equations (16) through (19) and (20) through (24), the 6-DOF quadcopter UAV dynamics are provided as follows [25];

$$\ddot{x} = (\cos\phi \sin\theta \cos\psi + \sin\phi \sin\psi) \frac{u_1}{m} \quad (26)$$

$$\ddot{y} = (\cos\phi \sin\theta \cos\psi - \sin\phi \sin\psi) \frac{u_1}{m} \quad (27)$$

$$\ddot{z} = -g + (\cos\phi \cos\theta) \frac{u_1}{m} \quad (28)$$

$$\ddot{\phi} = a_1 \dot{\theta} \dot{\psi} + a_2 \dot{\theta} \Omega_d + \frac{1}{I_x} u_2 \quad (29)$$

$$\ddot{\theta} = a_3 \dot{\phi} \dot{\psi} + a_4 \dot{\phi} \Omega_d + \frac{1}{I_y} u_3 \quad (30)$$

$$\ddot{\psi} = a_5 \dot{\phi} \dot{\theta} + \frac{1}{I_z} u_4 \quad (31)$$

Where;

$$a_1 = \frac{I_{yy} - I_{zz}}{I_{xx}}, a_2 = \frac{J_r}{I_{xx}}, a_3 = \frac{I_{zz} - I_{xx}}{I_{yy}}, a_4 = \frac{J_r}{I_{yy}}, \text{ and } a_5 = \frac{I_{xx} - I_{yy}}{I_{zz}}$$

IV. CONTROLLER DESIGN

A. Integral Sliding Mode Controller

One kind of variable structure control is SMC. The state-space of the closed-loop system frequently has a variety of structures at different places. Desired performance is achieved by creating particular rules to redistribute control efforts across isolated structures, even though these structures may be unstable. This results in a closed-loop system with distinct properties, independent of the properties of the divided structures [18]. In a quadcopter, an integral SMC is a control scheme that blends SMC and integral control methods. It is intended to improve the quadcopter's performance, stability, and capacity to reject disturbances. The Integral SMC's integral control component integrates the error signal gradually in order to get rid of steady-state errors and raise the quadcopter's tracking accuracy. When handling outside

disruptions or uncertainties that may alter the quadcopter's position or attitude, this is especially helpful [13][26].

$$u(t) = -k \times s(t) - c \times \int s(t)dt \quad (32)$$

- $u(t)$ symbolizes the input for control.
- $k, s(t)$ are the sliding variable between the system state and reference state and the sliding mode control gain. c is the integral control gain.
- $\int s(t)dt$ symbolizes the sliding variable's integral.

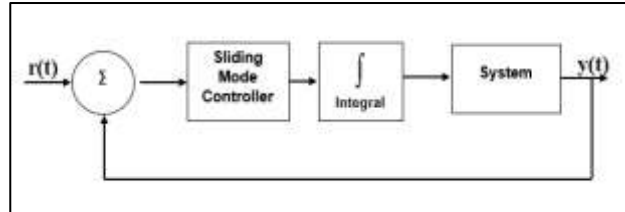

Fig. 4: Schematic of Integral SMC [13]

B. Disturbance Observer

In a quadcopter, the disturbance observer methodology is a way to assess and account for outside disturbances or uncertainties that impact the dynamics of the system. It is employed to enhance the robustness and disturbance rejection capabilities of the quadcopter's control system [18][15].

$$u(t) = F(t) + L \times \partial(t) \quad (33)$$

- $u(t)$ symbolizes the input for control.
- $F(t)$ is feedback control signal.
- L gain matrix.
- $\partial(t)$ is estimated disturbance.

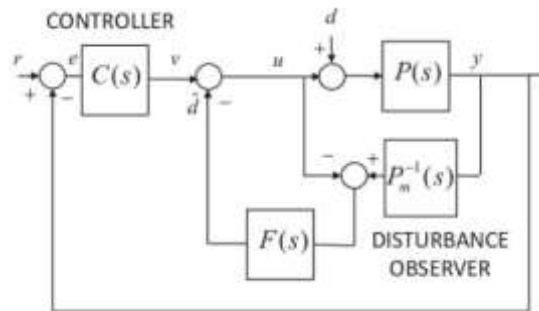

Fig. 5: Schematic of Disturbance Observer [15]

C. ISMC with Disturbance Observer for Altitude Control

The core idea of ISMC is the addition of an integral term to the sliding manifold [27]. By removing the reaching phase and allowing the system is configured to start in the initial state on the sliding manifold, this integral term ensures the system's overall robustness. Additionally noticeable is the chattering effect, which lowers system performance. As a result, a lot of researchers have been focusing on that problem. The ISMC controller has been used to remove the steady-state error. Below is a block diagram of proposed research,

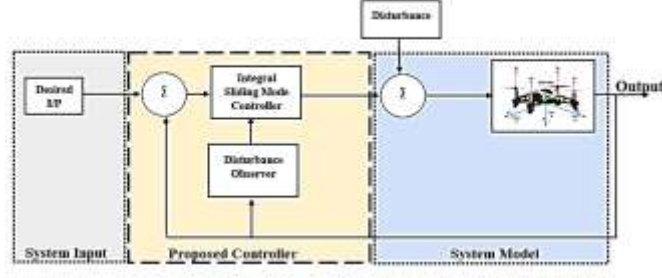

Fig. 6: Basic Control Block Diagram for Quadcopter

Quadrotor's altitude dynamics are given.

$$\ddot{z} = -g + (\cos\phi\cos\theta) \frac{u_1}{m} + \mu_z \quad (34)$$

Where, μ_z is the disturbance and,

$$u_1 = b(\Omega_1^2 + \Omega_2^2 + \Omega_3^2 + \Omega_4^2) \quad (35)$$

Error of the quadcopter altitude is,

$$e_z = e - e_z \quad (36)$$

Sliding surface for the altitude is,

$$s_z = \dot{e}_z + k_1 e_z + k_2 \int_0^t e_z dt \quad (37)$$

Where $k_1, k_2 > 0$ are the control gains. According to sliding mode condition,

$$\dot{s}_z = u_z + \mu_z - \ddot{z}_d + k_1 \dot{e}_z + k_2 e_z \quad (38)$$

Where u_z is the virtual control and defined as,

$$u_z = \ddot{z}_d - k_1 \dot{e}_z - k_2 e_z + u_1 \quad (39)$$

$$\dot{s}_z = \mu_z + u_1 \quad (40)$$

For μ_z estimation we assume the Lyapunov function as,

$$V_z = \frac{1}{2} s_z^2 + \frac{1}{2} \tilde{\mu}_z \gamma_z \tilde{\mu}_z \quad (41)$$

Where $\tilde{\mu}_z$ is the uncertainty error and γ_z is the positive constant.

$$\dot{V}_z = s_z \dot{s}_z + \tilde{\mu}_z \gamma_z \dot{\tilde{\mu}}_z \quad (42)$$

The disturbance estimation law is given as,

$$\dot{\hat{\mu}}_z = \frac{1}{\gamma_z} s_z \quad (43)$$

Finally the control laws is,

$$u_1 = -\hat{\mu}_z - K_1 \text{sgn}(s_z) - K_2 s_z \quad (44)$$

Where K_1, K_2 are the positive gains.

V. RESULTS AND DISCUSSION

A. Step Input by using the PID controller

The altitude response of the applied PID controller is summarized in Table 1 and is displayed in Fig. 7. When a step input of 2 m is given, the response has a 20% overrun; the rise and settling times are 0.58 and 7.29 seconds, respectively. The reference signal is shown by the dotted line, while the actual response is shown by the blue line.

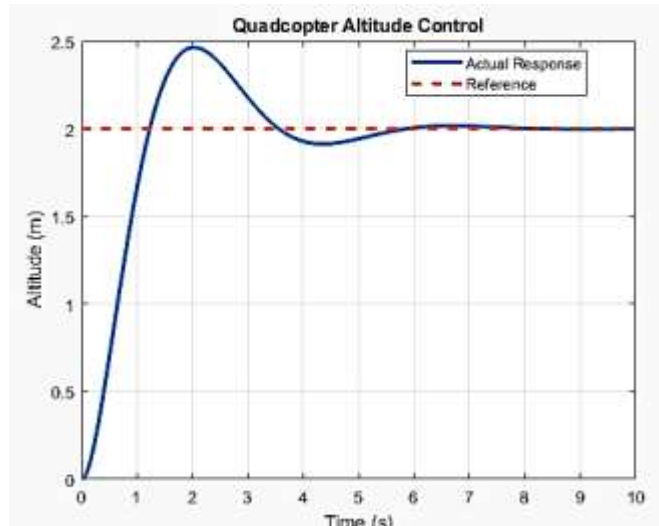

Fig. 7: Altitude Response of PID Controller

Table 1. Results of Altitude Response of PID Controller

Description	Value
Rise Time	0.58 s
%-Overshoot	20%
Settling Time	7.29 s

B. Step Input by using the PID controller by Ziegler-Nichols method

The Ziegler-Nichols method altitude response for the PID controller is shown in Fig. 8 and is also included in Table 2. When a 2 m step input is given, the response has a 15% percentage overrun; the rise and settling times are 0.59 and 6.34 s, respectively. The blue line represents the actual reaction, and the dotted line represents the reference signal.

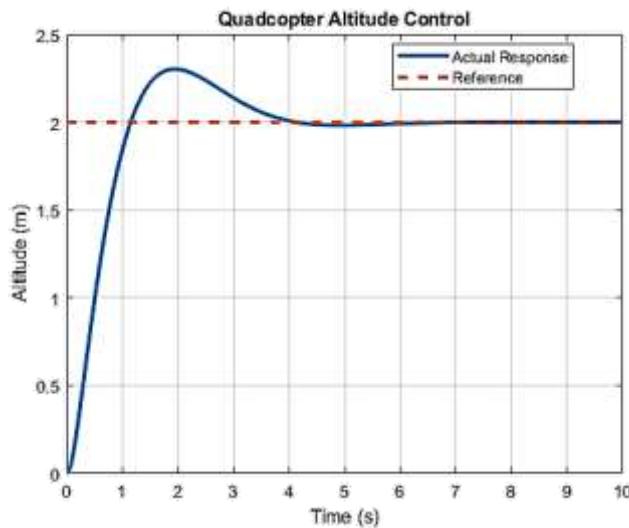

Fig. 8: Altitude Response of PID by using the Ziegler-Nichols Method

Table 2. Results of Altitude Response of PID by using the Ziegler-Nichols Method

Description	Value
Rise Time	0.59 s
%-Overshoot	15%
Settling Time	6.34 s

C. Step Input by using the SMC-PID controller

The altitude response of the implemented SMC-PID controller is summarized in Table 3 and is displayed in Fig. 9. For a step input of 2 m, the response has a percentage overrun of 21.66%. 2.69 seconds is the settling time and 0.45 seconds is the rising time. The reference signal is shown by the dotted line, while the actual response is shown by the blue line.

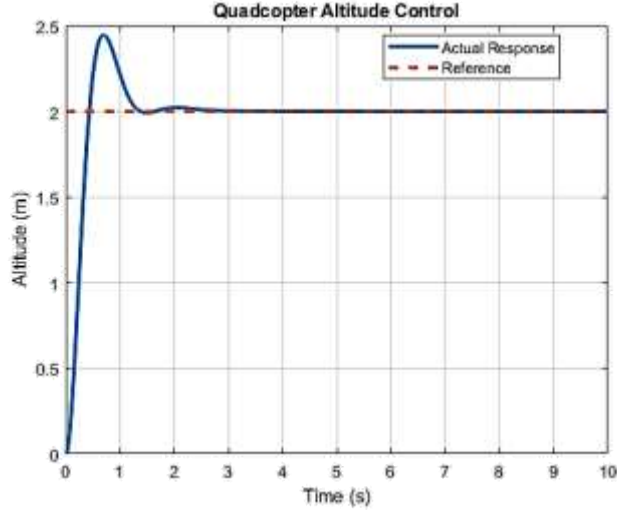

Fig. 9: Altitude Response of SMC-PID Controller

Table 3. Results of Altitude Response of SMC-PID Controller

Description	Value
Rise Time	0.30 s
%-Overshoot	21.66%
Settling Time	2.69 s

D. Step Input by using the ISMC with Disturbance Observer

The altitude response of the ISMC with the Disturbance Observer applied is displayed in Fig. 10, and a summary of the data is given in Table 4. If a step input of 2 m is given, the response has a percentage overrun of 3%. There has been a rising of 0.59 seconds and a settling of 2.1 seconds. The dotted line represents the reference signal, the orange line represents the applied disturbance, and the blue line represents the actual response.

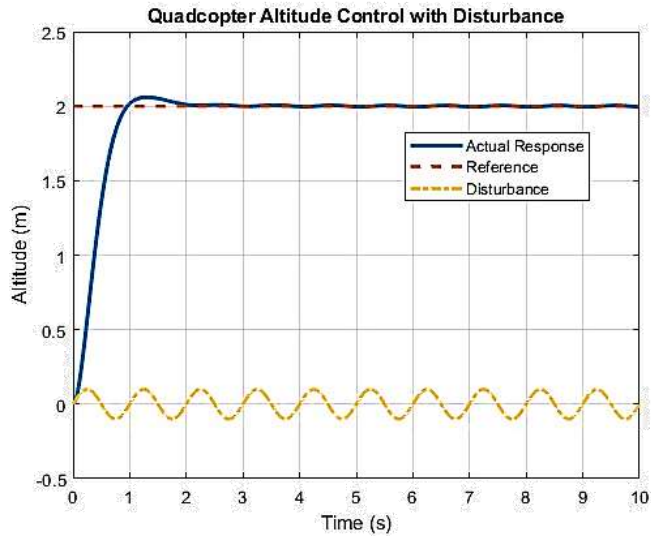

Fig. 10: Altitude Response of ISMC with DOB

Table 4. : Results of Altitude Response of ISMC with DOB

Description	Value
Rise Time	0.59 s
%-Overshoot	2.941%
Settling Time	2.1 s

An overview of the Altitude results is provided in Table 5. The data unambiguously demonstrate that the altitude overshooting performance of the ISMC with Disturbance Observer has improved, rising from 21.66% to 2.941%. The settling time is reduced from 7.29 s to 2.1 s for altitude. The altitude climb time has risen somewhat, from 0.30 to 0.59 seconds.

Table 5. Summary of Altitude Results with Step Input

Parameter	PID	PID -ZN	SMC -PID	ISMC- DOB	Improvement
Rise Time	0.5 8 s	0.5 9 s	0.30 s	0.59 s	Yes
%overshoot	20 %	15 %	21.6 6%	2.941 %	Yes
Settling Time	7.2 9 s	6.3 4 s	2.69 s	2.1 s	Yes

The data unequivocally demonstrate that the ISMC with disturbance observer has improved its performance in terms of overshoot and settling time with a small rise time increase. For flying in formation and course planning, this is a really helpful feature.

VI. CONCLUSION AND FUTURE WORK

This study compares the rise time, settling time, and % overshoot in simulations of PID, PID using Ziegler-Nichols technique, SMC-PID, and ISMC with Disturbance Observer. With a slight rise in rise time, the ISMC with DOB has enhanced its performance in terms of overshoot and settling time. This is a highly useful feature for course planning and formation flying. Additionally, a comparison of the simulated perturbations of ISMC and DOB with those of other controllers is given. The DOB controller has the ability to reject disturbances.

It is advised that numerous control parameters be adjusted for next work. For this, an appropriate optimization method can be created and put into practice. The application of fractional order sliding mode to the various UAV configurations is an additional factor. A smooth reaching phase can likewise be achieved by implementing a higher order sliding mode.

REFERENCES

- [1] S. Abdrhlay and A. Zakriti, "Modeling of a Quadcopter TrajectoryTracking System Using PID Controller", *The 12th International Conference Interdisciplinarity in Engineering, Procedia Manufacturing*, Elsevier, vol. 32, pp. 564-571, 2019.
- [2] X. Wang, "Sliding Mode Control Design with Disturbance Observer for a Quadrotor", *Thesis: The Department of Mechanical and Industrial Engineering, Northeastern University, Boston, Massachusetts*, August 2021.
- [3] Y. Jing, A. Mirza, R. Sipahi, and J. M. Lorenzo, "Sliding Mode Controller with Disturbance Observer for Quadcopters; Experiments with Dynamic Disturbances and in Turbulent Indoor Space," *Drones*, MDPI, vol. 7, no. 5, p. 328, 2023.
- [4] A. Goel, A. M. Salim, A. Ansari, S. Ravela, and D. Bernstein, "Adaptive Digital PID Control of a Quadcopter with Unknown Dynamics", *Journal of arXiv preprint arXiv:2006.00416*, 2020.
- [5] J. Dong and B. He, "Novel Fuzzy PID-Type Iterative Learning Control for Quadrotor", *Journal of Sensors*, MDPI, vol. 19, no. 1, pp. 24, 2018.
- [6] J. Zhou, R. Deng, Z. Shi, and Y. Zhong, "Robust cascade PID attitude control of quadcopter helicopters subject to wind disturbance", *2017 36th Chinese Control Conference (CCC)*, IEEE, pp. 6558-6563, 2017.
- [7] X. Wang, "Sliding Mode Control Design with Disturbance Observer for a Quadrotor", *Thesis: The Department of Mechanical and Industrial Engineering, Northeastern University, Boston, Massachusetts*, August 2021.
- [8] M. Faessler, D. Falanga, and D. Scaramuzza, "Thrust Mixing, Saturation, and Body-Rate Control for Accurate Aggressive Quadrotor Flight", *IEEE Robotics and Automation Letters*, IEEE, vol. 2, no. 2, pp. 476-482, 2016.

- [9] C. Ha, Z. Zuo, F. B. Choi, and D. Lee, "Passivity-based adaptive backstepping control of quadrotor-type UAVs", *Journal of Robotics and Autonomous Systems*, Elsevier, vol. 62, no. 9, pp. 1305-1315, 2014.
- [10] L. Besnard, Y. B. Shtessel, and B. Landrum, "Quadrotor vehicle control via sliding mode controller driven by sliding mode disturbance observer", *Journal of the Franklin Institute*, Elsevier, vol. 349, no. 2, pp. 658-684, 2012.
- [11] H. Voos, "Nonlinear and neural network-based control of a small four-rotor aerial robot", *2007 IEEE/ASME International Conference on Advanced Intelligent Mechatronics*, IEEE, pp. 1-6, 2007.
- [12] Y. Wei, G. Sun, S. Wang, and Y. Wei, "A Novel Four Rotor Aircraft Control Algorithm Based on the Optimized Fuzzy Neural Network", *2017 5th International Conference on Machinery, Materials and Computing Technology (ICMMCT 2017)*, Atlantis Press, pp. 580-586, 2017.
- [13] V. Artale, et al., "Dynamic analysis of a hexacopter controlled via LQR-PI," *AIP Conference Proceedings*, American Institute of Physics, vol. 1558. no. 1, 2013, pp. 1212-1215.
- [14] C. S. T. Daughtry and E. R. Hunt Jr., "What good are unmanned aircraft systems for agricultural remote sensing and precision agriculture?," *International Journal of Remote Sensing*, vol. 39, no. 15-16, pp. 5345-5376, 2018.
- [15] A. Noordin, M. A. Basri, and Z. Mohamed, "Position and Attitude Tracking of MAV Quadrotor Using SMC-Based Adaptive PID Controller," *Drones*, vol. 6, no. 9, p. 263, 2022.
- [16] M. Usman, "Quadcopter Modelling and Control with MATLAB/Simulink Implementation", *Thesis 2020, LAB University of Applied Sciences*, 2020.
- [17] A. Kareem and et.al., "Modeling and Nonlinear Control of a Quadcopter for Stabilization and Trajectory Tracking," *Journal of Engineering*, Hindawi, vol. 2022, pages 19, 2022.
- [18] M. Eatemadi, "Mathematical Dynamics, Kinematics Modeling and PID Equation controller of Quadcopter", *International Journal of Applied Operational Research*, vol. 7, issue no. 1, pp. 77-85, 2017.
- [19] T. Luukkonen, "Modelling and control of quadcopter," *Independent research project in applied mathematics*, Espoo, vol. 22, no. 22, 2011.
- [20] (2023) Quadcopter Dynamics and Simulation, Andrew Gibiansky, Available online at: <https://andrew.gibiansky.com/blog/physics/quadcopter-dynamics/>.
- [21] A. Kapnopoulos and A. Alexandridis, "A cooperative particle swarm optimization approach for tuning an MPC-based quadcopter trajectory tracking scheme", *Journal of Aerospace Science and Technology*, Elsevier, vol. 127, pp. 107725, 2022.
- [22] S. J. Haddadi, P. Zarafshan, and J. N. Farahnaz, "Dynamics modelling and implementation of an attitude control on an Octorotor," *2015 IEEE 28th Canadian Conference on Electrical and Computer Engineering (CCECE)*, IEEE, 2015, pp. 722-727.
- [23] R. Mahony et al., "Nonlinear dynamic modeling for high performance control of a quadrotor," *Australian Robotics and Automation Association*, 2012.
- [24] (2023) Quadcopter Dynamic Model: Propeller Gyroscopic Effect, MTwallets, Available online at: <https://www.mtwallets.com/quadrotor-dynamic-model-propeller-gyroscopic-effect/>, Accessed on 23 Decemeber 2023.
- [25] A. Eltayeb, and et al., "An Improved Design of an Adaptive Sliding Mode Controller for Chattering Attenuation and Trajectory Tracking of the Quadcopter UAV," *IEEE Access*, vol. 8, pp. 205968-205979, 2020.
- [26] M. W. Spong, "Underactuated Mechanical Systems," *Control Problems in Robotics and Automation*, Berlin, Heidelberg, Springer, 2005, pp. 135-150.
- [27] I. Ahmad, M. Liaquat, F. M. Malik, H. Ullah, and U. Ali, "Variants of the Sliding Mode Control in Presence of External Disturbance for Quadrotor", *IEEE Access: Open Access Journal*, vol. 8, pp. 227810-227824, 2020.



Teknoloji Şirketlerinin Birleşme ve Satın Alma İşlemlerinin Makine Öğrenmesi Yöntemleri ile Tahmini

Eray YILMAZ, M. Hanefi CALP

Yönetim Bilişim Sistemleri / İktisadi ve İdari Bilimler Fakültesi, Ankara Hacı Bayram Veli Üniversitesi, Türkiye

yilmaz.eray@hbv.edu.tr, hanefi.calp@hbv.edu.tr

Özet – Bu çalışmada, 2021 yılında önde gelen teknoloji şirketlerinin gerçekleştirdiği birleşme ve satın alma stratejileri makine öğrenmesi yöntemleri ile tahmin edilerek analiz edilmiştir. Çalışmada kullanılan veriseti, Microsoft, Google, IBM, HP, Apple, Amazon, Facebook, Twitter, eBay, Adobe, Citrix, Redhat, BlackBerry ve Disney gibi sektörde öncü konumda bulunan teknoloji şirketlerinin yürüttüğü satın alma işlemlerini içermektedir. Veriler Wikipedia, TechCrunch ve CrunchBase gibi güvenilir kaynaklardan derlenerek hazırlanmıştır. Bu noktada, her bir satın alma işleminin tarihi, yılı, ayı, satın alınan şirketin adı, satın alma maliyeti veya değeri, satın alınan iş kullanım senaryosu ve satın alma yapılan ülke gibi çeşitli öznitelikler bulunmaktadır. Bu öznitelikleri temel alarak Yapay Sinir Ağları, k-En Yakın Komşu, Destek Vektör Makineleri, Lojistik Regresyon, Rastgele Orman, Naive Bayes ve AdaBoost makine öğrenimi algoritmalarından yararlanılmıştır. Çalışmanın bulguları, analiz edilen veri setindeki eğilimleri ve önemli desenleri ortaya çıkarılarak 2021 yılında teknoloji sektöründeki birleşme ve satın alma aktivitelerinin genel bir resmini sunmaktadır. Çalışmanın, teknoloji şirketlerinin stratejik kararlarını anlamak, sektördeki rekabeti değerlendirmek ve gelecekteki gelişmeleri öngörmek isteyen araştırmacılar ve endüstri profesyonelleri için değerli bir kaynak niteliği taşıması beklenmektedir.

Anahtar Kelimeler – Makine Öğrenimi, Teknoloji Şirketi, Birleşme ve Satın Alma Stratejileri

I. GİRİŞ

Birleşme ve Satın Almalar (B&SA), yüksek teknoloji sektöründe şirketlerin teknolojik performansına olan etkisini anlamak amacıyla bir dizi önemli çalışmayı içermektedir. Bu yöndeki çalışmalar, farklı yönleriyle B&SA'ların teknolojik performansa olan etkisini ele alarak sektörlere önemli katkılarda bulunmuştur. Hagedoorn ve Duysters, çalışmalarında uluslararası bilgisayar endüstrisine odaklanarak, B&SA'ların birleşen şirketler arasındaki stratejik ve organizasyonel uyumunun teknolojik performansı nasıl iyileştirdiğini savunmaktadırlar [5].

Cloudt, Hagedoorn ve Van Kranenburg'ün araştırması, büyük yüksek teknoloji sektörlerindeki B&SA'ların sonrasındaki yenilikçi performansını incelemekte ve teknolojik olmayan B&SA'ların sonrasındaki yenilikçi performansı olumsuz etkilediğini vurgulamaktadır. Ayrıca, edinilen bilgi tabanının büyüklüğünün ve ilgili olup olmadığının inovasyon üzerinde kritik roller oynadığını göstermektedir [6]. Hagedoorn ve Sadowski, stratejik teknoloji ittifaklarından B&SA'ya geçiş üzerine odaklanarak, ittifaklar ve B&SA'ların farklı yönetim modları olduğunu belirterek nadir bir geçiş sürecine odaklanmaktadır [4].

Weber ve Tarba'nın vaka çalışması, kültür çatışmalarının sonrasındaki birleşme entegrasyon sorunlarını vurgulayarak Alman FAST'ın İsrail şirketi Aladdin tarafından satın alınması örneğini sunmaktadır [9]. Bena ve Li'nin patent-B&SA veri seti kullanarak yaptığı araştırma, büyük patent portföyüne sahip ve düşük Ar-Ge harcamaları olan şirketlerin satın alıcı, yüksek Ar-Ge harcamalarına sahip ve patent

üretiminde yavaş büyüyen şirketlerin hedef olduğunu göstermekte ve inovasyon yeteneklerini birleştirerek elde edilen sinerjilerin satın almaların önemli sürücülerini olduğunu vurgulamaktadır [7]. Danzon, Epstein ve Nicholson'un çalışması, farmasötik/biyoteknoloji endüstrisindeki B&SA etkinliğini inceleyerek, büyük şirketler için birleşmelerin genellikle patent sürelerinin dolmasına ve ürün yelpazesinde boşluklara tepki olarak gerçekleştiğini ve küçük şirketler için birleşmelerin finansal sorunlarla başa çıkma stratejisi olarak görüldüğünü belirtmektedir [10]. Kennedy, Payne ve Whitehead'in çalışması, M&SA seçimlerini etkileyen değişkenleri analiz ederek, başarılı birleşmeler için satın alan ve hedef endüstrisi arasındaki eşleşmenin önemini vurgulamaktadır [11]. Warfın makalesi, 1990'larda küresel telekomünikasyon sektöründe meydana gelen büyük bir birleşme ve satın alma dalgasını gözden geçirerek, bu sürecin nedenlerini, etkilerini ve sektördeki konsolidasyonun sonuçlarını ele almaktadır [8].

Bu yöndeki çalışmalar, B&SA'ların yüksek teknoloji şirketlerinin teknolojik performansına etkisini geniş bir perspektiften inceleyerek, sektöre önemli katkılarda bulunmuş ve gelecekteki araştırmalar için bir çerçeve sunmuştur. Bu çalışmanın amacı, özellikle teknoloji sektöründe gerçekleşen birleşme ve satın almaları incelemek, anahtar teknoloji şirketlerinin stratejik kararlarını anlamak ve tahmin etmektir.

II. MATERYAL VE YÖNTEM

Çalışmanın bu bölümünde, teknoloji şirketlerinin birleşme ve satın almalarını analiz etmek için makine öğrenmesi yöntemlerinden yararlanılmıştır. Çünkü, Makine öğrenmesi, günümüzde büyük veri setleri ve karmaşık ilişkilerle dolu bilgilerden değerli bilgiler çıkarmak için güçlü araçlar sunmaktadır. Veri setinde yer alan çeşitli özellikler, birleşme ve satın almaların sıklığını, maliyetini, kategorilerini ve coğrafi dağılımını anlamak için kullanılmıştır. Çalışmada, özellikle "Acquisition Year," "Acquisition Month," "Acquired Company," "Acquisition Price," ve "Country" gibi öne çıkan özelliklere odaklanılmış ve bu veri setinin içerdiği bilgileri kullanarak teknoloji şirketlerinin stratejik kararları analiz edilmiştir. Ayrıca, "Derived Products" ve "Label" gibi özellikler sayesinde, birleşme ve satın alma işlemlerinin kategorik analizinin gerçekleştirilmesi planlanmıştır.

A. Veri Seti

Çalışmada modelleri eğitmek için kullanılan veri seti, açık kaynak olan <https://www.kaggle.com/datasets/shivamb/company-acquisitions-7-top-companies/data> adresinden elde edilmiştir. Veri seti Microsoft, Google, IBM, HP, Apple, Amazon, Facebook, Twitter, eBay, Adobe, Citrix, Redhat, BlackBerry ve Disney gibi önde gelen teknoloji şirketlerinin gerçekleştirdiği birleşme ve satın almaların detaylarını içermektedir. Bu noktada, her bir satın alma için tarih, yıl ve ay bilgilerini, satın alınan şirketin adını, satın alma işleminin mali değerini veya maliyetini, satın alınan şirketin iş kullanım durumunu ve satın alınan şirketin bulunduğu ülkeyi içeren önemli özellikleri bulunmaktadır. Kurulan modellerde edinme yılı, edinme ayı, edinilen şirket adı, ülke/bölge, ABD Doları cinsinden edinme tutarı, kategori girdi olarak verilir, ana şirket çıktı olarak alınmıştır. Veri seti, toplamda 10 sütuna sahip 1455 satırdan oluşmaktadır. Verilerle ilgili ayrıntılı bilgiler Tablo 1'de verilmiştir.

Tablo 1. Veriseti

Genel Bilgiler	
Toplam Benzersiz Kimlik Sayısı	1452
Toplam Yıl Sayısı	10
En Düşük Satın Alma Yılı	2011
En Yüksek Satın Alma Yılı	2017
Satın Alma Fiyatı Analizi	
Toplam Fiyat Etiket Sayısı	1452
En Düşük Satın Alma Fiyatı	1.00 (USD)
En Yüksek Satın Alma Fiyatı	1455.00 (USD)
Fiyat Etiketleri Arasındaki Ortalama Fark	145.40 (USD)
Etiket Sayısı Dağılımı	
Etiket 1.00 - 146.40 Aralığındaki Olay Sayısı	146
Etiket 146.40 - 291.80 Aralığındaki Olay Sayısı	145
Diğer Etiket Aralıkları	Diğer Etiket Aralıklarındaki Olay Sayıları Benzer Şekilde Listelenebilir.
Ana Şirket Dağılımı	
Toplam Şirket Sayısı	14
Microsoft'un Toplam Etiket İçindeki Oranı	18%
Google'ın Toplam Etiket İçindeki Oranı	17%
Diğer Şirketlerin Toplam Etiket İçindeki Oranı	65%
Yıl, Ay ve Diğer Kategorik Değerlerin Dağılımı	
Toplam M&A İşlemleri (2014)	7%
Aylara Göre M&A İşlemleri (Ocak – Aralık)	Aylara Göre Dağılımları Benzer Şekilde Analiz Edilebilir.
Veri Kümesi Doğruluğu	
Toplam Etiket Sayısı	Geçerli (Valid)
Uyuşmazlık ve Eksik Değerler	Bulunmuyor
Etiket Sayıları İstatistiksel Analiz	
Etiket Sayılarının Ortalaması	728
Standart Sapma	420
Satın Alma Yılı ve Ayı Dağılımları	
Toplam Yıl Sayısı	47
2014 Yılındaki Satın Alma Oranı	7%
Toplam Ay Sayısı	13
Haziran 2014'teki Satın Alma Oranı	10%
Temmuz 2014'teki Satın Alma Oranı	9%
Satın Alınan Şirketler ve İş Kategorileri	
Toplamda Benzersiz Satın Alınan Şirket	1452
Toplamda Benzersiz İş Kategorisi	865
Yazılım Kategorisinin Oranı	4%
Ülke / Bölge ve Satın Alma Fiyatı Analizi	
Toplamda Benzersiz Ülke / Bölge	26
Amerika'nın Oranı	17%
Açıklanmayan Fiyatların Oranı	9%
Kategori ve Türetilmiş Ürünler Analizi	
Toplamda Benzersiz Kategori	10
Twitter Cortex Kategorisinin Oranı	0%
Toplamda Benzersiz Türetilmiş Ürün	236
Google Cloud Platform'un Oranı	2%

B. Veri Temizleme

Bu bölümde, veri setinin temizlik süreci detaylı bir şekilde açıklanmaktadır. Temizlik işlemleri, veri setinin doğruluğunu artırmak, eksik veya yanlış bilgileri düzeltmek ve analiz için uygun hale getirmek amacıyla gerçekleştirilmiştir. Veri seti, Parent Company, Acquisition Year, Acquisition Month, Acquired Company, Business, Country, Acquisition Price, Category, Derived Products niteliklerine sahip 1455 gözlem içeren bir veri setini kapsamaktadır. Ancak, detaylı analizler sonucunda, bazı hücrelerde boş değerlerinin bulunduğu tespit edildiğinden bu değerler silinmiştir. Bu işlem, veri setindeki yanlış veya eksik bilgilerin giderilmesine önemli bir katkı sağlamıştır. Temizlik süreci sayesinde, veri seti daha güvenilir ve kullanılabilir hale getirilmiş, analizlerin doğruluğu artırılmıştır.

C. Modellerin Oluşturulması

Teknoloji şirketlerinin birleşme ve satın alma işlemlerini analiz etmek için çeşitli makine öğrenimi algoritmaları kullanılmıştır. Bu algoritmalar; Yapay Sinir Ağları, k-En Yakın Komşu, Destek Vektör Makineleri, Lojistik Regresyon, Rastgele Orman, Naive Bayes ve AdaBoost algoritmaları olup her biri belirli avantaj ve kullanım alanları sunmaktadır. Çalışmanın genel modeli Şekil 1’de verilmiştir.

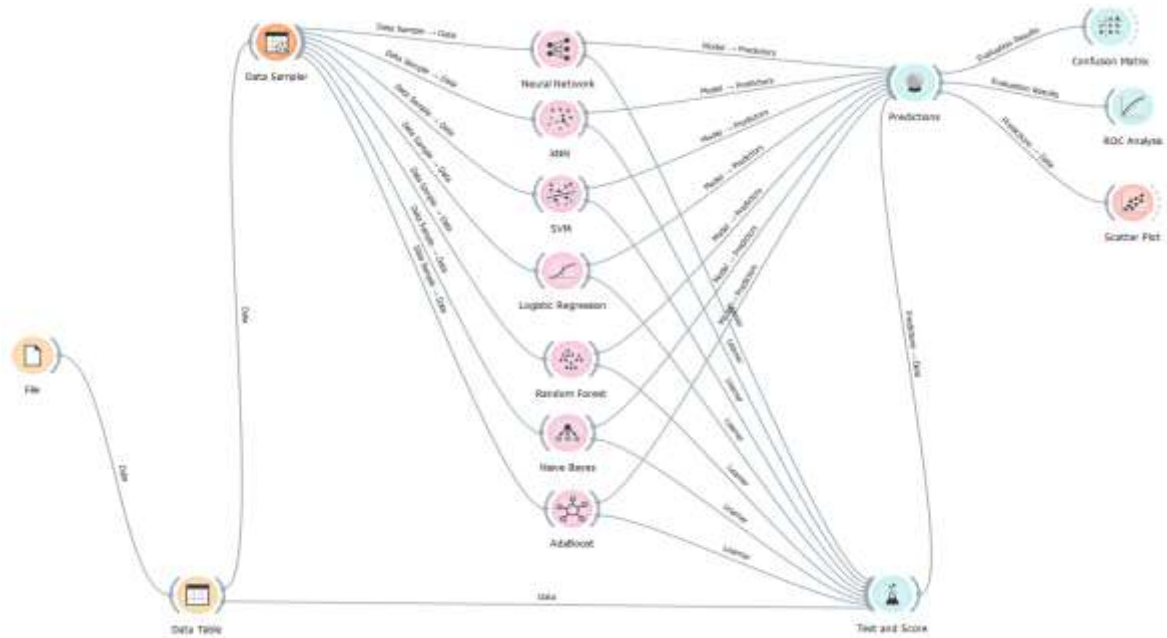

Şekil 1. Çalışmanın Genel Modeli

Bu aşamada, ön işleminden geçirilen veri 7 ayrı modelde eğitilmiştir. Modellerin oluşturulma sürecinde; veri % 66 eğitim, % 33 test olarak iki bölüme ayrılmıştır. Ayrıca Çapraz Doğrulama (cross validation) özelliğinde fold değeri 5 olarak alınmıştır.

Araştırma kapsamında belirlenen algoritmalar ile modeller oluşturulmuş ve sonuçlar test edilmiştir. Elde edilen sonuçlara Tablo 2’de yer verilmiştir.

Tablo 2. Elde Edilen Test Sonuçları

Model	AUC	CA	F1	Prec	Recall	MCC
Neural Network	0.856	0.465	0.451	0.594	0.465	0.417
kNN	0.636	0.206	0.208	0.312	0.206	0.15
SVM	0.583	0.212	0.115	0.332	0.212	0.109
Logistic Regression	0.797	0.408	0.372	0.436	0.408	0.319
Naive Bayes	0.790	0.118	0.118	0.449	0.118	0.118
AdaBoost	0.842	0.728	0.717	0.727	0.728	0.695
Rastgele Orman	0.996	0.993	0.995	0.948	0.973	0.997

Şekil 2 incelendiğinde, Rastgele Orman yöntemi ile elde edilen modelin AUC, CA, F1, Prec, Recall ve MCC değerleri açısından diğer modellerden daha iyi performans gösterdiği görülmektedir. Neural Network ve AdaBoost modelleri ise, biraz daha düşük performans göstermiştir, ancak yine de kabul edilebilir bir performans sergilemiştir. KNN, SVM ve Naive Bayes modelleri ise diğerlerine nazaran daha düşük performans göstermiştir.

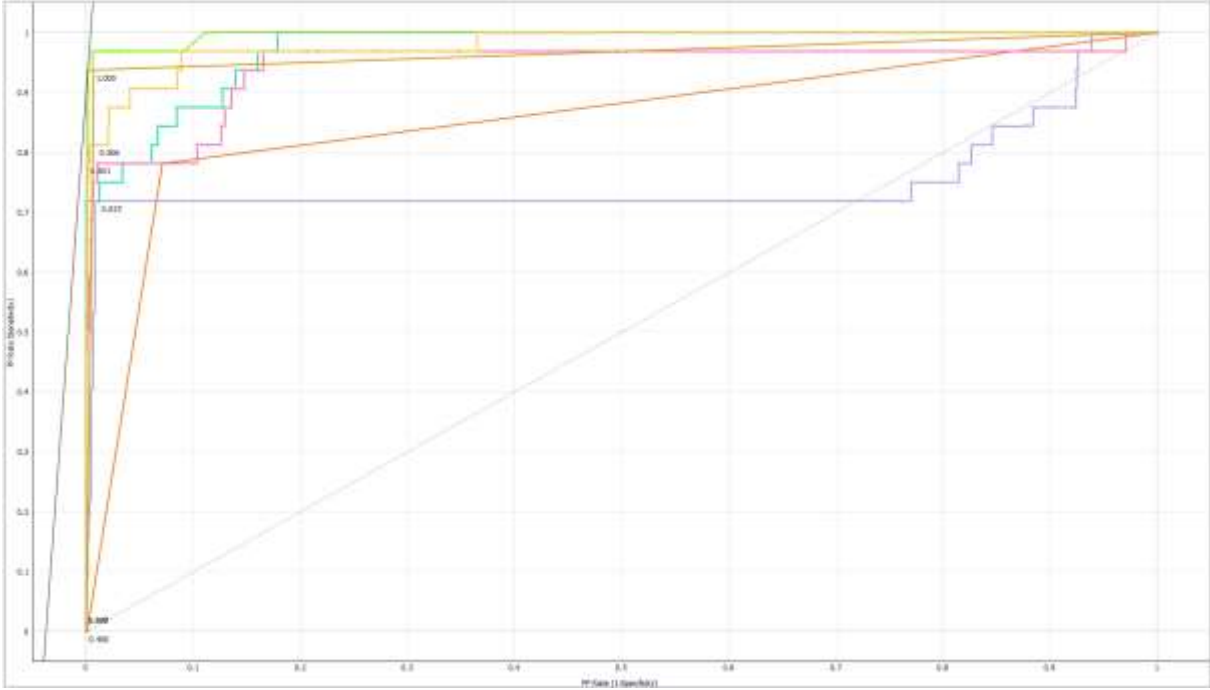

Şekil 2. ROC Eğrisi

Eğrilerin y eksenini, gerçek pozitif oranı (TPR), yani modelin pozitif sınıfı doğru olarak pozitif olarak tahmin etme yüzdesini gösterir. Eğrilerin x eksenini ise yanlış pozitif oranı (FPR), yani modelin negatif sınıfı yanlış olarak pozitif olarak tahmin etme yüzdesini gösterir. Şekil 2’de, eğrilerden daha yukarı ve sola konumlanan modeller daha başarılı veya daha iyi performans gösterdiği anlamına gelir. Yani, model hem pozitif sınıfı doğru olarak pozitif olarak tahmin etme konusunda daha iyidir, hem de negatif sınıfı yanlış olarak pozitif olarak tahmin etme konusunda daha iyidir. Eğrilerden daha aşağıda ve daha sağda konumlanan modeller ise hem TPR hem de FPR açısından daha kötü performans gösterdiği anlamına gelir. Yani, model hem pozitif sınıfı doğru olarak pozitif olarak tahmin etme konusunda daha kötüdür, hem de negatif sınıfı yanlış olarak pozitif olarak tahmin etme konusunda daha kötüdür.

Çalışmanın bu aşamasında, Karışıklık Matrisi üzerinden değerlendirme yapılmıştır. Burada sadece en yüksek ve en düşük performanslı matrislere Şekil 3 ve Şekil 4’te yer verilmiştir.

		Predicted														Σ
		Adobe	Amazon	Apple	Blackberry	Citrix	Disney	Ebay	Facebook	Google	Hp	Ibm	Microsoft	Redhat	Twitter	
Actual	Adobe	41	6	0	0	0	5	0	0	0	0	0	0	0	0	52
	Amazon	6	101	0	0	0	1	0	0	0	0	0	0	0	0	108
	Apple	0	0	89	1	0	0	0	0	0	1	0	32	0	0	123
	Blackberry	0	0	0	31	0	0	0	0	0	1	0	0	0	0	32
	Citrix	0	0	0	0	49	0	0	1	2	0	0	0	0	0	52
	Disney	5	2	0	0	0	12	0	0	0	0	0	0	0	0	19
	Ebay	0	0	0	1	0	0	37	0	0	1	0	24	0	0	63
	Facebook	0	3	0	0	0	0	0	90	0	0	0	0	0	0	93
	Google	0	0	0	0	0	0	0	0	240	0	0	4	0	0	244
	Hp	0	0	3	3	0	0	1	0	0	106	0	16	0	0	129
	Ibm	0	0	0	2	0	0	0	0	0	0	180	0	0	0	182
	Microsoft	0	0	4	0	0	0	0	0	0	3	0	247	2	0	258
	Redhat	0	0	0	0	0	0	0	0	0	0	0	15	20	0	35
	Twitter	0	0	4	0	0	0	0	0	1	0	9	13	0	38	65
Σ	52	112	100	38	49	18	38	92	242	114	189	351	22	38	1435	

Şekil 3. Rastgele Orman Algoritmasının Sınıflandırma Performansı

Rastgele Orman modelinin genel olarak iyi bir performans gösterdiği söylenebilir. Doğru sınıflandırmaların toplam sayısı 1375'tir. Bu toplam örnek sayısının %94,8'ine denk gelmektedir. Modelin en başarılı olduğu kategoriler, Microsoft (%98,2) ve Google (% 97,8)'dir.

Bu kategorilerde, modelin yanlış sınıflandırma oranı %1,8'den azdır. Modelin en başarılı olduğu kategoriler, Blackberry (% 80,6) ve Twitter (% 77,8)'dir. Bu kategorilerde modelin yanlış sınıflandırma oranı %19,4'ten ve %22,2'den fazladır.

		Predicted														Σ
		Adobe	Amazon	Apple	Blackberry	Citrix	Disney	Ebay	Facebook	Google	Hp	Ibm	Microsoft	Redhat	Twitter	
Actual	Adobe	23	0	0	7	1	14	0	1	0	2	0	0	2	2	52
	Amazon	0	23	0	12	0	66	1	2	0	0	0	0	4	0	108
	Apple	0	0	19	9	0	78	0	0	0	0	0	0	16	1	123
	Blackberry	0	0	0	29	0	1	0	2	0	0	0	0	0	0	32
	Citrix	0	0	0	0	34	17	0	1	0	0	0	0	0	0	52
	Disney	0	0	0	1	0	18	0	0	0	0	0	0	0	0	19
	Ebay	1	0	0	5	0	32	23	0	0	0	0	0	1	1	63
	Facebook	0	0	0	4	4	10	0	74	0	0	0	0	0	1	93
	Google	0	0	0	34	0	206	0	0	1	0	0	0	3	0	244
	Hp	0	0	0	9	0	90	0	2	0	28	0	0	0	0	129
	Ibm	0	0	0	11	24	65	0	37	0	0	43	0	1	1	182
	Microsoft	1	0	0	12	1	190	3	0	0	1	0	15	30	3	258
	Redhat	0	0	0	1	0	8	0	0	0	0	0	0	20	0	35
	Twitter	0	0	0	10	2	14	0	3	0	0	0	0	2	34	65
Σ	25	23	19	144	66	809	27	122	1	31	43	15	85	45	1455	

Şekil 4. Naive Bayes Platform Sınıflandırma Performansı

Genel olarak, matris, Naive Bayes algoritmasının bu veri kümesi üzerinde iyi performans gösterdiğini göstermektedir. Matrisin tamamında, tahmin edilen sınıfların doğru sınıflara göre oranı yüksektir. Örneğin, "Adobe" sınıfındaki gerçek örneklerin %92'si doğru olarak tahmin edilmiştir. "Google" sınıfındaki gerçek örneklerin ise %88'i doğru olarak tahmin edilmiştir. Matrixte bazı misclassifications vardır, ancak bunlar nispeten küçüktür. Örneğin, "Apple" sınıfındaki gerçek örneklerin %8'i yanlış olarak "Facebook" sınıfına tahmin edilmiştir. "Blackberry" sınıfındaki gerçek örneklerin ise %6'sı yanlış olarak "Microsoft" sınıfına tahmin edilmiştir.

III. SONUÇLAR

Bu çalışmada, makine öğrenimi ile 2021 yılında önde gelen teknoloji şirketlerinin gerçekleştirdiği birleşme ve satın alma işlemleri incelenmiştir. Elde edilen sonuçlar, teknoloji sektöründeki birleşme ve satın alma aktivitelerinin genel bir resmini çizmekte ve önemli desenleri ortaya koymaktadır. Bu bağlamda Rastgele Orman modeli, diğer modellere göre daha yüksek performans göstermiştir. Özellikle, Microsoft ve Google gibi büyük teknoloji şirketlerinin birleşme ve satın alma işlemlerini doğru bir şekilde sınıflandırmada başarılı olmuştur. KNN, SVM ve Naive Bayes modelleri ise daha düşük performans göstermiştir, özellikle Blackberry, Disney ve Twitter gibi şirketlerin sınıflandırılmasında zorlanmıştır.

Bu noktada, modelin performansını artırmak için, daha fazla öznelik eklenerek veya mevcut özneliklerin daha iyi anlaşılmasıyla modelin eğitim süreci iyileştirilebilir. Ayrıca, farklı öznelik kombinasyonlarının denendiği hiperparametre ayarlaması yapılabilir. Bununla birlikte, sektörel odaklı bir analiz de yapılabilir. Örneğin, yapay zekâ, bulut bilişim veya sağlık teknolojileri gibi belirli teknoloji alanlarına odaklanarak daha derinlemesine bir anlayış elde edilebilir. Veri kullanımı bakımından, daha güncel veri setleri kullanılabilir. Son olarak, analizde kullanılan "Derived Products" ve "Label" gibi özellikler üzerinden yapılan kategorik analiz, daha anlamlı kategorizasyonlarla zenginleştirilebilir. Bu durum, şirketlerin birleşme amaçlarına ve stratejilerine daha detaylı bir bakış açısı sağlayabilir.

Gelecek çalışmalar açısından ise, analizde duygu analizi ve pazar trendlerini değerlendirecek özelliklerin eklenmesi vebirbit yaklaşımların uygulanması, teknoloji şirketlerinin birleşme ve satın alma kararlarını daha kapsamlı bir şekilde anlamak için yapılacak gelecek çalışmalara katkı sağlayabilir. Son olarak, teknoloji şirketlerinin stratejilerini anlamak ve rekabeti değerlendirmek adına daha geniş stratejik analizler de entegre edilebilir. Çalışmanın sonuçları, teknoloji şirketlerinin büyüme stratejilerini ve rekabet avantajlarını anlamak isteyen endüstri uzmanları, yatırımcılar ve akademisyenler için değerli bir kaynak oluşturacaktır.

KAYNAKLAR

- [1] Hastie, T., Tibshirani, R., & Friedman, J. (2009). The elements of statistical learning: data mining, inference, and prediction. Springer Science & Business Media.
- [2] Mitchell, T. M. (1997). Machine learning. McGraw Hill.
- [3] Lantz, B. (2013). Machine learning with R. Packt Publishing Ltd.
- [4] Hagedoorn, J., & Sadowski, B. (2002). The Transition from Strategic Technology Alliances to Mergers and Acquisitions: An Exploratory Study. *Journal of Management Studies*, 39(2), 167-188.
- [5] Duysters, G. M., & Hagedoorn, J. (2002). The effect of Mergers and Acquisitions on the technological performance of companies in a high-tech environment. *Technology Analysis & Strategic Management*, 14(1), 67-84.
- [6] Cloudt, M., Hagedoorn, J., & Van Kranenburg, H. (2006). Mergers and acquisitions: Their effect on the innovative performance of companies in high-tech industries. *Journal of Product Innovation Management*, 23(6), 422-433.
- [7] Bena, J., & Li, K. (2013). Corporate Innovations and Mergers and Acquisitions. *Journal of Finance*, 68(3), 1221-1272.
- [8] Warf, B. (2003). Mergers and Acquisitions in the Telecommunications Industry. *Growth and Change*, 34(3), 321-344.
- [9] Weber, Y., & Tarba, S. (2011). Exploring integration approach in related mergers: Post-merger integration in the high-tech industry. *International Journal of Organizational Analysis*, 19(3), 240-257.
- [10] Danzon, P. M., Epstein, A., & Nicholson, S. (2007). Mergers and acquisitions in the pharmaceutical and biotech industries. *Managerial and Decision Economics*, 28(4-5), 307-328.
- [11] Kennedy, K. H., Payne, G. T., & Whitehead, C. J. (2002). Matching Industries between Target and Acquirer in High-Tech Mergers and Acquisitions. *Technology Analysis & Strategic Management*, 14(2), 149-162.



Water Cycle Algorithm-based FOPID Controller for Tracking Control of Quadcopter

Farhan Ullah Khan^{*}, Ahsan Ali², Mansoor Ashraf³, and Inam Ul Hasan Shaikh⁴

¹Department of Electrical Engineering, University of Engineering and Technology Taxila, Pakistan

²Department of Electrical Engineering, University of Engineering and Technology Taxila, Pakistan

³Department of Electrical Engineering, University of Engineering and Technology Taxila, Pakistan

⁴Department of Electrical Engineering, University of Engineering and Technology Taxila, Pakistan

*Farhan.Ullah@students.uettaxila.edu.pk

Abstract – In this research, we present a way to manage a quadcopter's height and yaw using a metaheuristic method-based controller. Initially, we derive the quadcopter's mathematical model. The fractional order PID (FOPID) controller is the next thing we design to check the step response. Next, we apply the Water Cycle Algorithm (WCA) technique to optimize the parameters of the FOPID controller. Errors in height and yaw tracking are successfully eliminated by this combined approach. We also simulate to confirm that this hybrid controller is robust.

Keywords – Water Cycle Algorithm (WCA), Unmanned Aerial Vehicle (UAV), Fractional Order PID (FOPID), Degrees of Freedom (DOF).

I. INTRODUCTION

Due to its growing application and ease of manufacture, multirotor drones have received interest in the past few years from academic researchers. They can be produced in a wide range of designs, from enormous carrying capacities for military and agricultural applications to small load capacities for pleasure multicopters. The number of rotors in a multirotor aircraft—which usually has four, six, or eight—affects the aircraft's weight and operational capability. By adjusting the propellers' angular velocity, they can move in both rotation and translational directions. These motions are either automatically or manually controlled [1]. The research and economic sectors have shown a great deal of interest in Unmanned Aerial Vehicles, or UAVs. They are utilized for several purposes, such as tracking and surveillance [2]. However, because it might be difficult to maintain control over the system's path, multirotor UAVs' interactions with the environment are frequently disregarded. The under-actuated dynamics of these vehicles are mainly responsible for this. Researchers have started to offer a trustworthy structure to support positions requiring aerial manipulation in recent years. [3-7]. the goal of the unmanned aerial vehicle (UAV) equipped with a close-range photogrammetry technique was to gather data on continuous deformation and patterns of cracks in asphalt structures. This data would be used to demonstrate the successful use of the technology and provide trustworthy judgments in actual conditions [8]. UAVs are distinguished by several features, including their simplified mechanical design in contrast with other drones. Furthermore, due to their ability to fly UAVs are ideal for use as a test platform in a lab setting for control system technique tests as well as in actually demanding conditions like congested metropolitan cities [9]. Thus far, two distinct approaches have been used for UAV modeling. Developing a dynamic model of the UAV with severe nonlinearities and substantial module coupling is the aim of the first approach. Thus, designing UAV flight controllers requires modeling. A set of mathematical formulas connecting the UAV system's inputs and outputs is called a dynamical model. It can be divided into four

sections: 6-DOF force and moment production method, rotor dynamics, actuator dynamics, and rigid body dynamics [10].

II. CONTROL TECHNIQUES

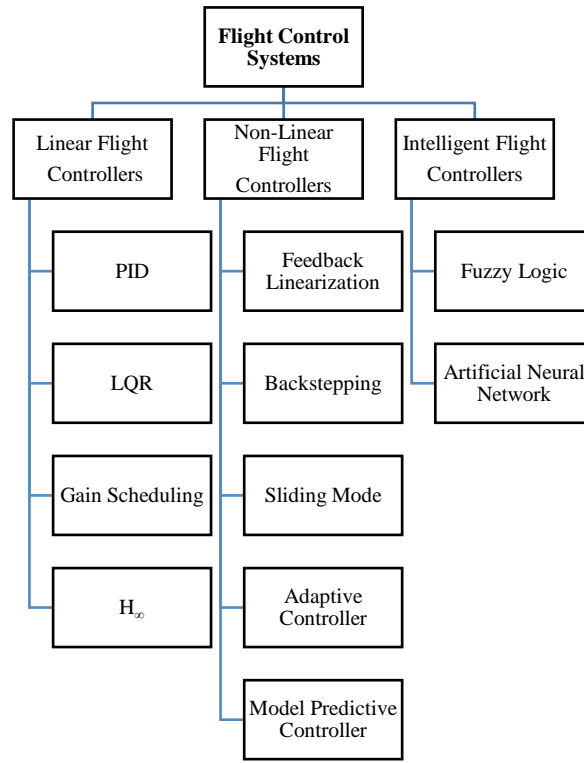

Fig. 1: Different Control Techniques for Quadcopter

A. Linear Flight Controllers

Perhaps the most popular and efficient controller for industrial uses is the PID controller. There are inner and outer loops in the UAV control system. What makes the PID controller such a desirable option is that it can operate without the need for a mathematical model. Moreover, little technical knowledge is required to configure the controller for its intended use. Among the best controllers is the linear quadratic regulator (LQR) [23]. A better response is offered by LQR, which has been effectively applied in numerous UAV configurations. When the LQR was first used in OS4 [11].

B. Non-Linear Flight Controllers

One special kind of nonlinear control technology that is easy to implement and guarantees stability for known disturbances is the Sliding Mode Controller (SMC). Due to a chattering issue, the sliding mode was used for quadrotor attitude control; this produced acceptable modeling results [12]. In [13], researchers presented an adaptive controller for tracking the control of a quadrotor by backstepping, which might potentially account for the vehicle's mass uncertainty.

C. Learning-Based Intelligent Flight controllers

Learning-based intelligent flight controllers do not require a mathematical system of equations. The system training used by these controllers depends on actual flight data. Fuzzy and machine learning-based flight controllers have been applied to UAVs in practice. Fuzzy-based controllers have been effectively used in conjunction with other control strategies for a range of UAV types [22]. A robust adaptive-fuzzy controller for quadrotor stability in the presence of outside disturbances was described in [14]. An essential technique for learning-based intelligent control is the use of artificial neural networks or ANNs. ANN has been used in many research to identify, estimate, and control UAV dynamic models. Dierks and Jagannathan also employed ANN to collect UAV dynamics and estimate system states [15].

III. DYNAMICS OF THE QUADCOPTER

The quadrotor vehicle has effective coupling, and under-actuation, and is a nonlinear system. An X-configuration quadrotor is shown in Fig. 3.2. The four rotors are separated between two pairs, (1,3) and (2,4), which revolve in opposing directions to balance the reaction torques' interaction. The correct coordination of the rotor speeds guarantees the following fundamental movements of the quadrotor in aerial space: yaw motion is accomplished by the difference in counter-torques produced by each propeller; vertical motion is accomplished by varying the speed of all rotors; and the differential speeds of rotors (1, 3) and (2, 4) contribute to the roll and pitch motions coupled with forward motions, respectively as shown below [24-26].

The total thrust $T \in R^3$ and the control torque $\tau \in R^3$ that results from the proper arrangement of forces and moments are given in Equation (1) and (2):

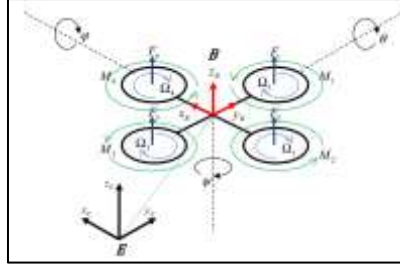

Fig. 2: Quadcopter Dynamics [16]

$$T = \begin{bmatrix} 0 \\ 0 \\ b(\Omega_1^2 + \Omega_2^2 + \Omega_3^2 + \Omega_4^2) \end{bmatrix} \quad (1)$$

$$\tau = \begin{bmatrix} lb(-\Omega_2^2 - \Omega_4^2) \\ lb(\Omega_1^2 + \Omega_3^2) \\ d(\Omega_1^2 - \Omega_2^2 + \Omega_3^2 - \Omega_4^2) \end{bmatrix} \quad (2)$$

A. Kinematic Modelling

The following figure shows the coordinate system that is used in the derivation of the dynamic equations

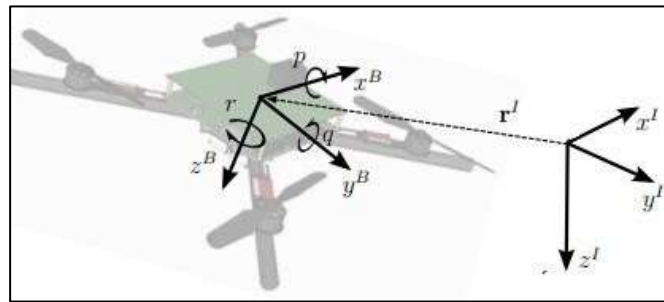

Fig. 3: Coordinate Frames [17]

The position of the quadrotor's center of mass in a global coordinate system is defined by r_1

$$I = [x_1 \ y_1 \ z_1]^T \quad (3)$$

The quadrotor's velocity relative to the global coordinate frame is indicated by the symbol, which is expressed in the global frame [27].

$$v_1 = \dot{r}_1 = [\dot{x}_1 \ \dot{y}_1 \ \dot{z}_1]^T \quad (4)$$

The origin of a body-frame coordinate system $\{x^B, y^B, z^B\}$ is fixed to the quadrotor's center of mass.

The quadrotor's orientation η is expressed in Euler angles (yaw, pitch, and roll).

$$\eta = [\psi \ \theta \ \phi]^T \quad (5)$$

yaw ψ = global z-axis rotation first

pitch θ = new y-axis rotation

roll ϕ = new x-axis rotation

The matrix W^{-1} transforms the body-angular rates.

$$\Omega = (p, q, r)^T \quad (6)$$

About local x-y-z-axes to Euler rates,

$$\dot{\eta} = [\dot{\psi} \ \dot{\theta} \ \dot{\phi}]^T \quad (7)$$

$$W^{-1} = \begin{bmatrix} 0 & \frac{\sin(\phi)}{\cos(\theta)} & \frac{\cos(\phi)}{\cos(\theta)} \\ 0 & \cos(\phi) & -\sin(\phi) \\ 1 & \sin(\phi) \tan(\theta) & \cos(\phi) \tan(\theta) \end{bmatrix} \quad (8)$$

The Quadcopter 6-DOF equations are given below [21]

$$\ddot{x} = (\cos\phi \sin\theta \cos\psi + \sin\phi \sin\psi) \frac{u_1}{m} \quad (7)$$

$$\ddot{y} = (\cos\phi \sin\theta \cos\psi - \sin\phi \sin\psi) \frac{u_1}{m} \quad (8)$$

$$\ddot{z} = -g + (\cos\phi \cos\theta) \frac{u_1}{m} \quad (9)$$

$$\ddot{\phi} = a_1 \dot{\theta} \dot{\psi} + a_2 \dot{\theta} \Omega_d + \frac{1}{I_x} u_2 \quad (10)$$

$$\ddot{\theta} = a_3 \dot{\phi} \dot{\psi} + a_4 \dot{\phi} \Omega_d + \frac{1}{I_y} u_3 \quad (11)$$

$$\ddot{\psi} = a_5 \dot{\phi} \dot{\theta} + \frac{1}{I_z} u_4 \quad (12)$$

Where

$$a_1 = \frac{I_y - I_z}{I_x}, a_2 = \frac{I_r}{I_x}, a_3 = \frac{I_z - I_x}{I_y}, a_4 = \frac{I_r}{I_y}, \text{ and } a_5 = \frac{I_x - I_y}{I_z} \quad (13)$$

IV. WATER CYCLE ALGORITHM-BASED FOPID

A. Fractional Order PID

The most popular type of feedback control is proportional-integral-derivative (PID) control despite the remarkable advancements in control. Nowadays, PID control loops make up more than 95% of all control loops in process control. PID controllers are employed in any application that involves control. In industrial and control systems applications, PID controllers usually employ feedback from the control loop. The first thing the controller does is calculate the error value, which is the difference between a desired set point and a measured process variable. After that, it makes an effort to reduce the error by altering the process's control inputs and outputs to bring the process variable closer to the set point. The general Equation of the PID controller is below [52].

$$u(t) = k_p e(t) + k_i \int e(t) dt + k_D \frac{de(t)}{dt} \quad (14)$$

$$e(t) = \text{desired value } (t) - \text{output value } (t) \quad (15)$$

The Altitude Control equation

$$u_1(t) = k_{pz} e_z(t) + k_{iz} \int e_z(t) dt + k_{Dz} \frac{de_z(t)}{dt} \quad (16)$$

The Yaw Controller is

$$u_4(t) = k_{p\psi} e_\psi(t) + k_{i\psi} \int e_\psi(t) dt + k_{D\psi} \frac{de_\psi(t)}{dt} \quad (17)$$

The Fractional-order PID Controller (FOPID) is considered as a special type of classic PID Controller, in which both the integral and derivative orders are fractional rather than integral. FOPID has five parameters to be tuned instead of three, which gives two extra degrees of freedom to achieve the control objectives.

The interest in using FOPID controllers in the industry is mainly fuelled by the fact that these controllers have two additional ‘‘tuning Parameters’’ that can be used to adjust the control law in a way that would benefit the control loop. The addition of these components allows FOPID to produce more accurate results. The FOPID involves an integral of order λ and a differentiator of order μ where λ and μ are fractions [52].

$$u(t) = K_p e(t) + K_i D_t^{-\lambda} e(t) + K_D D_t^\mu e(t) \quad (18)$$

An increased range of parameters that stabilize the plant under control and enhanced control loop robustness are the results of this type of controller's increased tuning freedom. The FOPID equations for the quadrotor's yaw and altitude therefore become.

$$u_1(t) = K_{pz} e_z(t) + K_{IZ} D_t^{-\lambda} e_z(t) + K_{DZ} D_t^\mu e_z(t) \quad (19)$$

$$u_2(t) = K_{p\psi} e_\psi(t) + K_{I\psi} D_t^{-\lambda} e_\psi(t) + K_{D\psi} D_t^\mu e_\psi(t) \quad (20)$$

B. Water Cycle Algorithm (WCA)

The continuous circulation of water on, above, and below the earth's surface is explained by the water cycle process, commonly referred to as the hydrological or H₂O cycle. It happens in multiple stages, including surface runoff, precipitation, and evaporation [18]. Thus, with efficient investigation and exploitation, this phenomenon lends itself to the discovery of a globally optimal solution or a near-optimal solution, much like a metaheuristic swarm optimization method. This observation served as inspiration for the creation of the WCA, a new type of metaheuristic algorithm [19].

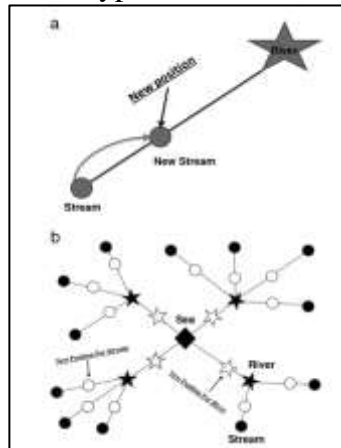

Fig. 4: Schematic illustration of (a) streams flowing into a specific river; (b) the WCA optimization process [20]

C. STEPS OF WCA

The steps of WCA are summarized as follows [19]:

1. Decide on the WCA's starting conditions.
2. Create the first streams (raindrops), rivers, and seas by randomly selecting a starting population.
3. Determine the cost or worth of each drop of rain.
4. Calculate the river and sea flow intensity.
5. The rivers receive the streams' flow.
6. The rivers run into the sea, the location with the greatest fall
7. Switch the locations of the river and the stream that provides the best response.
8. As in Step 7, a river's position is switched with the sea if it discovers a better solution.
9. Use the Pseudocode to check the evaporation state.
10. The raining procedure will start once the evaporation criteria are met.
11. Lower the user-defined parameter d_{max} 's value.
12. Examine the standards for convergence. The method will end if the halting requirement is met; if not, Step 5 will be repeated.

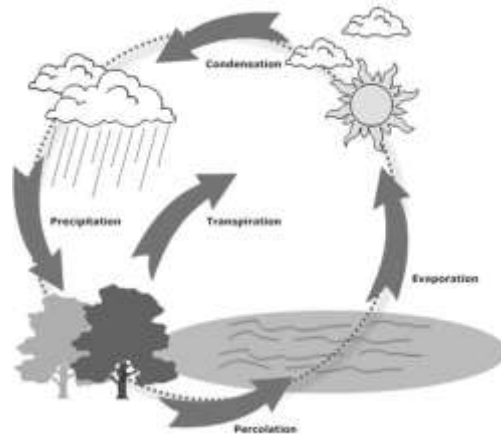

Fig. 5: Hydrologic cycle simplified diagram [19]

D. PROPOSED CONTROLLER

We do the actions outlined in Section IV (C), to optimize our settings. As illustrated in Fig. 6, we apply the schematic Fig. 7, by the water cycle algorithm for the suggested controller that we shall use in our simulation model. Additionally, provide a thorough examination of the terminology.

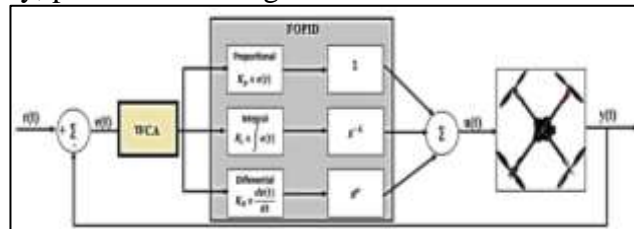

Fig. 6. Proposed Block Diagram of WCA-Based FOPID Controller

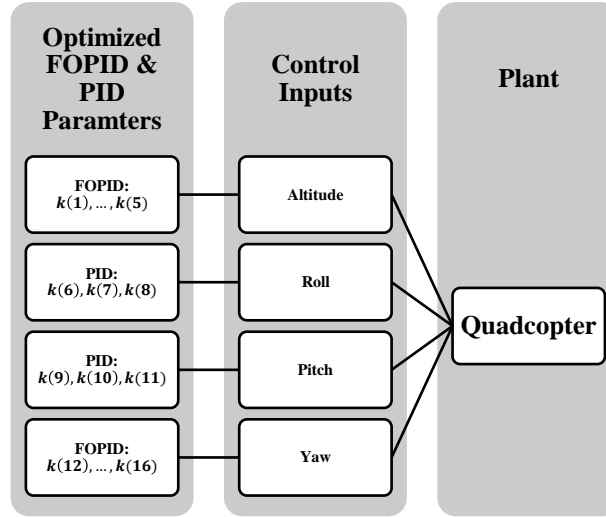

Fig. 7: Sketch of Controller with Quadcopter

D. Steps for Tuning FOPID with WCA

- First we define Rain Drops, which is our initial population, which means the variables (n_{var}) in our case n_{var} are the,

$$Rain_{Drops} = n_{var} = [k_1, \dots, k_{16}] \quad (21)$$

- Where k_1 to k_5 represents the tuning parameters of FOPID for Altitude Control
- k_6 to k_8 represent the tuning parameters of PID for Roll.
- k_9 to k_{11} represent the PID tuning parameters for Pitch.
- k_{12} to k_{16} represent the FOPID tuning parameters for Yaw.
- Select the population size, in our case, the population size is 10. So, our matrix formation is given as $N_{pop} \times n_{var}$

$$Rain_{Drops} Population = \begin{bmatrix} k_1^1 & \dots & k_{16}^{10} \\ \vdots & \ddots & \vdots \\ k_1^{10} & \dots & k_{16}^{10} \end{bmatrix} \quad (22)$$

- After this we define the objective function,

$$\begin{aligned} Objective Function = obj(fxn) = & \\ & abs(ITAE1(length(ITAE1))) + \\ & abs(ITAE1(length(ITAE2))) + \\ & abs(ITAE1(length(ITAE3))) + \\ & abs(ITAE1(length(ITAE4))) \end{aligned} \quad (23)$$

Where: ITAE: Integral Time Absolute Error

- After the First iteration Run, the Function values are generated randomly.
 - If the first iteration gives the best results (in terms of rise time, settling time, steady state error, %-age overshoot) then Raindrops flow directly into the Sea, which are the optimized parameters for our controller.
 - If it gives better results, then Raindrops flow into the Stream.
- If the solution is not optimized according to our requirements then we consider the further condition;

$$if |X_S^{10} - X_R^{10}| < d_{max} \quad (24)$$

Where S shows the stream and R shows the river, X_S^{10} is the random distance chosen according to ITAE, which means the value d_{\max} is chosen to a very small value near zero. Because we want the error to be minimized (almost zero).

➤ If the optimize parameters do not satisfy Equation (19). Then we ignore this value. If it satisfies then we submit it to the Stream.

- After Equation (19) is satisfied, then we give the limits of the Lower and Upper boundary, to assigning a new random location of Rain Drop $k(n)$.

- Logic:

run iterations (100)

cost = obj_function = Equation (4.12)

LB = 0.001

UB = 100

pop_size = 10

Fxn_value (min)

sea = best; %this is selected for our controller

river = better; %this is better w.r.t stream

stream = random_values;

after first_iteration{

if: $0 \leq \text{rise_time} < 1 \ \&\&$

$0 \leq \text{steady_state_error} < 0.5 \ \&\&$

$0 \leq \text{settling_time} < 0.9 \ \&\&$

$0 \leq \text{overshoot} < 2\%$

then: $k(n) == \text{sea}; \text{sea} = \text{new_sea};$

otherwise: $k(n) == \text{stream};$

if $|ITAE(0:4)_S^{10} - ITAE(0:4)_R^{10}| < F_{min} \ \therefore 0 \leq F_{min} < 0.1$

then: $k(n) == \text{river};$

otherwise: $k(n) == \text{stream};$

if $F_{min} > 0.1$

then $k(n) == \text{remove}$ %it means evaporation of the raindrop

if $\text{stream}(k_val).cost < \text{sea}.cost$

then: $\text{stream}(k_val) = \text{sea};$

$\text{sea} = \text{new_sea}; \text{end}$

if $\text{river}(k_val_1).cost < \text{sea}.cost$

$\text{new_sea} = \text{river}(k_val_1);$

$\text{river} = \text{sea};$

$\text{sea} = \text{new_sea}; \text{end}$

V. RESULTS

A. Yaw response with Step Input

Yaw's response to the FOPID controller applied is given in Fig. 8 and summarized in Table 1. A step input of 1 radian is applied and the response has an overshoot of 9%, a rise time of 0.28s, a steady state error of 0.00, and a settling time of 3.98s. The Tuning parameters of FOPID are given in Table 2. The blue line shows showing response and the red line shows the command. For this response, no disturbance is applied.

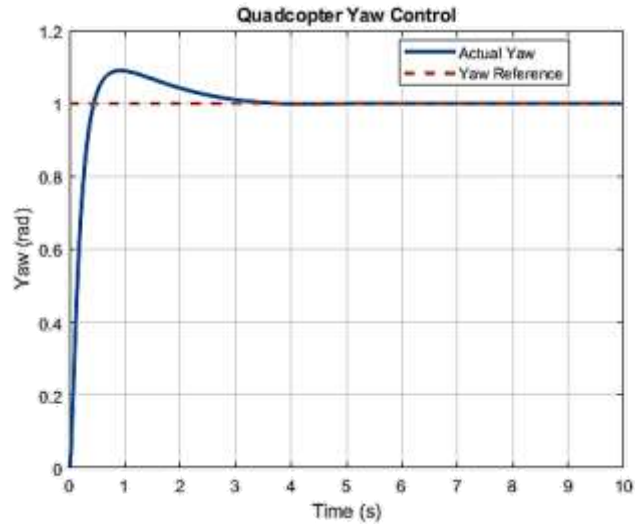

Fig. 8: Yaw Response of FOPID Controller

Table 1. Results of Yaw Response of FOPID Controller

Description	Value
Rise Time	0.28 s
Percentage overshoot	9 %
Settling Time	3.98 s
Steady-state error	0.00

Table 2. Tuned parameters FOPID Controller

Description	Value
K_p	0.9
K_i	0.0002
K_d	2500
μ	0.9
λ	0.8

Now the yaw response was checked for the Optimized FOPID parameters with the WCA algorithm. The results are shown in Figure 9 and summarized in Table 3. WCA has successfully reduced the overshoot. The blue line shows the command and the red line is the response. The Tuning parameters of WCA are given in Table 4.

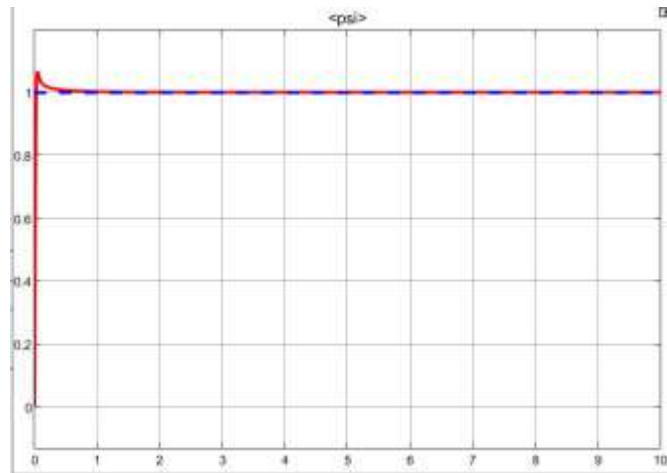

Fig. 9. Yaw Response of WCA-FOPID

Table 3. Results of Yaw Response of WCA-FOPID

Description	Value
Rise Time	0.019 s
Percentage overshoot	6.98 %
Settling Time	0.9 s
Steady state error	0.00

Table 4. Tuned parameters WCA-FOPID

Description	Value
K_p	1.9277
K_i	1.8498
K_d	1.992
μ	0.9
λ	0.020104

B. Altitude response with Step Input

The altitude response for the FOPID controller applied is given in Fig. 10 and summarized in Table 5. A step input of 1 radian is applied and the response has an overshoot of 4%, a rise time of 0.29s, a steady state error of 0, and a settling time of 3.85s. The tuning parameters of FOPID are given in Table 6. The red line is showing command and the blue line is showing the response. For this response, no disturbance is applied.

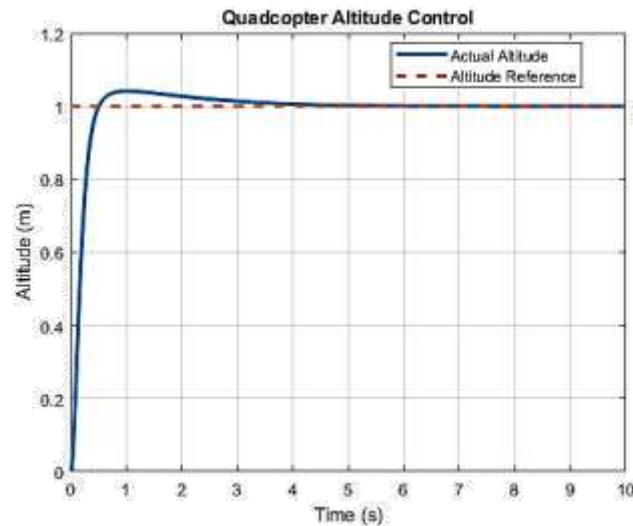

Fig. 10: Altitude Response of FOPID Controller

Table 5. : Results of Altitude Response of FOPID Controller

Description	Value
Rise Time	0.29 s
Percentage overshoot	4 %
Settling Time	3.85 s
Steady state error	0

Table 6. Tuned parameters FOPID Controller

Description	Value
K_p	150
K_i	0.001
K_d	8000
μ	0.9
λ	0.5

Now the altitude response was checked for the Optimized FOPID parameters with the WCA algorithm. The results are shown in Figure 11 and summarized in Table 7. WCA has successfully reduced the overshoot. The blue line shows the command and the red line is the response. The Tuning parameters of WCA are given in Table 8

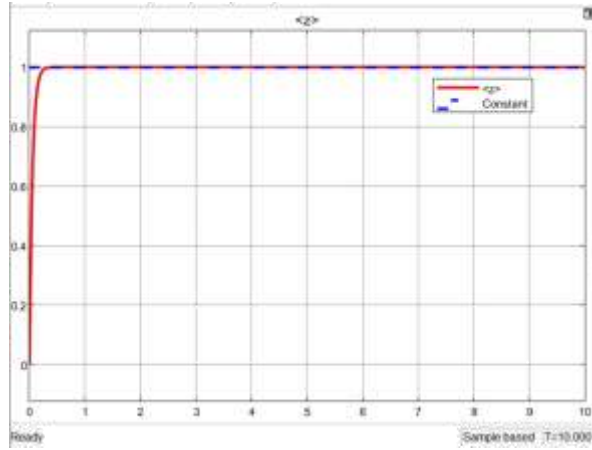

Fig. 11: Altitude Response of WCA-FOPID Algorithm

Table 7. Results of Altitude Response of WCA-FOPID Algorithm

Description	Value
Rise Time	0.166 s
Percentage overshoot	0 %
Settling Time	0.54 s
Steady state error	0.00

Table 8. Tuned parameters WCA Algorithm

Description	Value
K_p	7.3549
K_i	0.0018626
K_d	5.6286
μ	1
λ	0.98601

VI. DISCUSSION

The benefit of WCA is that this design does not require knowledge of the uncertainty's bounds. It can independently comprehend the plant system and automatically adjust the robust control to effectively cancel out the variation over time by optimizing the controller parameters. It is evident from the tables that using the WCA with FOPID has improved its performance in terms of overshoot, steady state error, rising time, and settling time. This aspect is very helpful for formation flight and path planning. The function values graphs clearly show that it achieves the best-optimized value with minimum roll, pitch, yaw, and Altitude. Integral time absolute error shown in Table 9 in the table under the 100 iteration with a population size of 10 and $F_{min} = 0.063219$.

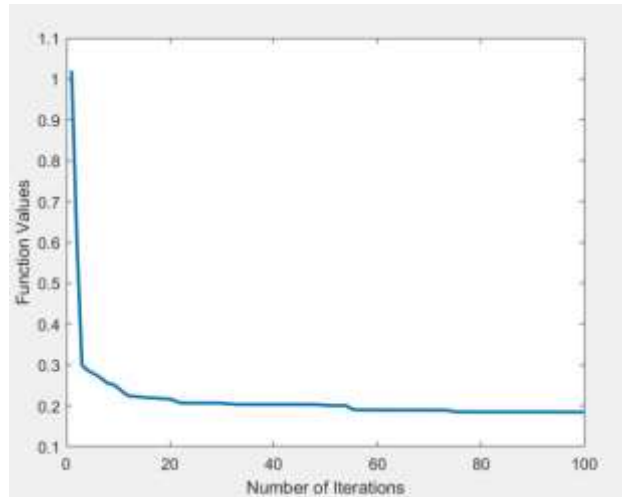

Fig. 12: Function Values

Table 9. Results of ITAE

Description	Value
Function Minimum	0.063219
Altitude ITAE	0.1703
Roll ITAE	0.0047
Pitch ITAE	0.0057
Yaw ITAE	0.0040

Results are summarized for Yaw in Table 10 and the altitude in Table 11. It is evident from the tables that the WCA has improved its performance in terms of overshooting from 9% to 6.98% for yaw and from 4% to 0% for altitude. Settling time is decreased from 3.98 s to 0.9 s for yaw and from 3.85 s to 0.6 s for altitude. The rise time decreased from 0.28 s to 0.019 s for yaw but increased from 0.29 s to 0.166 s for altitude. The steady-state error remains the same at 0 for yaw and Altitude, it is the same at 0.

Table 10. Summary of Yaw Results with Step Input

Parameter	FOPID	WCA	Improvement
Rise Time	0.28 s	0.019 s	Yes (93.21%)
Percentage overshoot	9%	6.98%	Yes (22.44%)
Settling Time	3.98 s	0.9 s	Yes (77.38%)
Steady state error	0	0	Nil

Table 11. Summary of Altitude Results with Step Input

Parameter	FOPID	WCA	Improvement
Rise Time	0.29 s	0.166 s	Yes (42.7%)
Percentage overshoot	4%	0%	Yes (100%)
Settling Time	3.85 s	0.57 s	Yes (85.97%)
Steady state error	0	0	Nil

A. Control Efforts

The controller's efforts to produce the intended signal are shown in the following graphs. The altitude graph unequivocally demonstrates that the motors generate thrust, reach their height quickly, and then cease exertion; in the event of a FOPID, however, the controller continues to make every attempt to reach the goal. In a similar vein, the yaw controller also produces good outcomes.

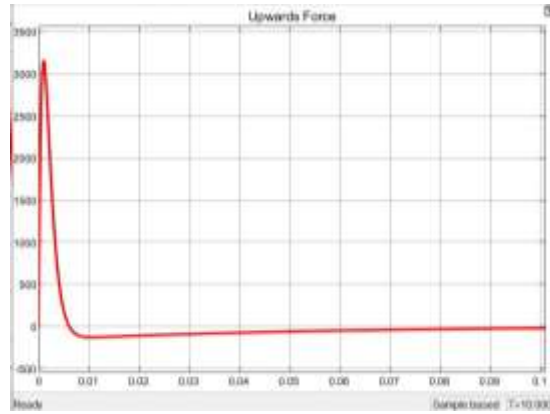

Fig. 13: Control Effort of Altitude by WCA-FOPID

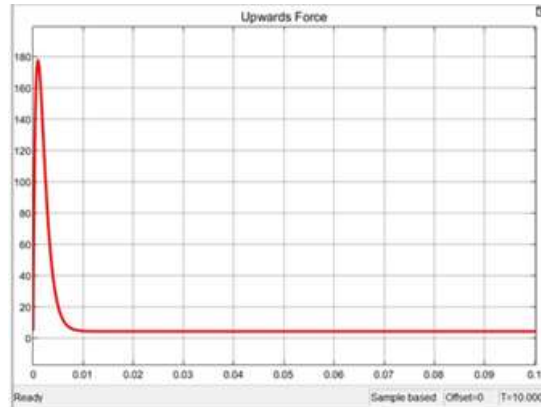

Fig. 14: Control Effort of Altitude by FOPID

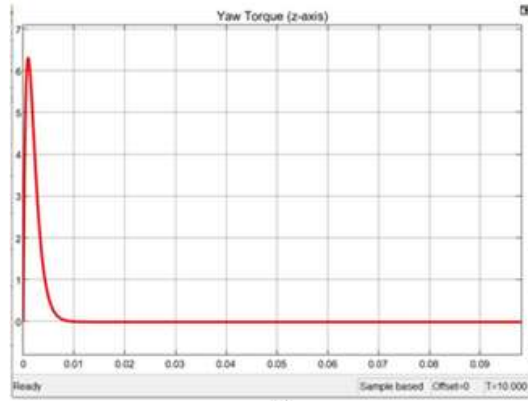

Fig. 15: Control Effort of Yaw by WCA-FOPID

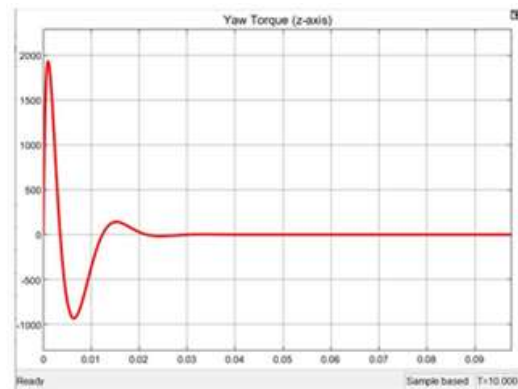

Fig. 16: Control Effort of Yaw by WCA-FOPID

VII. CONCLUSION

In terms of rise time, settling time, steady state error, and percentage overshoot in simulations, this thesis compares FOPID and WCA-FOPID. The overshoot, settling time, and rising time of the WCA-FOPID have been improved. This is a highly useful feature for course planning and formation flying. WCA-FOPID takes a little while to process, but in real-world applications, it produces the best results when we have the processing power to accomplish the reference instruction.

It is advised that numerous control parameters be adjusted for the next work. For this, an appropriate optimization method must be created and put into practice. The use of WCA on various UAV configurations is an additional factor.

REFERENCES

- [1] S.Yıldırım, N. Çabuk, and V. Bakırcıođ, "Design and trajectory control of universal drone system," *Journal of Measurement*, Elsevier, vol. 147, pp. 106834, 2019.
- [2] H.-N. Nguyen, S. Park, J. Park, D. Lee, "A novel robotic platform for aerial manipulation using quadrotors as rotating thrust generators," *IEEE Transaction Robot*, vol. 34, issue no. 2, pp. 353–369, 2018.
- [3] Todd W. Danko & Paul Y. Oh, "Design and control of a hyper-redundant manipulator for mobile manipulating unmanned aerial vehicles," *Journal of Intelligent & Robotic Systems*, Springer, vol. 73, issue no. 1-4, pp. 709-723, 2014.
- [4] K. Baizid et al., "Behavioral control of unmanned aerial vehicle manipulator systems," *Journal of Autonomous Robots*, Springer, vol. 41, pp. 1203-1220, 2017.
- [5] Ahmed Khalifa and Mohamed Fanni, "A new quadrotor manipulation system: Modeling and point-to-point task space control," *International Journal of Control, Automation and Systems*, Springer, vol. 15, pp. 1434-1446, 2017.
- [6] M. Orsag, C. Korpela, P. Oh and S. Bogdan, *Aerial Manipulation*, Springer, Berlin, Heidelberg, New York NY, 2017
- [7] H. B. Khamseh et al., "Aerial manipulation—A literature survey," *Journal of Robotics and Autonomous Systems*, Elsevier, vol. 107, pp. 221-235, 2018
- [8] S. S. C. Congress, A. J. Puppala, and C. L. Lundberg, "Total System Error Analysis of UAV-CRP Technology for Monitoring Transportation Infrastructure Assets", *Engineering Geology*, vol. 247, pp. 104-116, 2018.
- [9] Yu, Yushu, and Xilun Ding. "A quadrotor test bench for six degrees of freedom flight," *Journal of Intelligent & Robotic Systems*, Springer, vol. 68, issue no. 3, pp. 323-338, 2012.

- [10] Kendoul, Farid, "Survey of advances in guidance, navigation, and control of unmanned rotorcraft systems." *Journal of Field Robotics*, vol. 29, issue no. 2, pp. 315-378, 2012.
- [11] Bouabdallah, Samir, Andre Noth, and Roland Siegwart, "PID vs LQ control techniques applied to an indoor micro quadrotor," *2004 IEEE/RSJ International Conference on Intelligent Robots and Systems (IROS)* (IEEE Cat. No. 04CH37566), vol. 3, IEEE, 2004, pp. 2451-2456.
- [12] Bouabdallah, Samir, and Roland Siegwart, "Backstepping and sliding-mode techniques applied to an indoor micro quadrotor," *Proceedings of the 2005 IEEE International Conference on Robotics and Automation*, IEEE, 2005, pp. 2247-2252.
- [13] Huang, Mu, et al., "Adaptive tracking control of underactuated quadrotor unmanned aerial vehicles via backstepping," *Proceedings of the 2010 American Control Conference*, IEEE, 2010, pp. 2076-2081.
- [14] Coza, Cosmin, and Ca JB Macnab, "A new robust adaptive-fuzzy control method applied to quadrotor helicopter stabilization," *NAFIPS 2006-2006 Annual Meeting of the North American Fuzzy Information Processing Society, IEEE, 2006*, pp. 454-458.
- [15] Dierks, Travis, and Sarangapani Jagannathan, "Output feedback control of a quadrotor UAV using neural networks," *IEEE Transactions on Neural Networks*, vol. 21, issue no. 1, 2009, pp. 50-66.
- [16] Aristotelis Kapnopoulos and Alex Alexandridis, "A cooperative particle swarm optimization approach for tuning an MPC-based quadrotor trajectory tracking scheme," *Journal of Aerospace Science and Technology*, Elsevier, vol. 127, pp. 107725, 2022.
- [17] Riether, Fabian, "Agile quadrotor maneuvering using tensor-decomposition-based globally optimal control and onboard visual-inertial estimation," Diss. *Massachusetts Institute of Technology*, 2016.
- [18] A. N. Strahler, "Hypsometric analysis (area-altitude) of erosional topography," *Journal of Geol Soc Am Bull*, vol. 63, pp. 117-142, 1952.
- [19] Ali Sadollah et al., "Water cycle algorithm--A novel metaheuristic optimization method for solving constrained engineering optimization problems," *Journal of Computers & Structures*, Elsevier, vol. 110, pp. 151-166, 2012.
- [20] Ali Sadollah et al., "Water cycle algorithm: a detailed standard code," *Journal of SoftwareX*, Elsevier, vol. 5, pp. 37-43, 2016.
- [21] Eltayeb, Ahmed, et al., "An Improved Design of an Adaptive Sliding Mode Controller for Chattering Attenuation and Trajectory Tracking of the Quadcopter UAV," *IEEE Access*, vol. 8, pp. 205968-205979, 2020
- [22] Dierks, Travis, and Sarangapani Jagannathan, "Output feedback control of a quadrotor UAV using neural networks," *IEEE Transactions on neural networks*, vol. 21, issue no. 1, 2009, pp. 50-66.
- [23] Chen, Fuyang, et al., "Trajectory tracking of a quadrotor with unknown parameters and its fault-tolerant control via sliding mode fault observer," *Proceedings of the Institution of Mechanical Engineers, Part I: Journal of Systems and Control Engineering*, SAGE publication Sage UK, London, England, vol. 229, issue no. 4, 2015, pp. 279-292.
- [24] Voos, Holger, "Nonlinear control of a quadrotor micro-UAV using feedback-linearization." *2009 IEEE International Conference on Mechatronics*, IEEE, 2009, pp. 1-6.
- [25] Mian, Ashfaq Ahmad, and Dao-bo Wang. "Dynamic modeling and nonlinear control strategy for an underactuated quadrotor rotorcraft." *Journal of Zhejiang University-Science A*, vol. 9, issue no. 4, pp.539-545, 2008.
- [26] Pena, M., E. Vivas, and C. Rodriguez, "Simulation of the Quadrotor controlled with LQR with integral effect," *ABCMSymposium Series in Mechatronics*, vol. 5. No. 1, 2012.
- [27] Artale, V., et al., "Dynamic analysis of a hexacopter controlled via LQR-PI," *AIP Conference Proceedings, American Institute of Physics*, vol. 1558. no. 1, 2013, pp. 1212-1215.



Comparative Analysis of LSTM, XGBoost, and Hybrid Approaches in Credit Card Fraud Detection

Ridwan Boya Marqas^{1,2*}, TÜRKER TUNCER¹ and FATİH ÖZYURT¹

¹Software Engineering Department/Firat University, Turkey

²Computer Science Department/Nawroz University, Iraq

*(ridwanmarqas@gmail.com)

Abstract – Credit card fraud is a significant issue in the current economic climate, and it calls for sophisticated detection techniques in order to mitigate the negative effects of this problem. In order to address this issue, the study presented here provides a novel hybrid model that combines Long Short-Term Memory (LSTM) networks with the XGBoost approach. Sophisticated analytical solutions are essential for combating credit card theft due to its secretive nature and complex methods. The hybrid model improves the accuracy of fraud detection by combining the capabilities of LSTM, which are able to distinguish temporal sequences, with the capabilities of XGBoost, which are good in feature learning. With the help of a specific dataset, this research investigates the performance of a hybrid model in comparison to the performance of separate LSTM and XGBoost models. According to the findings, the hybrid model is more effective than the traditional model in identifying fraudulent transactions. The benefits are seen in important performance metrics like (accuracy, precision, recall, and the F1 score). The study's findings show that integrating LSTM and XGBoost into a unified framework is a highly effective approach for addressing financial crime. Specifically, it highlights the significance of utilising hybrid models in the fight against fraudulent use of credit cards.

Keywords – Credit Card Fraud Detection, Hybrid Model, Long Short-Term Memory (LSTM), XGBoost, Machine Learning, Ensemble Techniques

I. INTRODUCTION

Credit card fraud has become a serious economic concern due to the increasing number of digital financial transactions. Fraudulent transactions cause financial losses for individuals and financial organisations and erode consumer trust in the security of electronic payment systems. Fraud is secretive and complex, requiring the creation of improved detection methods that can adjust to changing strategies and reduce possible losses.

Long Short-Term Memory (LSTM) networks have attracted significant attention among the many machine learning techniques. As a specific type of the recurrent neural network, LSTMs are adept at learning from sequences, making them particularly ideal for time-series data frequent in financial transaction logs. XGBoost models are highly praised for their prediction capabilities due to their rapid learning from tabular datasets.

We suggest a hybrid strategy that combines the temporal pattern recognition abilities of LSTM with the feature learning strengths of XGBoost. This model seeks to combine the strengths of both algorithms to improve the identification of fraudulent transactions.

This study aims to install and assess the independent performance of LSTM and XGBoost models on a credit card fraud detection dataset. Additionally, it seeks to create a hybrid model that combines the predictions of these two models. We want to enhance the field by introducing a robust hybrid model and

conducting a comprehensive comparison of performance measures to demonstrate the effectiveness of ensemble techniques in fraud detection scenarios.

II. RELATED WORK

Recent research have highlighted the importance of using advanced machine learning and deep learning approaches in credit card fraud detection to tackle the issues of identifying fraudulent transactions. In [1] showcased the effectiveness of the XGBoost algorithm in detecting credit card fraud, emphasising its capacity to handle skewed datasets, a prevalent challenge in fraud detection situations. While [2] demonstrated the effectiveness of the LSTM algorithm in detecting credit card fraud by highlighting its ability to capture temporal relationships in transaction data. [3] present a comparative analysis of machine learning and concept drift methods, highlighting the evolving nature of fraud detection difficulties and the flexibility needed in detection systems.

In [4] introduced a new method to address imbalanced data in credit card fraud detection. Their strategy combines hybrid neural networks with clustering-based undersampling approaches to improve the identification of minority class cases. Where [5] presented an uncertainty-aware deep learning approach for enhancing the resilience of credit card fraud detection algorithms in uncertain situations. [6] explored the use of ensemble learning methods to tackle issues related to imbalanced and overlapping classes in credit card data. They highlighted the need of using diverse models in ensembles to enhance anomaly detection.

In [7] created a distributed deep neural network model for detecting credit card fraud. The model efficiently handles huge datasets and showcases the capability of distributed computing resources in handling substantial amounts of transaction data. A study of credit card fraud detection approaches within the realm of disruptive technologies, emphasising the changing landscape of fraud detection methods with the emergence of new technologies [8]. In [9] performed a comparative study focusing on machine learning algorithms for balancing uneven credit card fraud detection data. They emphasised the crucial importance of data preparation in developing efficient detection models.

Where [10] studied the autonomy of machine learning techniques in detecting fraudulent uses of credit cards, emphasising the ability of self-learning systems to adapt to new fraud patterns. An improved fraud detection by utilising SVM-recursive feature reduction along with hyper-parameter optimisation, demonstrating the impact of feature selection and model tuning on enhancing detection accuracy [11]. An exploratory investigation on credit card fraud detection utilizing many machine learning techniques to improve the understanding of different models' performance in fraud detection. [12].

researched that use of pipelining and collaborative learning in identifying credit card theft. They suggested an integrated approach that merges many models' benefits to enhance detection accuracy. while conducted a study that compared the Poisson process with machine learning algorithms for identifying credit card scams, offering insights into the advantages of statistical and machine learning methods. Forough and where advocated employing a combination of deep sequential neural networks to solve the nuances of credit card fraud detection, highlighting the benefits of integrating several deep learning models [13]-[15].

III. MATERIALS AND METHOD

A. *Credit Card theft detection Dataset*

The Credit Card Detection Fraud dataset comprises transactions conducted by European cardholders using credit cards in September 2013. The collection contains information on 284,807 transactions during two days, with 492 of them identified as fraudulent. The dataset is very imbalanced, with the advantageous category (frauds) representing only 0.172% of all transactions.

A.A.1 *Dataset Structure*

•Time: The time interval between each operation and the initial transaction in the dataset. It is a form of time estimation that is based on comparison with other periods.

- V1 to V28 represent the principal components derived from PCA. The specific features are kept confidential for privacy purposes. The features have been altered to safeguard confidential data.
- Transaction amount: This functionality is not standardized.
- The class variable represents whether a transaction is fraudulent (1) or non-fraudulent (0).

A.A.2 *Descriptive Statistics*

•The Time feature shows a wide range (from 0 to 172,792 seconds), indicating a continuous monitoring of transactions over the two-day period.

•Principal Components (V1-V28): The PCA-transformed features do not have an easily interpretable scale since they are results of the PCA transformation aimed at reducing dimensionality and preserving variance.

•The Amount variable has a mean of approximately 88.35, but it's highly skewed, as indicated by the large standard deviation (around 250.12) and the max value of 25,691.16, suggesting large transaction amounts are rare but present.

• The dataset exhibits a highly skewed nature, with just 492 (0.172%) fraudulent transactions out of a total of 284,807 transactions.

A.A.3 *Class Distribution*

- Legitimate Transactions (Class = 0): 284,315
- Fraudulent Transactions (Class = 1): 492

B. *Data preprocessing*

Entails identifying and resolving any missing values. Standardize the "Time" and "Amount" attributes to have a mean of 0 and a standard deviation of 1. Apply Principal Component Analysis (PCA) to reduce the dataset's dimensionality while preserving its essential features.

C. *Model Architecture*

LSTM System: Construct a long-short-term memory neural network structure. The LSTM model consists of a single LSTM layer with 64 units, followed by a dense layer of output that uses a sigmoid activation function.

XGBoost Algorithm: Utilise the XGBoost algorithm, a gradient-boosting framework recognised for its effectiveness and high performance in classification problems.

Create a hybrid model by blending the forecasts of the LSTM network and the XGBoost algorithm through a basic averaging method as Figure 1 show.

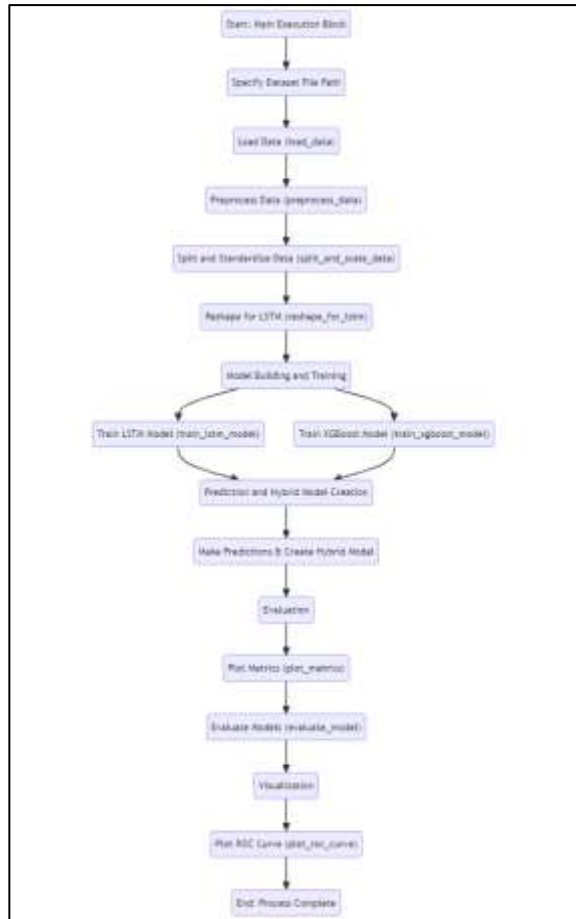

Figure 1. Flowchart of full Proposed Model

D. Training Procedure

Periods of time: Train the LSTM network and the XGBoost algorithm for 20 epochs. Batch Size: Set the batch size to 64 while training the LSTM network. Validation Divided: Allocate 10% of the training information for validation to evaluate the models' efficiency during training.

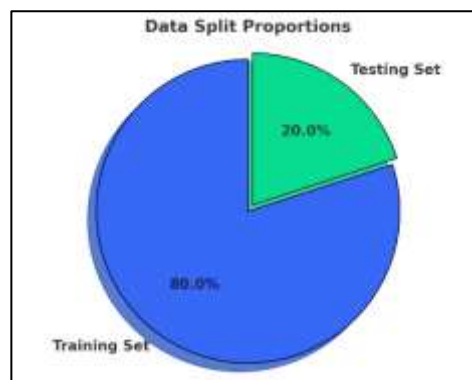

Figure 2. Data Splitting Proportions

Figure 2 displays. The revised graph displays a more sophisticated representation of the data split, showing an 80% training set and a 20% testing set. The visualisation employs an enhanced colour scheme, clear and prominent text, and minor design elements such as a slight expansion of the training set section for emphasis and edge colouring for improved clarity. The chart's aesthetics and design choices aim to simply and efficiently communicate information, making it appropriate for professional reports or presentations.

E. Assessment Criteria

Assess the models using the following metrics:

- Accuracy is a measure that assesses the validity of a model's predictions.
- Precision is the proportion of correct predicted outcomes out of all positive predictions generated by the model.
- Recall is the proportion of correct predicted outcomes to all real positive instances in the dataset.
- The ROC-AUC Score is the area under the Receiver Operating Characteristic (ROC) curve, summarizing the model's performance across various thresholds.

The metrics are suitable for imbalanced datasets as they provide information on the model's performances across both minority and majority classes.

IV. RESULTS

A. Quantitative Results

The LSTM, XGBoost, and hybrid models were quantitatively evaluated, resulting in the following performance measures.

- Long Short-Term Memory Model:

Accuracy rate: 99.95%

ROC The AUC score is 97.60%.

Accuracy: 96%

Remember: 74%

The F1-score is 84%.

- XGBoost Model:

Accuracy rate: 99.96%

ROC The AUC score is 98.11%

Accuracy: 96%

Remember: 78%

The F1-score is 86%.

- Hybrid Model:

Accuracy rate: 99.96%

ROC The AUC score is 98.14%

Accuracy: 97%

Remember: 79%

The F1-score is 87%.

Table 1. Model Training and Validation Metrics Over 20 Epochs

Epoch	Loss	Accuracy	Val. Loss	val. accuracy
1	0.0491	0.9950	0.0030	0.9995
2	0.0030	0.9995	0.0021	0.9996
3	0.0026	0.9995	0.0021	0.9996
4	0.0023	0.9996	0.0019	0.9996
5	0.0021	0.9996	0.0017	0.9996
6	0.0019	0.9996	0.0019	0.9996
7	0.0017	0.9996	0.0018	0.9996
8	0.0016	0.9996	0.0018	0.9996
9	0.0015	0.9997	0.0017	0.9996
10	0.0014	0.9997	0.0018	0.9996
11	0.0013	0.9997	0.0020	0.9996
12	0.0012	0.9997	0.0021	0.9995
13	0.0011	0.9997	0.0022	0.9995
14	0.0011	0.9997	0.0020	0.9996
15	0.000975	0.9997	0.0021	0.9996
16	0.000904	0.9998	0.0022	0.9995
17	0.000797	0.9998	0.0022	0.9996
18	0.000782	0.9998	0.0023	0.9995
19	0.000747	0.9998	0.0022	0.9996
20	0.000659	0.9998	0.0024	0.9995

This table 1 efficiently captures the progression of loss and accuracy over the 20 epochs for both the training and validation datasets, providing a clear overview of the model's performance throughout the training process.

B. Qualitative Results

The learning curves of the LSTM model in Figure 3 show a decreasing loss and rising accuracy over epochs, indicating effective model convergence. The ROC curve analysis in Figure 4 shows the discrimination ability of the models, with the hybrid model outperforming LSTM and XGBoost individually.

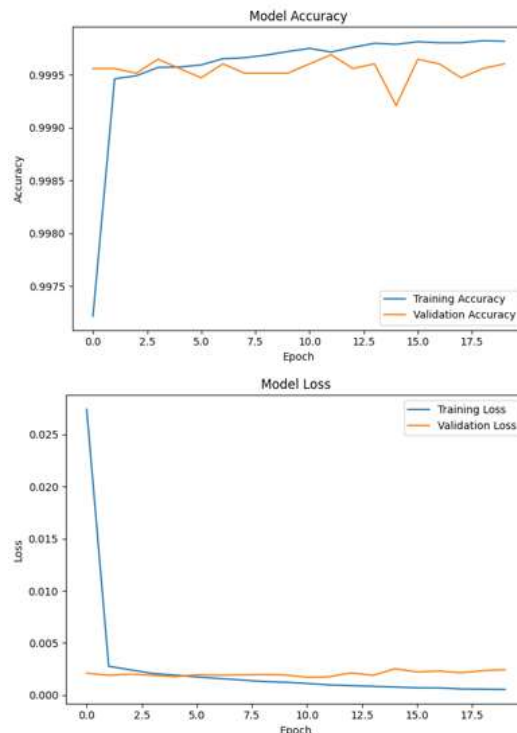

Figure 3. Accuracy and Loss of Model

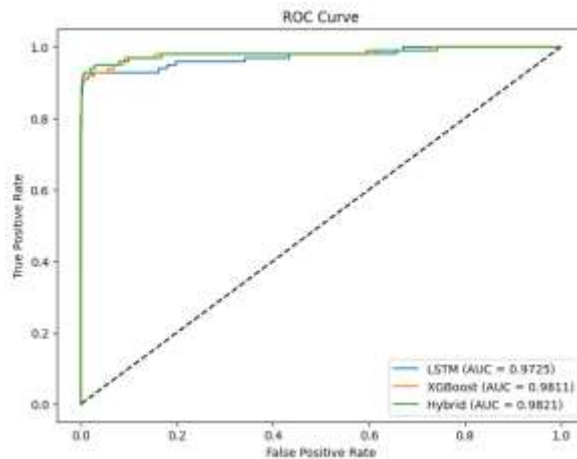

Figure 4. ROC Curve

Figure 4 shows an ROC curve that demonstrates the diagnostic accuracy of binary classifiers in credit card fraud detection. The curve is formed by plotting the True Positive Rate (TPR) versus the False Positive Rate (FPR) at various threshold settings.

Three unique classifiers are being compared:

The LSTM network is a type of recurrent neural network that excels at learning the order dependence in sequence prediction tasks.

The XGBoost model is an ensemble learning technique that utilises the gradient boosting framework, known for its high efficiency and efficacy. A hybrid model that combines the average prediction probabilities from the LSTM and XGBoost models.

The performance of each classifier is represented by the Area Under the Curve (AUC) statistic. The LSTM model achieved an AUC of 0.9725, the XGBoost model achieved an AUC of 0.9811, and the hybrid model achieved an AUC of 0.9821. The AUC is a single numerical value that measures the overall performance of a classifier. A value closer to 1 indicates a higher ability of the model to distinguish between positive and negative classes.

A high true positive rate and a low false positive rate, indicating remarkable classification abilities, are suggested by the curves of each model, which match closely the upper left corner of the picture. The curves in the upper left corner suggest that the models have a high level of discriminative skill in detecting fraud.

The dashed line shows a classifier with no skill, where random predictions would lie, showing an equal probability of false and true positives. The significant difference between the classifiers' ROC curves and the no-skill line confirms their effectiveness.

The ROC curves and AUC values indicate that all three classifiers demonstrate strong predictive performance. The hybrid model performs slightly better than the LSTM and XGBoost models, confirming the effectiveness of the ensemble method in this particular application.

V. DISCUSSION

An analysis comparing the LSTM, XGBoost, and hybrid models indicates that all three models exhibit high accuracy and ROC AUC values, indicating their effectiveness in detecting fraudulent transactions. The hybrid model, combining LSTM and XGBoost predictions, outperforms individual models in

precision, recall, and F1-score, demonstrating its superior fraud detection capabilities. This illustrates how ensemble methods can improve model performance in credit card fraud detection jobs.

Table 2 provides a detailed comparison of the LSTM and Hybrid models based on metrics such as accuracy, ROC AUC score, precision, recall, F1-score, and support for both classes. It showcases the differences and enhancements in the Hybrid model's performance through macro and weighted averages.

Table 2. Evaluation Metrics of LSTM and Hybrid Models

<i>Metric</i>	LSTM Model	Hybrid Model
Accuracy	0.9995	0.9996
ROC AUC Score	0.9748	0.9845
Class 0 Precision	1.00	1.00
Class 0 Recall	1.00	1.00
Class 0 F1-Score	1.00	1.00
Class 0 Support	56864	56864
Class 1 Precision	0.95	1.00
Class 1 Recall	0.78	0.78
Class 1 F1-Score	0.85	0.87
Class 1 Support	98	98
Overall Accuracy	1.00	1.00
Macro Avg Precision	0.97	1.00
Macro Avg Recall	0.89	0.89
Macro Avg F1-Score	0.93	0.94
Weighted Avg Precision	1.00	1.00
Weighted Avg Recall	1.00	1.00
Weighted Avg F1-Score	1.00	1.00
Total Support	56962	56962

VI. CONCLUSION

The study conclusively demonstrates that the hybrid model, incorporating LSTM and XGBoost algorithms, outperforms the standalone models in detecting fraudulent transactions. The hybrid model's superior performance, as evidenced by its higher accuracy, precision, recall, and F1-score measures, validates the effectiveness of integrating different machine learning methods for fraud detection. This work shows how ensemble methods can enhance the predictive accuracy of fraud detection infrastructure, suggesting a promising direction for future research in this field.

ACKNOWLEDGMENT

We are deeply thankful to Assoc. Dr. TÜRKER TUNCER and Assoc. Dr. FATİH ÖZYURT for their essential contributions, guidance, and steadfast support during this project. Their knowledge, insights, and encouragement have been crucial in the completion of this job. Their mentoring, constructive comments, and support in creating a positive research atmosphere have greatly improved the quality and depth of our work. We are grateful for their efforts and dedication, which have significantly impacted our academic and professional development.

REFERENCES

- [1] Mohbey, K. K., Khan, M. Z., & Indian, A. (2022). Credit Card Fraud Prediction Using XGBoost: An Ensemble Learning Approach. *International Journal of Information Retrieval Research (IJIRR)*, 12(2), 1-17. <http://doi.org/10.4018/IJIRR.299940>
- [2] Mohmad, Y. A. (2022). Credit Card Fraud Detection Using LSTM Algorithm. *WJCMS*, 1(3), 26–35. doi: 10.31185/wjcm.60.
- [3] Adebayo, O. S., Favour-Bethy, T. A., Otasowie, O., & Okunola, O. A. (2023). Comparative Review of Credit Card Fraud Detection using Machine Learning and Concept Drift Techniques. *Int. J. Comput. Sci. Mob. Comput*, 12, 24-48.
- [4] Huang, H., Liu, B., Xue, X., Cao, J., & Chen, X. (2024). Imbalanced Credit Card Fraud Detection Data: A Solution Based on Hybrid Neural Network and Clustering-based Undersampling Technique. *Applied Soft Computing*, 111368.

- [5] Habibpour, M., Gharoun, H., Mehdipour, M., Tajally, A., Asgharnezhad, H., Shamsi, A., ... & Nahavandi, S. (2023). Uncertainty-aware credit card fraud detection using deep learning. *Engineering Applications of Artificial Intelligence*, 123, 106248.
- [6] Islam, M. A., Uddin, M. A., Aryal, S., & Stea, G. (2023). An ensemble learning approach for anomaly detection in credit card data with imbalanced and overlapped classes. *Journal of Information Security and Applications*, 78, 103618.
- [7] Lei, Y. T., Ma, C. Q., Ren, Y. S., Chen, X. Q., Narayan, S., & Huynh, A. N. Q. (2023). A distributed deep neural network model for credit card fraud detection. *Finance Research Letters*, 58, 104547.
- [8] Cherif, A., Badhib, A., Ammar, H., Alshehri, S., Kalkatawi, M., & Imine, A. (2023). Credit card fraud detection in the era of disruptive technologies: A systematic review. *Journal of King Saud University-Computer and Information Sciences*, 35(1), 145-174.
- [9] Gupta, P., Varshney, A., Khan, M. R., Ahmed, R., Shuaib, M., & Alam, S. (2023). Unbalanced Credit Card Fraud Detection Data: A Machine Learning-Oriented Comparative Study of Balancing Techniques. *Procedia Computer Science*, 218, 2575-2584.
- [10] Roseline, J. F., Naidu, G. B. S. R., Pandi, V. S., alias Rajasree, S. A., & Mageswari, N. (2022). Autonomous credit card fraud detection using machine learning approach. *Computers and Electrical Engineering*, 102, 108132.
- [11] Rtayli, N., & Enneya, N. (2020). Enhanced credit card fraud detection based on SVM-recursive feature elimination and hyper-parameters optimization. *Journal of Information Security and Applications*, 55, 102596.
- [12] Madhurya, M. J., Gururaj, H. L., Soundarya, B. C., Vidyashree, K. P., & Rajendra, A. B. (2022). Exploratory analysis of credit card fraud detection using machine learning techniques. *Global Transitions Proceedings*, 3(1), 31-37.
- [13] Bagga, S., Goyal, A., Gupta, N., & Goyal, A. (2020). Credit card fraud detection using pipeling and ensemble learning. *Procedia Computer Science*, 173, 104-112.
- [14] Izotova, A., & Valiullin, A. (2021). Comparison of Poisson process and machine learning algorithms approach for credit card fraud detection. *Procedia Computer Science*, 186, 721-726.
- [15] Forough, J., & Momtazi, S. (2021). Ensemble of deep sequential models for credit card fraud detection. *Applied Soft Computing*, 99, 106883.



The organization and functioning of the civil service and public officials in Kosovo - Aspects of the analysis of the new legal basis

Ma Blinera Veliu

¹ College AAB, Prishtina

* blinera.veliu@universitetiaab.com

Abstract – The issue of the concept of public administration in its development and historical evolution emphasizes the necessity of the existence of a functional state apparatus otherwise known as the working locomotive of a state or the nucleus of a state. Facing such a need, state structures today can not be imagined without an administration, whose work over the years, has encountered reorganizations, reforms and developments becoming the essential element to create and maintain trust in government and creating structural reforms to raise the standard of living of society.

The paper seeks to shed light on the efforts of administrative reforms expressed in the laws that regulate the organization and functioning of the state administration in the Republic of Kosovo to highlight the strengths and weaknesses expressed which may create facilities and obstacles for both parties. state power, the first party giving orders and the second party carrying out those orders.

During the elaboration of the matter to reach the necessary analyzes on the new legal basis which deals with the organization and functioning of the state administration in the Republic of Kosovo, a variety of methods have been used, sometimes using them as separate points of view, and sometimes combining them. to create sound analysis to answer research questions raised as well as validate hypotheses.

Keywords – Administration, Law, Organization, Functioning, Implementation

I. INTRODUCTION

The model of organization and operation of the state administration in the Republic of Kosovo is mainly based on the Austrian and German model. The frequent changes that have occurred and continue to occur within the framework of the reform and adaptation of legislation for public administration bodies, which are part of the preparation to be integrated into the family of European Union countries, have determined and will determine changes continuous.

Therefore, it is reasonable to analyze the functioning and organization of the state administration in the Republic of Kosovo, which are based on the legislation for the state administration, that the same legislation has undergone reforms aiming in two basic directions: on the one hand, the reform gives special emphasis on citizens who are parties involved in a direct relationship with the administration, and on the other hand, the importance is placed on the submission of the administration and the power bodies, to the processes of social development whose pace is ever faster. At the same time, public officials are an important factor in the functioning of the state administration, therefore their status and salary system is regulated by laws that have undergone changes over the years.

II. THE LAW ON THE CIVIL SERVICE OF KOSOVO

The rules for the general management and organization of a politically impartial civil service, the rules of admission to it, working conditions, rights and obligations, personal conduct, career advancement and the professional development of civil servants in central institutions, the administration of the Assembly of the Republic of Kosovo, the administration of the Presidency of the Republic of Kosovo, the Office of the

Prime Minister and the Minister, as well as executive, regulatory and independent agencies are determined by the law on the civil service of Kosovo.

Law which is for the Civil Service of the Republic of Kosovo no. 03/L-149 dated 25.06.2010, divides the terminologies on leading positions within the state administration and the most important are: all employees within the central and local level administration who carry out the implementation of policies and respect the rules within the relevant institution relying on the relevant procedures are named as an integral part of the Civil Service. The employee in the public administrative staff based on skills and capacity, who formulates and implements policies and monitors the implementation of administrative regulations and procedures also guarantees their applicability is a civil servant. Individuals who triumph during a transparent competitive process for a position are named meritorious.¹

There are two categories of employees in the Civil Service of the Republic of Kosovo, which are career civil servants whose function is on a permanent basis for the achievement of general institutional objectives and non-career civil servants whose function is for a limited duration of two years, for the achievement of certain projects or the temporary replacement of any career civil servant. Such positions are approved by the government for executive institutions which are proposed by the relevant ministry and approved by the Ministry of Finance.

Any appointment of less than six months will be approved on the basis of the contract type for Special Services Agreement. In the civil service of the Republic of Kosovo, all persons who are citizens of the Republic of Kosovo have the right to be employed, who have the necessary educational preparation, as well as possess civil and political rights and are of legal age.

Senior management officials, in the hierarchy pyramid in the civil service, can be assigned to different positions with equivalent ranks for a certain period of time, but not longer than six months. Civil servants who participate as candidates in the central or municipal elections are placed on special leave without pay one month before the elections until the official certification. In case of non-election, the civil servant has the right to return to his/her place of work within the civil service one week after the announcement of the official results. But a civil servant cannot hold leadership positions within a political party or be politically active.²

III. CIVIL SERVICE OF THE REPUBLIC OF KOSOVO

The civil service of the Republic of Kosovo is composed of civil servants who must be impartial, professional, responsible for the work they perform within the institution where they work and must be selected through an open and transparent competition for everyone.

Recruitment, organization, and promotion in the Civil Service of the Republic of Kosovo is based on the principle of merit, which guarantees that the Civil Service will consist of the best personnel for public administration positions, as well as recognition of the results of civil servants. while exercising their functions.

Employees of the Administration of the Assembly of the Republic of Kosovo, diplomatic and consular personnel as well as administrative personnel sent abroad or employed in the Ministry of Foreign Affairs of the Republic of Kosovo, administrative personnel employed in the judicial and prosecutorial system, civilian personnel employed in the Police of the Republic of Kosovo and in the Security Forces of the Republic of Kosovo, in the Customs and Correctional Service of the Republic of Kosovo are part of the Civil Service of the Republic of Kosovo and all of these have the basis of regulation in this law. Teaching staff of the education system, medical staff of the health system, creators and performers of art, police officers, customs officers, correctional officers and members of the Kosovo Security Forces as well as political appointees and all those who are appointed by political appointees and members of their cabinet,

¹ Assembly of the Republic of Kosovo, Law No. 03/L-149 Law on the Civil Service of the Republic of Kosovo, Official Gazette 72/2010, 2010, article 2 point 3.5

² Assembly of the Republic of Kosovo, Law No. 03/L-149 Law on the Civil Service of the Republic of Kosovo, Official Gazette 72/2010, 2010, article 17 point 3.

based on this law, the status of civil servant does not apply to the mentioned high positions, but is regulated on the basis of the Labor Law or even by special laws, collective agreements or special regulations.³

The work of civil servants is based on a wide range of principles that guarantee legality, non-discrimination, duty to respond to requests, effectiveness and efficiency, responsibility, impartiality and professional independence, transparency, avoidance of conflict of interest, the principle of equal opportunities for communities and gender. Ten percent of the posts within the civil service at the central level must be reserved for communities that are not the majority in the Republic of Kosovo. Based on the principle of merit, the civil service operates with the public announcement of a vacant position, which relies on impartial transparency and with a testing commission, which also guarantees non-discrimination of candidates and guarantees them the right to appeal at the end of the procedure.

The preparation of the internal human resources admission plan is the institution's responsibility. Every position within the Civil Service at the non-management level is open to all interested parties, while for management positions, senior management positions as well as managerial positions, acceptance is made through promotion procedures within the institution of existing civil servants.

Career advancement from a lower functional category/grade to a category/grade within the same functional category is based on the principle of merit, the positive ratio of prior exercise of duty, prior experience is open to all qualified civil servants through competition which we find based on the Anti-Discrimination Law should complement these conditions for it to be permissible: the availability of vacant positions, the fulfillment of all the conditions set for that position, passing the specified minimum time and successfully passing the test, failure of merit, skills and professional competence. Another criterion that must be met by a career civil servant in order to be promoted in rank is that the current job position is not lower than two job ranks from the position announced as vacant, unless otherwise specified in law.

The procedure for career advancement of civil servants is regulated by special by-laws from the Government. Within the civil service system, there is also the possibility of transferring civil servants, which is done through parallel movements of civil servants to another office within the same organization or to another organization in the same functional category and rank, within the central or municipal administration.

Rotation to another office which in itself has the same functional category and rank, but with other duties and temporary movement to another organization outside the civil service of the Republic of Kosovo, the civil servant at his request, of course also approved by his superior he can be temporarily transferred to perform tasks in a special mission, in an international mission, public enterprise or any other public organization, for which certain professional skills and experience are needed.

The suspended status applies during the temporary transfer of the civil servant according to this law. In the event of the absence of a civil servant at work as a result of factors permitted by law, the superior has the right to temporarily replace him/her with another servant if he/she sees that his/her absence opens up and causes difficulties in the performance of work within the institution, in case of non-acceptance of the colleague's replacement, disciplinary measures will be applied, which are considered an obstacle to administrative activity. Refusal to perform administrative functions by a civil servant is allowed in these cases when the civil servant sees that the work assigned to him is detrimental to his interests and legal rights, endangers his health, requires higher qualification or additional training which civil servants do not possess. After refusing the duty or function based on the above-mentioned points, civil servants notify the orderer so that the order or decision can be withdrawn.

In cases where organizations merge or dissolve, all civil servants within them are reassigned to equivalent positions within the central or municipal administration.

The highest functional positions are those positions that require skills and specialized skills, in cases where there are no applications from existing civil servants and when none of the internal candidates meet the criteria for admission, there is the possibility of accepting external candidates.⁴

³ Assembly of the Republic of Kosovo, Law No. 03/L-149 Law on the Civil Service of the Republic of Kosovo, Official Gazette 72/2010, 2010, article 4 point 1

⁴ Assembly of the Republic of Kosovo, Law No. 03/L-149 Law on the Civil Service of the Republic of Kosovo, Official Gazette 72/2010, 2010, article 18 point 6

The employment relationship is established after the successful completion of the admission procedure defined by this law and by-laws and after receiving a letter of appointment within thirty days after the end of the procedure from the relevant institution within the competences of the public administration in which he will find work the new civil servant. In cases where the employment letter is not signed by the new employee as a civil servant within fifteen days, then employment is offered to the candidate who is next in line after the first employee in accordance with the rules and procedures provided by by-laws. Every career civil servant who is accepted is subject to the probationary period of twelve months, the superior decides on the continuation or not of the contract based on the positive performance report as well as the effectiveness shown during the probationary period. The duration of three months of probationary work applies to all non-career Civil Service employees on which the superior decides on the basis of a positive performance report. During the probationary period, the civil servant performs special training for the specific position he will exercise. Probationary work does not apply to positions that are regulated on the basis of professional advancement. When we are faced with not being accepted to work after the end of the probationary period, the right to appeal exists within a period of thirty days, which is presented to the Independent Supervisory Council. Employees who are non-career employees can move to the career employee stage if such a position opens only after receiving positive evaluations in the last two years. There are four divisions of functional categorizations within the organization of personnel who are employed in the Civil Service of the Republic of Kosovo as civil servants of high managerial level, civil servants of management level, civil servants of professional level, civil servants of technical-administrative level, this division which is present in every institution of the central administration.

IV. CIVIL SERVICE ADMINISTRATION

The ministry under whose responsibility is the public administration made the drafting of policies on the civil service and supervises the implementation of the same policies, also proposes legal acts and issues by-laws in the field of the civil service, defines the norms and standards offunctioning within the institutions that are part of the civil service, proposes to the Government policies in the field of salaries and rewards in public administration institutions, development, coordination as well as supervision, training or education of employees in the Civil Service of the Republic of Kosovo .⁵

The interaction with the database of the salary system and the mandatory pension insurance database is part of the unique system of the Central Register of Civil Servants of the Republic of Kosovo. Obtaining information from the personal file and possession of copies of their personal data is allowed by any civil servant. Every work relationship with every public institution is connected electronically with the Central Register of Civil Servants and this register is updated for any possible changes, such data are protected by law.⁶

The independent institution that oversees the legality of management in the civil service is the council. The Kosovo Institute for Public Administration is responsible for the implementation of policies and strategies of training, education and capacity development in Civil Services.⁷

V. ASSESSMENT OF RESULTS AT WORK

At the end of each year, periodically within each institution of the central and municipal administration, the evaluation of the work results of civil servants is carried out, which aims to increase the level of work success within each institution, increase the efficiency during the performance of the work and increase quality of public services. The evaluation made by the supervisor on the work results is based on the achievement of the objectives set during the year.

The evaluation of the work gives results which influence and give effects in the determination of these points: the need for training of individuals and groups of civil servants, the suitability of civil servants for

⁵ Assembly of the Republic of Kosovo, Law No. 03/L-149 Law on the Civil Service of the Republic of Kosovo, Official Gazette 72/2010, 2010, article 32 point 4

⁶ Ibid., Article 8 point 4

⁷ Assembly of the Republic of Kosovo, Law No. 03/L-149 Law on the Civil Service of the Republic of Kosovo, Official Gazette 72/2010, 2010, Article 10

career advancement, the creation of conditions for the conversion of practical work into appointments or dismissals, the existence of conditions for temporary transfer to international duties, the creation of conditions for the granting of special holidays, the continuation or termination of the employment relationship in the civil service. The results of the evaluation of the work of civil servants are placed in the register of human resources and personnel management.

Part of the rights and obligations that belong to civil servants are attending trainings or participating in certain programs outside the civil service, with the sole rationale that these serve to improve the quality of service provision. The working hours for civil servants must not exceed forty hours per week, within which eight hours in a day including a one-hour break and a weekly rest of forty-eight hours.

Pregnant women, mothers who have a child up to the age of three, as well as people with disabilities are not allowed to work the night shift or spend forty hours during the week.

The Law on Civil Servants of the RKS recognizes the right of civil servants to work with reduced hours, which is considered such since the calculation of the weekly or even annual basis is shorter than the working hours of a similar civil servant with a schedule full. Short-time employees are given the opportunity to enjoy the right to receive payment or additional leave for the hours they work outside the hours specified by contract and which is regulated by law.

Annual leave and leave on official holidays are guaranteed to civil servants based on this law and other laws, the minimum duration of annual leave for paid civil servants, which they do not have the right to waive. A maximum of twelve days can be carried over from one calendar year to the following calendar year. Another division on the right to vacations of civil servants is the right to special vacations, which includes medical leave, bereavement leave, parental leave and unpaid leave. Every civil servant, in addition to obligations, also has rights during the performance of work within the institution in which they perform their function, these rights are divided into the right to suitable working conditions, as a result of this right, every body is obliged to guarantee civil servants a safe and suitable environment for the performance of work, the right to equal treatment and equal opportunities for career development involving personnel management, including career, rewards, compensations and legal protection regardless of gender, race, religious affiliation, the duty of the institution of state administration is to guarantee that it will remove all obstacles through which the freedom and full access of every individual with disabilities would be violated. The right to salary is regulated through the law, which guarantees the civil servant monetary compensation for the work performed. The right to keep the workplace and maintain the equivalent position, the right of association, the exercise of political rights, the right to strike, the right to participation and representation in the management bodies of the civil service, the right to appeal. The actions and conditions of the professional behavior of civil servants which are based on obligations which are: the exercise of duty and the obligation to implement the law, the obligation not to abuse authority, the obligation to refuse illegal rewards, the obligation not to give illegal rewards for other civil servants, the obligation to inform and justify administrative actions, the obligation to secrecy and respect for private life, the obligation to facilitate and speed up administrative procedures, the obligation to maintain a high standard of professional work.

All civil servants are obliged to respect the work schedule and use it for the performance of certain tasks. They must account for any absence and receive approval from their superior.⁸

VI. RESPONSIBILITIES OF CIVIL SERVANTS

The daily work of civil servants confronts them with difficult situations that often put them in front of solutions that send them to the point of violating the principles on which they perform their official function. For any violation of the official duty which is caused as a result of the fault of the civil servants, they are punished with disciplinary measures against them, these measures which are taken by the holder or the superior. No disciplinary measure can be initiated for any possible violation until the final decision is taken by the competent court. In the event that the civil servant is found guilty and punished, the competent administrative authorities are obliged to act in accordance with administrative principles and rules by

⁸ Assembly of the Republic of Kosovo, Law No. 03/L-149 Law on the Civil Service of the Republic of Kosovo, Official Gazette 72/2010, 2010, Article 59

ordering the dismissal of the civil servant, if the accused civil servant is found not guilty, then he will return to his workplace and to his file personal information will not be highlighted, or brought under any criminal procedure, and no disciplinary measures will be taken against him.⁹

Disciplinary measures are taken in proportion to the consequences and damages caused, which implies that they are applied gradually. Violation of duty is categorized into light violations and serious-serious violations. For the category of light violations, the disciplinary measures are: oral, written warning that is placed in the civil servant's personal file, while for the category of serious-serious violations, the following measures are: suspension from work and withholding of one third of the monthly salary for two next month, decision taken by the disciplinary commission, after the supervisor's request, dismissal from the office and transfer to another location with similar duties and ban on promotion for up to five years by the disciplinary commission or termination of employment in the Civil Service from the disciplinary committee.¹⁰

The disciplinary commission is a commission established by every public administration institution that employs civil servants and is composed of the latter, who must have superior school training. The chairman and members of the disciplinary commission are appointed by the general secretary of the respective institution, whose mandate is two years with the possibility of extension for another two years. The bylaw regulates the operation and procedures undertaken by the disciplinary commission. The powers of the disciplinary commission are: to listen to the evidence related to the eventual alleged violation, based on the evidence collected, the punishments that must be imposed for the commission of these violations by civil servants are established and determined.¹¹ Disciplinary commissions are not formed only for civil servants, but they are also established for officials in high hierarchical positions. As such these commissions are administered by a special disciplinary commission which in special cases may be established by the Government. This commission consists of five members, of which at least one member must be from the deputy prime minister, the minister responsible for public administration, one member from the minister from among the communities and two members from the general secretaries. It is worth noting that the function of the commission for senior officials does not differ from the function of the commission for civil servants.

For the positions of high officials who are accused of certain violations, not necessarily having committed them, their leader receives as a measure suspension from work with monthly payment, fifty percent of the monthly salary, which the accused, the suspect receives for as long as it will be in suspension, and for which it is immediately reported to the Prime Minister. Another measure could be a reduction in position, or even the immediate termination of the employment relationship.

During the process under investigation, the civil servant, in addition to the obligations and measures taken against him, also has basic rights which are defined by the law as follows: the right to know the accusation and its basis on which it was raised, the right to be heard and to answer, the right to present evidence and the right to access legal aid and appeal, and in detail these rights are regulated by the civil servant by sub-legal act¹².

From the treatment of the relevant articles on disciplinary measures of the Law on Civil Service, it is highlighted that at the beginning of it, the penalties are specified on the civil servants who act and perform their duties in violation of the principles on which they perform their duties, and then the measures are clarified preliminary disciplinary, preventive suspensions and finally the emphasis is placed on how these decisions are made and what are the bodies and procedures that must be followed to take a certain measure. This implies that ambiguities are automatically created by starting the systematization of the measures from the end and not clarifying them chronologically with steps and procedures that come one after the other.

⁹ Ibid., Article 63

¹⁰ Assembly of the Republic of Kosovo, Law No. 03/L-149 Law on the Civil Service of the Republic of Kosovo, Official Gazette 72/2010, 2010, Article 66

¹² Assembly of the Republic of Kosovo, Law No. 03/L-149 Law on the Civil Service of the Republic of Kosovo, Official Gazette 72/2010, 2010, Article 58, 79

VII. SUSPENSION, TERMINATION AND TERMINATION OF EMPLOYMENT IN THE CIVIL SERVICE.

Suspension is a leave, prohibition or interruption from work which is taken in different cases and for different reasons. The cases of suspension are as follows: leave without pay, temporary transfer to other duties inside or outside Kosovo, assuming the office of a public official and performing military obligations, and such suspensions are otherwise known as agreed suspensions. According to the points mentioned above, the civil servant retains the right to return to the previous position after completing the agreed suspension.

Termination of the employment relationship is divided into two levels: termination of the employment relationship due to incapacity to act, which is proven by a certificate from the medical commission, and termination of the employment relationship by unilateral decision, which is done when the institution or civil servant receives initiative to terminate the employment relationship, which can otherwise be called resignation or dismissal from the civil service for the reasons provided by the law on Civil Service. The termination of the employment relationship comes as a result of the creation of conditions and facts regardless of the desire of the civil servant or the relevant institution, which are: reaching the retirement age, permanent disability due to health reasons for the exercise of official duties, the end of the term for employment in cases where the official work was for a certain period of time, punishment by a criminal court with a final decision, for effective imprisonment for six months or even more and in cases of death of the civil servant¹³.

VIII. LAW ON PUBLIC OFFICIALS OF THE REPUBLIC OF KOSOVO

The term public officials in the Republic of Kosovo includes all employees in the public institutions of the Republic of Kosovo based on merit, moral integrity and impartiality and stability, or otherwise Civil Service, Public Service, Cabinet, and administrative and support employees. This implies that this term has replaced and included all public persons who hold public functions in various central or local bodies, civil servants or political officials. A public official is considered any public servant who holds office in a position ranging from professional official to the position of general secretary in the administration of the presidency, the assembly, the office of the prime minister, in the ministry, in an executive agency, in an agency and in a local branch of them, in the administration of institutions of the justice system, in independent institutions or independent agencies, in independent agencies, municipal administration, which implies that this term is comprehensive and on the basis of the law dedicated to public officials, all the ways of operation, organization, management and other situations directly related to functionaries, specifically physical persons who work in public institutions of the Republic of Kosovo. Although this law includes a significant number of physical persons charged with public duties and responsibilities, we also encounter exceptions from the field of law enforcement, which are: public officials and public officials with a special status. The former include elected officials, members of the government and their deputies, as well as officials appointed by the assembly or the presidency, judges and prosecutors, commanding and military personnel of the Kosovo Security Force, officials and the police inspectorate of Kosovo, customs officials and management personnel. and employees of the Kosovo Intelligence Agency, the director or members of the collegial governing body of the regulatory agencies, as well as the personnel of public enterprises owned by the Government or a municipality for which the employment relationship is regulated by labor legislation¹⁴. The second civil servants with a special status are those public servants or officials whose work is also regulated by a special law, this includes professional employees of the diplomatic and correctional service, as well as employees of the administration of the Assembly of the Republic of Kosovo. The very word special status means that these institutions may contain additional or different elements for civil servants outside the law for public officials, and these elements are: special or additional conditions for the recruitment of employees, specific rights or obligations, the rules of special for career development according to the rank system, professional development and training needs, transfer and systematization of employees, as well as regulation by special act on the organizational structure of operation, classification

¹³ Assembly of the Republic of Kosovo, Law No. 03/L-149 Law on the Civil Service of the Republic of Kosovo, Official Gazette 72/2010, 2010, Article 90

¹⁴ Assembly of the Republic of Kosovo, Law No. 06/L-114 Law on Public Officials, Official Gazette 8/2019, 2019 article 3

of positions, working hours which may exceed the limit of the schedule determined by the law on public officials, etc.

IX. PUBLIC OFFICIALS, POSITIONS AND PROMOTION

The Law on Public Officials also regulates the manner and procedures of accepting public officials in public institutions according to which certain conditions must be met which are as follows: to be a citizen of the Republic of Kosovo, to have full ability to act, to master one of the official languages, in accordance with the Law on Languages, be competent in terms of health, not be convicted by a final decision and not have disciplinary measures for removal from an official position in force. Other features that an individual must possess in order to become part of the system of public officials are the following: possess the education and work experience adequate for the required position and successfully pass the admission procedures that are defined by the law on Public Officials in the Republic of Kosovo.¹⁵

At least ten percent of jobs in all categories of public officials in public institutions must be filled with members of the communities, while at the local level the proportion is based on the number of the population. Labor relations within the Civil Service of the Republic of Kosovo are established by the act of appointment, which is for an indefinite period, only in cases where otherwise determined by law. According to the category, class and nature of the position, the Civil Service Law also divided the Civil Service positions as follows:

- Senior management categories, which includes the general secretary, executive director and deputy director of an executive agency as well as equivalent positions.
- Middle management category which consists of: director of the department and the equivalent position.
- Lower management category including: head of division and equivalent position
- The professional category which consists of professional officials.

Each of the aforementioned categories consists of separate work complexes. Acceptance as public officials in the professional category is done through open and public competition, which is organized within each calendar year and which is announced in a term no shorter than 21 days from the date of submission of applications by the responsible unit. The competition takes place in two stages which will be explained as follows: preliminary verification, if the candidate meets the general and special criteria which is carried out by the responsible Unit, the second stage which is done with the evaluation of the knowledge and professional qualities of the candidate which is carried out by the admission committee created by the special unit of the general or special administration for which the competition is held. The test which consists of a total of one hundred points of which twenty points are based on the biography, seventy points from the test and ten points from the oral test, the assessment and results are done electronically and it is ensured that the candidate always remains anonymous. Any candidate who successfully passes all the testing stages has the right to receive the position for which he/she competed. The employee who is appointed for the first time in the Civil Service of the Republic of Kosovo is subject to a probationary period which lasts one year from the time of appointment, which is aimed at the theoretical and practical preparation of the employee to perform the assigned work more successfully, during during the probationary period the civil servant is obliged to participate in trainings and perform official work under the supervision of a civil servant of the same category.

After the end of the probationary period, the institution where the employee is appointed decides on the confirmation of the employment relationship, the extension of the probationary period for another six months or in other cases for non-confirmation of the employee and termination of the employment relationship with the respective institution. The vacant positions of the professional and middle and lower management categories are filled through the internal competition, which is filled with employees of the same category, who meet the criteria to move from one position to another within the institution.¹⁶

¹⁵ Assembly of the Republic of Kosovo, Law No. 06/L-114 Law on Public Officials, Official Gazette 8/2019, 2019 article 8

¹⁶ Assembly of the Republic of Kosovo, Law No. 06/L-114 Law on Public Officials, Official Gazette 8/2019, 2019 article 32, 33,34,35,36,37,38

Promotion for lower and middle management categories is carried out by the Human Resources Unit through a competitive procedure. The evaluation of the candidate is done by an ad hoc evaluation committee established by the senior administrative leader of the institution that has opened a vacancy, the ad hoc committee consists of a representative of the responsible Unit and two representatives of the institution, one of them the head of higher or from a Civil Service institution with special preparation in the selection process and the other from the Human Resources of the institution that has announced a job vacancy. The winning candidate is appointed to the position by the Human Resources Unit of the relevant institution.

For senior management positions, only existing civil servants of the senior or middle management category in the entire Civil Service have the right to compete, the competition is organized by the ministry responsible for public administration for state administration institutions and by the Human Resources Management Unit for any other state institution. The opening of the competitive procedure must be done no shorter than thirty days, before the date set for the submission of applications on the official website. The competition takes place in two phases, which are: the preliminary assessment, through which it is verified whether the candidate meets all the criteria for the given position, which is carried out by the Admissions Unit, as well as the professional assessment, which includes the assessment of professional knowledge, qualities and skills, which is carried out from the admissions committee for senior management positions. The evaluation committee for senior positions, otherwise known as the State Admission Committee, consists of three existing employees with experience in the position of the senior management category and two external experts in the selection process from specialized organizations. Selection of candidates for senior management positions must be made in writing by the immediate supervisor. The selected person is appointed by the Government, the appointment is made for a four-year term with the possibility of re-election for another four years.

X. ADMINISTRATION OF PUBLIC OFFICIALS

The general state policies for the employment of public officials, the by-laws based on the law on Public Officials are approved by the Government of the Republic of Kosovo, which publishes the annual report on the management of human resources of public officials. The Government reports to the Assembly of the Republic of Kosovo with a report on the situation in the civil service by March 31 for each calendar year. Within the Ministry responsible for public administration, the Department for the Management of Public Officials (DMZP) is created and operates and carries the following responsibilities: the preparation and implementation of policies for public officials, the supervision of the implementation of legislation, prepares and supervises the implementation of salary policies, prepares opinion on any draft act proposed by other institutions that deal with employment relations of public officials, approves and supervises the training program organized for public officials, represents the Government together with the Ministry of Finance in negotiations and consultations on the general working conditions of public officials, inspects any file or document related to the working relationships of public officials, administers and maintains the Human Resources Management Information System, supports and provides advice to institutions about the applicability of legislation, prepares general instructions and manuals to guarantee the unified implementation of legislation for public officials, drafts policies for the engagement of interns in the public administration, drafts the general personnel plan, organizes the admission procedure in accordance with the law in force on public officials, drafts the report annual for the management of human resources for public institutions and exercises any powers granted by this law.

Every public institution that internally consists of civil servants is obliged to cooperate with the DMZP. Professional training, capacity development, initial and continuous trainings aimed at the professional development of civil servants, are part of development policies and for the implementation of which the Kosovo Institute for Public Administration (IKAP) is responsible. The Independent Supervisory Council for the Civil Service is an independent body responsible for supervising the work of public officials within the Civil Service of the Republic of Kosovo, which reports to the Assembly of the Republic of Kosovo. Every institution that employs public officials is obliged to establish a Human Resources Management Unit, which is under the direct authority of the highest administrative leader of the respective institution. The

obligation of the Human Resources Management Unit is to keep an annual report on the management of human resources for its institution and by December 31 of the current year to send it for approval to the highest institutional administrative leader.¹⁷

XI. EVALUATION OF RESULTS IN THE WORK OF PUBLIC OFFICIALS

The permanent process is the evaluation of the results in the work of public officials, which includes the evaluation of the achievement of predetermined objectives and the evaluation of the professional behavior of civil servants in the achievement of the objectives set in their work. The evaluation period lasts one year and starts from January 1st and ends on December 30th. Objectives determined individually for employees who are evaluated, which is in accordance with the relevant job description and the objectives of each unit or institution are the constituent parts on which the evaluation of work results for public officials is carried out. At the beginning of each year, the objectives are determined in writing together with the plan of activities for achieving the objectives, which are set by the direct supervisor in cooperation with the employees and with the approval of the latter, the evaluation of each employee is done directly by his supervisor, during in the evaluation process of the work of the public official, meetings are held between the latter and the supervisor in order to review the progress made by the civil servant in achieving the objectives, the supervisor prepares an evaluation report at the end of the evaluation period which is given to the employee and it is discussed in an interview following this step, the step of directly approving the report on the civil servant follows. The evaluation level on the evaluation of the achievement of the employee's objectives can be described as excellent, very good, good, satisfactory or sufficient and unsatisfactory or insufficient. In cases where the evaluation is deemed satisfactory or unsatisfactory, then it is decided that the civil servant attends a mandatory training module, also with such an evaluation, the civil servant cannot compete in closed competitions for promotion or movement within the same category.¹⁸

The non-implementation or improper implementation of the official duty by the civil servant such as: the existence of illegal action or inaction, the performance of the action with fault or inaction, the occurrence of the consequence or damage and the causal connection between the action performed and the consequence-damage puts the civil servant before disciplinary responsibility. Disciplinary violations are divided into: serious and light violations. Serious violations according to this law are defined as non-fulfillment of work duties, non-compliance with the deadline set for the performance of official duties, as a result of which serious consequences are brought, non-implementation of legal provisions and fulfillment of functional duties, benefit in a direct way or indirect gifts, favors from the civil servant to perform a service or favor against the party, abandonment of work or unreasonable absence lasting for five days or more, continuous violation of rules within the institution, failure to preserve classified information as not accessible to the public the use of narcotics or alcohol in the workplace. While the category of light violations includes: unreasonable absence from work for two days, violation of ethics rules, irregular behavior during working hours, performing actions that harm employees, the institution or the entirety of the Civil Service during working hours. Disciplinary measures that are taken against civil servants are: reprimand, ban from twenty to forty percent of the salary for a period of six months, ban on promotion and increase in salary from two to five years, leaving the civil service.

XII. CONCLUSION

By dealing with the laws, we encounter the non-direct description of the characters of the administration, characters which have a legal basis as well as a political one, given that the role is dual. As stated in the law on the organization and operation of the state administration and independent agencies in the Republic of Kosovo of 2019 and the law on Public Officials of the Republic of Kosovo of 2019, which express the importance and participation of the administration in the drafting or creation of policies and their

¹⁷ Assembly of the Republic of Kosovo, Law No. 06/L-114 Law on Public Officials, Official Gazette 8/2019, 2019 article 12, 13, 14

¹⁸ Assembly of the Republic of Kosovo, Law No. 06/L-114 Law on Public Officials, Official Gazette 8/2019, 2019 article 43

implementation. The Law on the Civil Service of 2010 had deficiencies in the division of functional positions within the state administration for civil servants, and it was not arranged in the right way, especially the chapter explaining the punishments that could be applied against civil servants, at first glance it is without clearly as a consequence of the lack of proper order, it first talks about the possibility of what happened if an official is declared guilty by a full decision by the relevant court, and then deals with all the warning options that should be exercised against a civil servant in any institution public. Against the law of 2010, the law on Public Officials of 2019 firstly defines the role, function, duties and rights of a civil servant during the performance of his work, also emphasizes that in every position that only one gender is mentioned, the law foresees and accepts the opposite sex at every hierarchical level within public institutions and removes from use the designation Civil Servant, which is replaced by the designation Public Officials. Likewise, the ranking in the chapter where the consequences that a civil servant bears in cases of misuse of official duty, the categorization of the offense is made in two divisions as serious and minor violations of the official position, and then they explain in detail each procedure which must be followed by the accused official as well as the institution in which the public official committed the damage.

REFERENCES

- [1] Constitution of the Republic of Kosovo, Prishtina, 2008;
- [2] - Assembly of the Republic of Kosovo, Law No. 03/L-149 Law on the Civil Service of the Republic of Kosovo, Official Gazette 72/2010, 2010
- [3] - "Report of the Committee on Instruction in Government," Proceedings of the American Political Science Association, 1913-14" Washington, D.C APSA, 1914
- [4] - Azizi, Abdulla, Etem Aziri, and Zemri Elezi. 2009. Multidimensional Dictionary of Administrative, Political, Social and Diplomacy Terms and Expressions. VATRA, Skopje.
- [5] - Bajram Pollozhani, Esat Stavileci, Ermir Dobjani, Lazim Salihu. "Administrative Law - comparative aspects", ASDRENI, Skopje 2010
- [6] - Batalli, Mirlinda, "Reform of public administration in Kosovo" Thesis, no. 1, 2012
- [7] - Doc. Ballaca. Zejnullah, "The Administrative Right of the RPSSH" - Reprint, 1988.



Design a Robust PID-SMC Controller for Vibration Control of Vehicles

Ayesha Shabbir^{*}, Inam ul Hasan Shaikh², and Ahsan Ali³

¹Department of Electrical Engineering, University of Engineering and Technology Taxila, Pakistan

²Department of Electrical Engineering, University of Engineering and Technology Taxila, Pakistan

³Department of Electrical Engineering, University of Engineering and Technology Taxila, Pakistan

*Ayesha.Shabbir@students.uettaxila.edu.pk

Abstract – This study aims to investigate the operation of an active suspension system in a full car model using an SMC-PID controller. This research employed a dynamic nonlinear model by using 7-DOF. A nonlinear model can be used to represent fundamental vehicle suspension functions such as front and rear wheel suspension, body acceleration, and body displacement. Ride comfort and vehicle handling both affect the performance of the suspension system. It can be measured using the body displacement and body acceleration performance of the car. The simulation is based on the mathematical model and is done using MATLAB software. The outcomes show that body displacement and acceleration performance can be improved by using SMC-PID.

Keywords – sliding mode controller (SMC), degree of freedom (DOF), proportional integral derivative (PID), suspension system, MATLAB, body displacement and acceleration.

I. INTRODUCTION

The standards for a vehicle's performance are rising in parallel with the advancement of science and technology as well as societal improvement. The suspension system is an essential aspect of the vehicle's driving system, and its functionality directly affects the passenger's comfort and safety [1-4]. Consequently, research on active suspension is critical to the growth of the automotive sector and to fulfilling public needs for comfort. An actuator, control unit, and sensors are often included in an active suspension system. For any active suspensions, the control functions as a brain that controls the whole unit. Many academics have been studying active control to attain good results to reach this goal. Different active suspension control strategies, such as optimum control, have been presented to achieve varying performance objectives [5-8]. Vehicle suspension systems are commonly recognized for their ability to protect cars from road-induced vibration and shocks while also ensuring the car's balance by keeping the tires in contact with the road. This feature also contributes to making the ride easier for drivers. Additionally, the active suspension systems can modify the system's power to regulate the vehicle's body motion, maintain tire road holding, lessen the effects of road disturbances, and prevent inappropriate braking and steering operations. As a result, ride quality and comfort can be improved [9]. The fundamental guidelines of a Fuzzy Logic Controller (FLC) for a QCM equipped with an active suspension system are to reduce suspension acceleration and deflection to enhance passenger comfort throughout the ride [10-11].

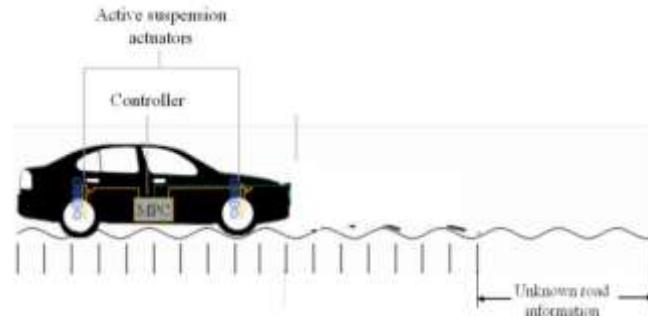

Fig. 1: Active Car Suspension System [13]

The active suspension system uses its own actuator to create actuation forces between the vehicle and tires by adhering to an active control strategy and adaptively generating adjustable suspension control forces, with the smoothness and handling stability of the vehicle. It combines suspension control with vehicle status based on information about the road and vehicle circumstances [12].

The first choice to use in the model while working with the linearized model is the linear control technique. A new technique for active suspension control is developed by combining a proportional-integral-derivative (PID) controller with a fuzzy neural network. The main optimization goal is body acceleration, and the PID controller's parameters are adjusted in real time [14]. Over the past few years, a lot of studies have been done on the resilience and disturbance attenuation of active H_∞ control approaches for automotive suspensions. The weights are fixed and can be chosen to ensure that the hard constraints are achieved. All factors, including those related to hard limitations, are weighted and stated in a single objective function that is minimized to find the optimal controller. A Linear Parameter Varying (LPV) representation is offered in this research study, suggesting that, depending on certain settings, the system the researchers are simulating may operate essentially linearly inside a certain region. This method makes it possible to describe complicated systems with variable dynamics under various circumstances in a more accurate and adaptable manner. In engineering and other disciplines, it is extensively utilized for control theory, system identification, and dynamic system modeling. Such an illustration is typical of semi-active Suspension control methodologies. This method uses a single scheduling parameter to encode the hydraulic actuator's nonlinearities in the LPV representation [15-17]. Robust active damping control method for a quarter car model with three degrees of freedom. The design considers the uncertainty of the parameters of the system. The feedback controllers for the suggested control system were created using linear quadratic regulators (LQR). According to the study's findings, active suspension enhanced the reaction when compared to passive suspension [18].

For mathematical simplicity, automotive suspension systems are frequently described as linear characteristics. However, the behavior of an actual suspension system is nonlinear. Research has been identified in the literature to help explain the nonlinear behavior of automotive suspension systems. [19] Created a model for a nonlinear damper. This model was verified by [20] at frequencies up to 500 Hz. In [21], concentrated on modeling and simulating one degree of freedom dry friction. In actual systems, stochastic disturbances are a prevalent phenomenon. As a result, studies on stochastic control issues have caused a lot of interest and show great potential. [22] created an adaptive fuzzy tracking controller for time-delay systems with stochastic non-linearities. In [25], research was conducted on the issue of adaptive neural intelligent control for nonlinear time-delay systems that are in a measured phase. The suggested fuzzy control method can improve control performance and minimize the chance of chattering occurrences [23]. It is clear for the active suspension system that a robust non-linear controller must be designed using the full optimization problem with an analytical solution and the accompanying in-depth investigations in light of the suspension system's requirements. To accomplish this goal, a new optimal method is used in this study to build a non-linear controller for the car's active suspension system that is accurately robust [24] [26].

The soft connection between the wheel and the body of the car is the suspension system. The suspension system can control and dampen vibrations coming from the pavement. Additionally, the suspension system maintains the vehicle's stability when steering or turning [27-30]. Passive suspension systems, which are

basic mechanical suspension systems, are unable to address issues with vehicle stability and comfort when in motion. Thus, in place of the passive suspension system, the active suspension system has been implemented. A hydraulic actuator is installed in the active suspension system between the sprung and unsprung masses. This system is automatically managed by sensors and an engine control unit [31-32].

There are three types of Suspension systems.

A. Passive Suspension system

A spring and a damper are components of a passive suspension system; the springs absorb energy, and the dampers release it. The spring and damper combination in this class is referred to as a "strut," with the spring positioned parallel to the damper at each corner of the car [33]. A passive control system is a basic control mechanism that operates on car suspension correctly without the need for additional power. It is commonly thought of as the initial approach for controlling vibration in car suspension systems, and numerous studies have been conducted in this area.

B. Semi-active Suspension system

The adjustable damper is what separates semi-active suspension systems from passive suspension systems. This system is capable of providing energy dissipation in real-time, or more accurately, a quick change in the rate of spring damping coefficient. By setting the damper to the desired value, the controller may determine the amount of dampening based on the control method employed.

C. Active Suspension system

A multitude of control actuators that apply force to the suspension in a prescribed manner, or an external power source, are needed for an active control system. Both the addition and dissipation of energy in the suspension may require these forces. For this reason, active control techniques from mechanical and electrical engineering were incorporated into the field of vehicle suspension [34].

II. MATHEMATICAL MODELLING

This section presents the detailed steps to define the mathematical modeling for the quarter and full car model of the suspension system.

A. Quarter Car Model (QCM)

To simulate the dynamic behaviour of a quarter of the vehicle's suspension system, a quarter-car suspension system model must be created.

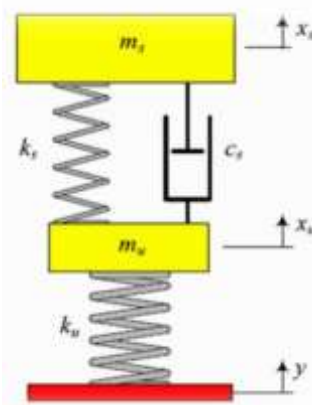

Fig. 2: Quarter Car Model (QCM) [35]

Developing and analyzing this kind of model aims to comprehend how the suspension reacts to different inputs, including disruptions in the road. In Fig. 2, a quarter-car model is composed of two solid masses, referred to as sprung and unsprung masses, respectively, to describe the vertical vibration of a vehicle. The vehicle's body is represented by the sprung mass (m_s), while one wheel is represented by the unsprung

mass (m_u). The sprung mass is supported by a shock absorber with a viscous damping coefficient of c_s and a spring with stiffness k_s . The car's primary suspension is made up of the spring (S) and the damping (D). Through a spring (m_s), which represents the stiffness of the tire, the unsprung mass (m_u) is in direct contact with the ground.

The equations of motion for the quarter-car model shown are:

$$m_s \ddot{x}_s + c_s(\dot{x}_s - \dot{x}_u) + k_s(x_s - x_u) = 0 \quad (1)$$

$$m_u \ddot{x}_u + c_s(\dot{x}_s - \dot{x}_u) + x_u(k_u + k_s) - k_s x_s = k_u y \quad (2)$$

Where the ground excitation is F .

Eq. (1) and Eq. (2) rearranged in matrix form:

$$[m] \ddot{x} + [C_u] \dot{x} + [k]x = F \quad (3)$$

$$\begin{bmatrix} m_s & 0 \\ 0 & m_u \end{bmatrix} \begin{bmatrix} \ddot{x}_s \\ \ddot{x}_u \end{bmatrix} + \begin{bmatrix} C_s & -C_s \\ -C_s & C_s \end{bmatrix} \begin{bmatrix} \dot{x}_s \\ \dot{x}_u \end{bmatrix} + \begin{bmatrix} k_s & -k_s \\ -k_s & k_s + k_u \end{bmatrix} \begin{bmatrix} x_s \\ x_u \end{bmatrix} = \begin{bmatrix} 0 \\ k_u y \end{bmatrix} \quad (4)$$

However, the value of C_u for the tire, compared to the main suspension damping (C_s), is very small, and hence, we may ignore (C_u), to simplify the model.

$$\begin{aligned} m_u \ddot{x}_u &= C_u \dot{x}_u + C_s(\dot{x}_s - \dot{x}_u) + k_u x_u + k_s(x_s - x_u) \\ &= k_u y + C_u \dot{y} \end{aligned} \quad (5)$$

$$m_s \ddot{x}_s = -C_s(\dot{x}_s - \dot{x}_u) - k_s(x_s - x_u) = 0 \quad (6)$$

Any table or figure that takes up more than 1 column width must be positioned either at the top or at the bottom of the page.

B. Full Vehicle Model

An advanced mechanical system called a 7-DOF (Degree of Freedom) active car suspension system has been designed to give cars better handling and ride comfort. A full-vehicle model takes into consideration the vehicle body's displacement, acceleration, and rear and front wheel suspension. A full car model is used significantly to examine the steady-state response which includes smooth to rough road surfaces. There are lateral and vertical forces at each tire contact patch in the full car model's free body diagram.

Figure 3 shows a schematic diagram of a typical full-car model.

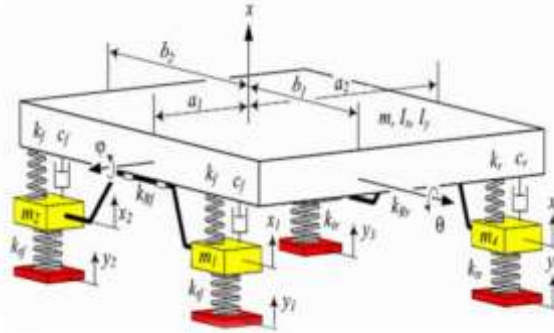

Fig. 3: 7-DOF full vehicle model [35]

The whole car model refers to a vehicle's overall vibrating model.

C. 7-DOF Equations for Full Vehicle Model

The following components are usually taken into account while calculating the seven degrees of freedom: where,

Y_c is the chassis of the car moving vertically

Y_f and Y_r show the vertical movement of the front and rear axles.

θ represents the car's rotation around its longitudinal axis.

ϕ represents the car's rotation around its transverse axis.

δ Shows the angle of rotation of the front wheels.

ω_f represents the front wheels' rotational speed.

ω_r Shows the rear wheels' rotational speed.

The following is a representation of the equations of motion for each degree of freedom [35] [36]:

$$m_c \ddot{Y}_c = -c_1(\dot{Y}_c - \dot{Y}_f) - c_2(Y_c - Y_f) \quad (7)$$

$$-k_1(Y_c - Y_f) - k_2 Y_c + F_{Zs} + F_{Zu}$$

$$m_f \ddot{Y}_f = c_1(\dot{Y}_c - \dot{Y}_f) + c_2(Y_c - Y_f) + k_1(Y_c - Y_f) \quad (8)$$

$$+ k_2 Y_c - F_{Zs} - F_{Zu}$$

$$m_r \ddot{Y}_r = -c_3(\dot{Y}_r - \dot{Y}_c) - c_4(Y_r - Y_c) \quad (9)$$

$$-k_3(Y_r - Y_c) - k_4 Y_r + F_{Zs} + F_{Zu}$$

$$I_p \ddot{\theta} = -l_1(Y_c - Y_r) - l_2 \theta - l_3(\dot{Y}_c - \dot{Y}_r) + M_{Zs} \quad (10)$$

$$+ M_{Zu}$$

$$I_r \ddot{\phi} = -l_4 \phi - l_5(\dot{Y}_c - \dot{Y}_r) + M_{Zs} + M_{Zu} \quad (11)$$

$$I_\delta \ddot{\delta} = -k_\delta \delta + T_\delta \quad (12)$$

$$\omega_f = \frac{T_f}{I_{\omega_f}} \quad ; \quad \omega_r = \frac{T_r}{I_{\omega_r}} \quad (13)$$

In the equations above:

m_c, m_f and m_r are the masses of the chassis, front axle, and rear axle.

c_1, c_2, c_3 and c_4 are damping coefficients.

k_1, k_2, k_3 and k_4 are spring constants.

I_p and I_r are the moments of inertia for pitch and roll.

l_1, l_2, l_3, l_4 and l_5 are lever arm lengths.

M_{Zs} and M_{Zu} are the moments due to external forces applied to the chassis.

I_δ is the moment of inertia of the steering system.

k_δ is the steering stiffness and T_δ is the steering torque.

III. CONTROLLER DESIGN

Combining complicated control algorithms such as SMC-PID can improve the overall performance of the system. In SMC and PID controllers combined for multivariate modeling. Compared to individual control algorithms, integrated algorithms typically produce results of superior quality. Moreover, an active suspension system in a car has been operated by some intelligent control algorithms [37-39]. As previously stated above switching out separate controls for integrated ones is crucial to promoting suspension stability. This will explain how to operate an active suspension system using an advanced control algorithm. The PID and SMC algorithms are used to create this integration algorithm. The component control signals will be combined to create the controller's final control signal. The sensor can provide two different signals that can be used as the input for the SMC and PID controllers. The coefficients are chosen using essential factors for both road holding and riding comfort [40]. The basic block diagram is shown below:

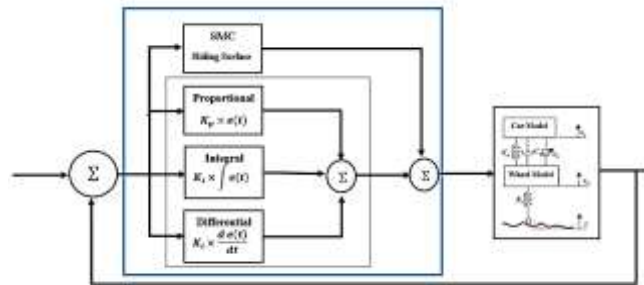

Fig. 4: Block Diagram of Proposed Controller

The combination of the PID controller and sliding mode controller aims to improve the car's vibration control by utilizing the advantages of both control strategies. The PID controller provides precise and stable control, while the sliding mode controller helps handle nonlinearities and disturbances in the system, ensuring robust performance. The enhanced control law of the proposed SMC is derived using the equivalent control law approach and the design of switching control through a Lyapunov stability function in order to address the uncertainties in the system. The proposed SMC is designed by defining a PID control algorithm as sliding surfaces on the dynamic of a second-order car suspension system. First, use SMC-PID to precisely track the desired body movement toward the desired position. After that, to control the body's acceleration, we control the suspension of the front and rear tires. First-order SMC control laws have been used by both controllers.

A. SMC-PID Design

The following equations, which were derived from the system's mathematical modelling, can be used to explain the car suspension system. Consider the separate variable as follows, 7-DOF equations are mentioned in Appendix A. The notation used in the equations, f_r , f_l , r_r , and r_l stands for front-right, front-left, rear-right, and rear-left respectively [41];

$$\dot{x}_i = f_i + g_i u_i \quad (14)$$

where x_i denotes the i^{th} displacement of the wheel,

f_i represents the acting force on the wheel due to external disturbances like road conditions,

g_i is the coefficient for the control input u_i to the x_i displacement.

Assumptions:

I. *The damper and suspension spring stiffness follow linear behaviour.*

II. *The tire is always in contact with the road surface and is approximated by a linear spring with no dampening effect (neglected).*

III. *The vehicle's body is rigid, and neither the tire nor the body can rotate.*

To provide an optimal control effort for every vertical displacement in a full car model, the controller is designed by specifying a difference between the desired and actual trajectory in the following manner:

$$E = e_v = x_{11} - x_{11d} \quad (15)$$

where the system's intended trajectory for a body displacement is indicated as x_{11d}

The error's time derivatives in the above eq. (15) is

$$\dot{E} = \dot{e}_v = \dot{x}_{11} - \dot{x}_{11d} = x_{12} - x_{12d} \quad (16)$$

The PID control algorithm is utilized in the design of the switching or sliding surface.

$$u_{PID} = k_p e + k_i \int e dt + k_d \frac{de}{dt} \quad (17)$$

Therefore, the following defines PID sliding surfaces for body displacement:

$$S = S_v = k_{pv} e_v + k_{iv} \int e_v dt + k_{dv} \dot{e}_v \quad (18)$$

By taking the above eq.18 system uncertainties are included.

$$\dot{S} = \dot{S}_v = k_{pv} \dot{e}_v + k_{iv} e_v + k_{dv} (f_1(x) + \Delta f_1(x)) + k_{dv} (g_1 + \Delta g_1) u_v - k_{dv} \ddot{x}_{11d} \quad (19)$$

For sliding mode, the linear control input is selected as the equivalent.

$$u_{eq} = u_{veq} = (k_{dv} g_1)^{-1} (k_{dv} \ddot{x}_{11d} - k_{dv} f_1(x) - k_{pv} \dot{e}_v - k_{iv} e_v) \quad (20)$$

By specifying

$$\varepsilon_v = k_{dv} \ddot{x}_{11d} - k_{dv} f_1(x) - k_{pv} \dot{e}_v - k_{iv} e_v \quad (30)$$

$$u_{eq} = u_{veq} = (k_{dv} g_1)^{-1} \varepsilon_v \quad (31)$$

It must be appropriately constructed to balance the uncertainties in the system and stabilize the body displacement.

$$u_v = u_{veq} + g_1^{-1}u_{vs} \quad (32)$$

Where g_1 the gain is calculated using equation B in Appendix A.

Considers the Lyapunov stability function as

$$V = \frac{1}{2}S_v^2 \quad (33)$$

Applying the first derivative on Eq. 33,

$$\begin{aligned} \dot{V} &= S_v \dot{S}_v \\ \dot{V} &= S_v [k_{dv} \Delta f_1(x) + k_{dv} u_{vs} + \Delta g_1 (g_1)^{-1} \varepsilon_v \\ &\quad + k_{dv} \Delta g_1 (g_1)^{-1} u_{vs}] \end{aligned} \quad (34)$$

It is now assumed that the upper bounds of the uncertainty are known. Thus,

$$\| \Delta f_1(x) \| \leq \chi_1 \quad (35)$$

$$\| \Delta g_1 (g_1)^{-1} \| \leq \beta_1 < 1 \quad (36)$$

The design parameters χ_1, β_1 , have positive values and are chosen to meet the specified inequalities. Therefore, using Eq. (34) to (36) results in

$$\begin{aligned} \dot{V} &= \| S_v \| (\chi_1 k_{dv} + \beta_1 |\varepsilon_v| + S_v k_{dv} u_{vs} + \| S_v \\ &\quad \| \beta_1 \| u_{vs} \| k_{dv} \end{aligned} \quad (37)$$

After that, the following is the design of the switching control of SMC laws for vertical displacement (u_{vs}).

$$u_{vs} = -\frac{k_{vs}}{1 + \beta_1} \frac{S_v}{\| S_v \| + \delta} \quad (38)$$

IV. RESULTS

A. Body Displacement and Acceleration Response by using the PID Control

The body response of the implemented PID controller is assembled in Table 1 and is shown in Fig. 5. We give a reference of zero, which indicates that the vehicle is comfortable for the passengers. Applying the disturbance to our plant yielded the desired results, with a rising time of 1.29 seconds, a settling time of 0.06 seconds, and a steady state error of nil.

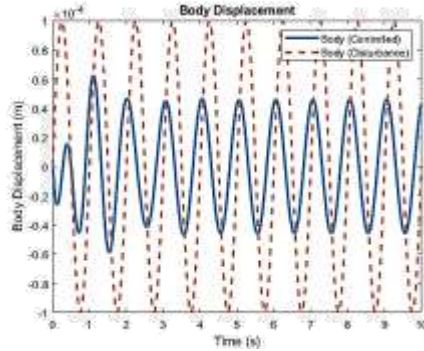

Fig. 5: Body Response of PID Controller

Table 1. Body Displacement Response of PID

Parameter	PID
Rise Time	1.29 s
Settling Time	0.06 s

The body acceleration response by applying the disturbance to our plant yielded the desired results, with a rising time of 0.85 seconds, a settling time of 0.09 seconds, and a steady state error of 0.0003m.

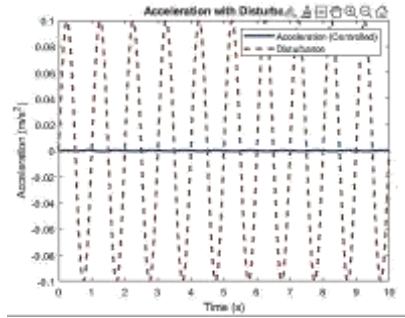

Fig. 6: Body Acceleration Response of PID

Table 2. Body Acceleration Response of PID

Parameter	PID
Rise Time	0.85 s
Settling Time	0.09 s
Steady State Error	0.0003 m

The front and rear wheel suspension are shown in Fig. 7 and Fig. 8, and the results are summarized in Table 3.

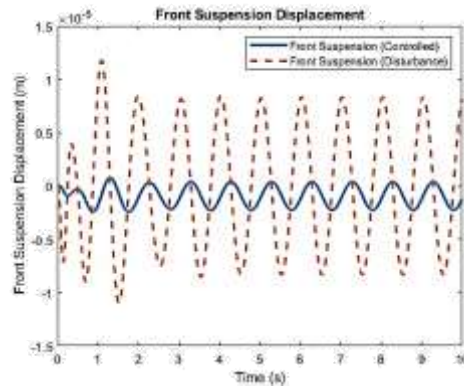

Fig. 7: Front Suspension Displacement

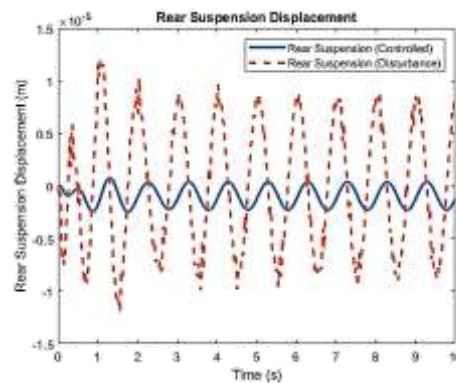

Fig. 8: Rear Suspension Displacement

Table 3: Front and Rear Suspension Displacement

Parameter	Rise Time	Settling Time
Front Suspension	1.18 s	0.05 s
Rear Suspension	1.18 s	0.06 s

B. Body Displacement and Acceleration Response by using the PID-Ziegler Nichols Method

The displacement response of the implemented PID by optimized parameters by using the Ziegler Nichols method the response shows the improvement by rising time of 1.23 seconds, but a little bit of increase in the settling time of 0.11 seconds, and a steady state error of Nil in Fig. 9. The acceleration response is

shown in Fig. 10, which shows the rise time of 0.79 s, the steady-state error is 0.001 m and the settling time is 0.09 s.

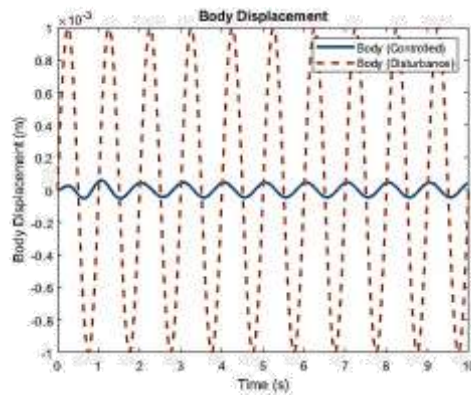

Fig. 9: Body Response by PID-Ziegler Nichols

Table 4. Body Response by PID-Ziegler Nichols

Parameter	PID-ZN
Rise Time	1.23 s
Settling Time	0.11 s

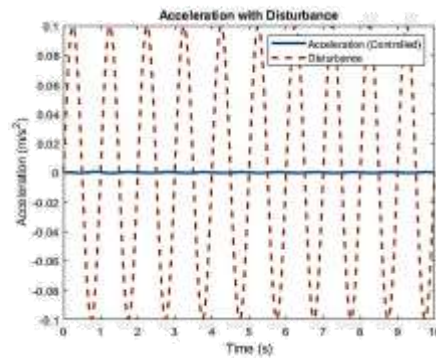

Fig. 10: Body Acceleration Response by PID-Ziegler Nichols

Table 5. Body Acceleration by PID-Ziegler Nichols

Parameter	PID-ZN
Rise Time	0.79 s
Settling Time	0.09 s
Steady State	0.001 m

The front and rear wheel suspension response by using PID-Ziegler Nichols is shown in Fig. 11 and Fig. 12, and the results are summarized in Table 6.

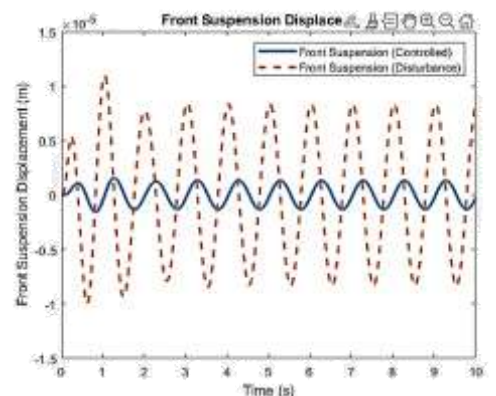

Fig. 11: Front Suspension by PID-ZN

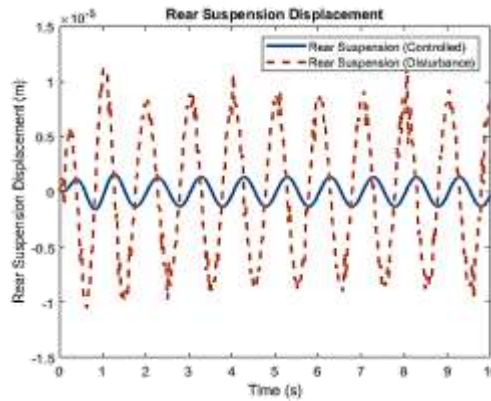

Fig. 12: Rear Suspension by PID-ZN

Table 6: Front and Rear Suspension Displacement

Parameter	Rise Time	Settling Time
Front Suspension	1.22 s	0.10 s
Rear Suspension	1.22 s	0.10 s

C. Body Displacement and Acceleration Response by using the SMC-PID Control

The displacement response of the implemented SMC-PID controller the response shows improvement, in terms of rising time which is 0.33 seconds, settling time of 0.02 seconds, and a steady state error of nil as shown in Fig. 13. The acceleration response is shown in Fig. 14, which shows the rise time of 0.13 s, the steady-state error is 0.0002 and the settling time is 0.03 s.

The front and rear wheel suspension response by using SMC-PID are shown in Fig. 15 and Fig. 16 16, and the results are summarized in Table 9.

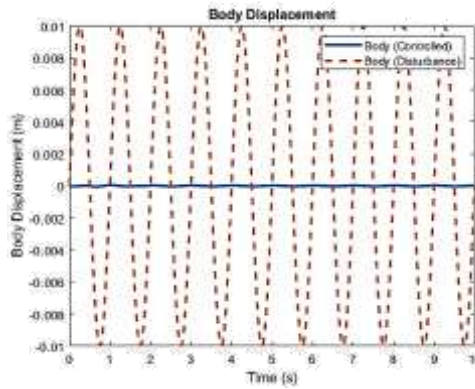

Fig. 13: Body Displacement Response by SMC-PID

Table 7. Body Displacement Response by SMC-PID

Parameter	SMC-PID
Rise Time	0.33 s
Settling Time	0.02 m

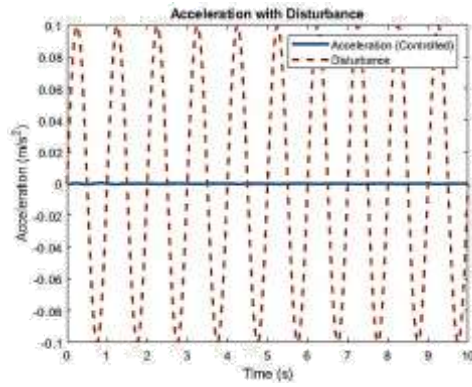

Fig. 14: Body Acceleration Response by SMC-PID

Table 8. Body Acceleration Response by SMC-PID

Parameter	SMC-PID
Rise Time	0.13 s
Settling Time	0.03 s
Steady State	0.0002 m

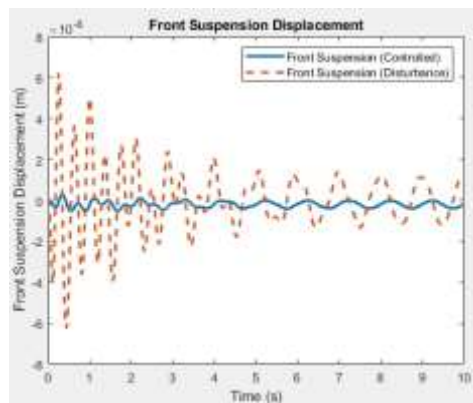

Fig. 15: Front Suspension by SMC-PID

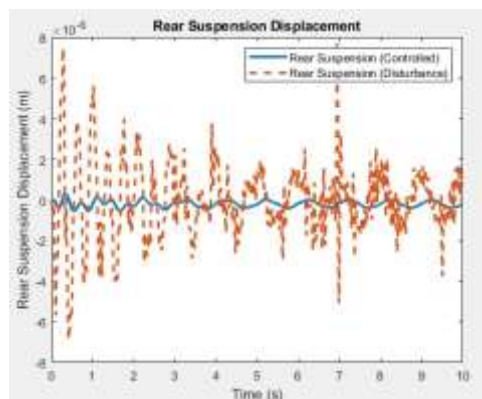

Fig. 16: Rear Suspension by SMC-PID

Table 9: Front and Rear Suspension Response by SMC-PID

Parameter	Rise Time	Settling Time
Front Suspension	0.32 s	0.03 s
Rear Suspension	0.31 s	0.01 s

The analysis's tables make it clear that SMC-PID (Sliding Mode Control-Proportional Integral Derivative) implementation leads to improved performance measures. Of particular, rise time and settling

time about displacement show significant improvements. Additionally, the data shows notable improvements in acceleration dynamics, highlighting the possibility of smoother and more comfortable travel for passengers, particularly when there are outside disruptions. This is especially clear from the graphical representations, where the stabilized parameters successfully lessen the effects of disruptions, making travel more comfortable and stable.

V. DISCUSSION

The present paper examines the PID, the PID using the Ziegler-Nichols approach, and the SMC-PID.

Taking into account Tables 7 and 8. From the comparison table, we can see that our plant's step reaction exhibits efficient outcomes in terms of rise time, settling time, and steady-state error when the SMC is incorporated with our PID controller. The steady-state error for the body displacement reaction is always zero in the case of PID and the SMC-PID. The rise time of the body's acceleration reaction improved from 1.29 to 0.13 seconds. Applying the SMC to the response demonstrates that, in contrast to the single PID controller, our system is capable of handling and resolving road disturbances.

Table 7. Comparison of Body Displacement Response

Parameter	PID	PID-ZN	SMC-PID
Rise Time	1.29 s	1.23 s	0.33 s
Settling Time	0.06 m	0.11 m	0.02 m

Table 8. Comparison of Body Acceleration Response

Parameter	PID	PID-ZN	SMC-PID
Rise Time	0.85 s	0.79 s	0.13 s
Settling Time	0.09 s	0.09 s	0.03 s
Steady State Error	0.0003 m	0.001 m	0.0002 m

VI. CONCLUSION AND FUTURE WORK

To implement the SMC-PID in terms of rise time, settling time, and steady-state error, this thesis compares the PID, PID by Ziegler-Nichols technique, and SMC-PID. The SMC-PID has demonstrated increased performance in terms of rise time, settling time, and steady-state error. This feature greatly enhances the comfort of the passengers' formation travel. Additionally, a MATLAB comparison of PID and SMC-PID under road perturbations is provided. The SMC-PID can reject road disturbances totally, whereas the PID controller cannot reject them.

It is advised that numerous control parameters be adjusted for the next work. For this, an appropriate optimization method must be created and put into practice. The use of sliding mode on the various full-car model setups is an additional factor. A smooth reaching phase can likewise be achieved by implementing a higher-order sliding mode.

REFERENCES

- [1] T. Yoshimura et al., "Construction of an Active Suspension System of a Quarter Car Model using the concept of Sliding Mode Control," *Journal of Sound and Vibration*, Elsevier, vol. 239, no. 2, pp. 187-199, 2001.
- [2] K. Spentzas and S. A. Kanarachos, "Design of a non-linear hybrid car suspension system using neural networks," *Journal of Mathematics and Computers in Simulation*, Elsevier, vol. 60, no. 3-5, pp. 369-378, 2002.
- [3] X. Song, M. Ahmadian, S. Southward and L.R. Miller, "An adaptive semiactive control algorithm for magnetorheological suspension systems," *Journal of Vibration and Acoustics*, vol. 5, pp. 493-502, 2005.
- [4] H. Ren et al., "State observer-based sliding mode control for semi-active hydro-pneumatic suspension," *Journal of Vehicle System Dynamics*, Taylor & Francis, vol. 54, no. 2, pp. 168-190, 2016.
- [5] A. Zaremba, R. Hampo, and D Hrovat, "Optimal active suspension design using constrained optimization," *Journal of Sound and Vibration*, Elsevier, vol. 207, no. 3, pp. 351-364, 1997.
- [6] M. M. ElMadany et al., "Linear quadratic Gaussian control of a quarter-car suspension," *Journal of Vehicle system dynamics*, Taylor & Francis, vol. 32, no. 6, pp. 479-497, 1999.
- [7] Y. Hu et al., "Multiplexed model predictive control for active vehicle suspensions," *International Journal of Controls*, Taylor & Francis, vol. 88, no. 2, pp. 347-363, 2015.

- [8] F. Zhang and W. Wang., "Decentralized control of discrete-Time system with delay in mean field LQR problem," *Journal of Systems Science and Complexity*, Springer, vol. 28, no. 4, pp. 755-772, 2015.
- [9] H. P. Wang et al., "Vibration control of an active vehicle suspension systems using optimized model-free fuzzy logic controller based on time delay estimation," *Journal of Advances in Engineering Software*, Elsevier, vol. 127, pp. 141-149, 2019.
- [10] M. V. C. Ra, and V. Prahlad, "A tunable fuzzy logic controller for vehicle-active suspension systems," *Journal of Fuzzy Sets Syst.*, Elsevier, vol. 85, no. 1, pp. 11–21, 1997.
- [11] B. L. Gysen, T. P. Van Der Sande, J. J. Paulides, and E. A. Lomonova, "Efficiency of a regenerative direct-drive electromagnetic active suspension," *IEEE Trans. Veh. Technol.*, IEEE, vol. 60, no. 4, pp. 1384–1393, 2011.
- [12] C. Hua et al., "Adaptive prescribed performance control of half-car active suspension system with unknown dead-zone input," *Journal of Mechanical Systems and Signal Processing*, Elsevier, vol. 111, pp. 135–148, 2018.
- [13] M. Papadimitrakis and A. Alexandridis, "Active vehicle suspension control using road preview model predictive control and radial basis function networks," *Journal of Applied Soft Computing*, Elsevier, vol. 120, pp. 108646, 2022.
- [14] M. Li, J. Li, G. Li, and J. Xu, "Analysis of Active Suspension Control Based on Improved Fuzzy Neural Network PID," *Journal of World Electric Vehicle*, MDPI, vol. 13, no. 12, pp. 226, 2022.
- [15] M. M. Morato, O. Sename and L. Dugard, "LPV-MPC fault tolerant control of automotive suspension dampers," *Journal of IFAC-Papers Online*, Elsevier, vol. 51, no. 26, pp. 31-36, 2018.
- [16] M. M. Morato, J. E. N. Rico, and O. Sename, "Novel qLPV MPC design with least-squares scheduling prediction," *Journal of IFAC-PapersOnLine*, Elsevier, vol. 52, no. 28, pp. 158-163, 2019.
- [17] M. M. Morato, J. E. N. Rico, and O. Sename, "Sub-optimal recursively feasible Linear Parameter-Varying predictive algorithm for semi-active suspension control," *Journal of IET Control Theory & Applications*, Wiley Online Library, vol. 14, no. 18, pp. 2764-2775, 2020.
- [18] E. Q. Hussien, "Robust Active Damping Design for a Suspension System," *Journal of The Iraqi Mechanical and Material Engineering*, Elsevier, vol. 13, no. 3, 2013.
- [19] S. Duym, R. Stiens and K. Reybrouck, "Evaluation of shock absorber models," *Journal of Vehicle system dynamics*, Taylor & Francis, vol. 27, no. 2, pp. 109-127, 1997.
- [20] V. Y. B. Yung and D. J. Col, "Modelling high-frequency force behavior of hydraulic automotive dampers," *Journal of Vehicle System Dynamics*, Taylor & Francis, vol. 44, no. 1, pp. 1-31, 2006.
- [21] G. J. Stein, R. Zahoransky and P. Mucka, "On dry friction modeling and simulation in kinematically excited oscillatory systems," *Journal of Sound and Vibration*, Elsevier, vol. 311, no. 1-2, pp. 74-96, 2008.
- [22] H. Wang, X. Liu, K. Liu, and H. R. Karim, "Approximation-based adaptive fuzzy tracking control for a class of nonstrict-feedback stochastic nonlinear time-delay systems," *Journal of IEEE Transactions on Fuzzy systems*, IEEE, vol. 23, no. 5, pp. 1746-1760, 2014.
- [23] W. Sun, J. W. Lin, S. F. Su, N. Wang, and M. J. Er, "Reduced adaptive fuzzy decoupling control for lower limb exoskeleton," *Journal of IEEE Transactions on cybernetics*, IEEE, vol. 51, no. 3, pp. 1099-1109, 2020.
- [24] H. Mirzaeinejad and M. Mirzaei, "A novel method for non-linear control of wheel slip in anti-lock braking systems," *Journal of Control Engineering Practice*, Elsevier, vol. 18, no. 8, pp. 918-926, 2010.
- [25] W. H. Chen, D. J. Balance, and P. J. Gawthrop, "Optimal control of nonlinear systems: a predictive control approach," *Journal of Automatica*, Elsevier, vol. 39, no. 4, pp. 633-641, 2003.
- [26] J. J. E. Slotine and W. Li, "Applied Nonlinear Control," Prentice Hall Englewood Cliffs, NJ, vol. 199, no. 1, 1991.
- [27] L. Konieczny and R. Burdzik, "Modern suspension systems for automotive vehicles and their test methods," *Journal of Vibro Engineering Procedia, JVE International Ltd.*, vol. 14, pp. 233-237, 2017.
- [28] S. Narayan, A. S. Alsagri and V. Gupta, "The design and analysis of hybrid automotive suspension system," *Journal of IJMPERD, TJPRC Pvt. Ltd.*, vol. 9, no. 4, pp. 637-642, 2019.
- [29] K. Vijayakrishna, P. R. Sagar, "Robust controller for aircraft yaw," *Journal of IJEEER, TJPRC Pvt. Ltd.*, vol. 4, no. 2, pp. 65-70, 2014.
- [30] A. Agharkakli, G. S. Sabet and A. Barouz, "Simulation and analysis of passive and active suspension system using quarter car model for different road profile," *Journal of International Engineering Trends and Technology*, Citeseer, vol. 3, no. 5, pp. 636-644, 2012.
- [31] A. M. Shirahatti, "Analysis and simulation of active suspension system for full vehicle model subjected to random road profile," *Journal of International Innovative Research in Science*, vol. 4, no. 1, pp. 187-199, 2015.
- [32] F. F. Gnanaraj and K. R. V. Kumar, "Analysis of Vibration Detection using Active Controller in the Smart Cantilever Composite Beam with LQR and Fuzzy Techniques," *Journal of International Mechanical and Production Engineering Research and Development*, vol. 76, no. 8, pp. 67-76, 2018.
- [33] W. Fucheng, "Design and synthesis of active and passive vehicle suspensions, Diss. Ph.D. Thesis, University of Cambridge UK., 2001.
- [34] S. Sarami, "Development and Evaluation of a semi-active suspension system for suspension tractors," M. Sc. Thesis, Berlin, 2009.
- [35] A. AbdulMuhaiman, "Vibrational Analysis and Mathematical Modeling of Vehicle Suspension," M.Sc. Thesis, *Computing and Information Centre*, Czech University of Technology in Prague, 2020.

- [36] D. N. Nguyen and T. A. Nguyen, "A novel hybrid control algorithm sliding mode-PID for the active suspension system with state multivariable," *Journal of Complexity, Hindawi*, vol. 2022, pp. 1-14, 2022.
- [37] A. Hamza and N. B. Yahia, "Heavy trucks with intelligent control of active suspension based on artificial neural networks," *Journal of Systems and Control Engineering, SAGE Publications*, vol. 235, no. 6, pp. 952-969, 2021.
- [38] Q. Meng et al., "Study on vehicle active suspension system control method based on homogeneous domination approach," *Journal of Asian Control, Wiley Online Library*, vol. 23, no. 1, pp. 561-571, 2021.
- [39] J. Sun and K. Zhao, "Adaptive neural network sliding mode control for active suspension systems with electrohydraulic actuator dynamics," *Journal of International Advanced Robotic Systems, SAGE Publications*, vol. 17, no. 4, pp. 1729881420941986, 2020.
- [40] E. Ahmad et al., "Predictive control using active aerodynamic surfaces to improve ride quality of a vehicle," *Journal of Electronics, MDPI*, vol. 9, no. 9, pp. 1463, 2020.
- [41] E. Samsuria, Y. M. Sam and F. Hassan, "Enhanced Sliding Mode Control for a Nonlinear Active Suspension Full Car Model," *Journal of International Robotics and Control Systems*, vol. 1, no. 4, pp. 501-522, 2021.

APPENDIX A

These equations appear to represent a system of equations that model the dynamics of a mechanical system, possibly a vehicle, based on the variables x_1, \dots, x_{16}

$$f_1 = \{ k_{fr}x_1 + k_{fl}x_3 + k_{rr}x_5 + k_{rl}x_9 - (k_{fr} + k_{fl} + k_{rr} + k_{rl})x_{11} - [a(k_{fr} + k_{fl}) - b(k_{rr} + k_{rl})] - \sin(x_{13}) \\ - [d(k_{fl} + k_{rl}) - c(k_{fr} + k_{rr})]\sin(x_{15}) + c_{fr}x_2 + c_{fl}x_4 + c_{rr}x_6 + c_{rl}x_{10} \\ - (c_{fr} + c_{fl} + c_{rr} + c_{rl})x_{12} - [a(c_{fr} + c_{fl}) - b(c_{rr} + c_{rl})] \times \cos(x_{13}) x_{14} - [d(c_{fl} + c_{rl}) \\ - c(c_{fr} + c_{rr})] \cos(x_{15}) x_{16}\}/M \quad (A)$$

$$g_1 = \frac{1}{M} \quad (B)$$

$$f_2 = \cos(x_{13}) \times \{ ak_{fr}x_1 + ak_{fl}x_3 - bk_{rr}x_5 - bk_{rl}x_9 - [a(k_{fr} + k_{fl}) - b(k_{rr} + k_{rl})]x_{11} - [a^2(k_{fr} + k_{fl}) \\ - b^2(k_{rr} + k_{rl})] \times \sin(x_{13}) \\ - [d(ak_{fl} - bk_{rl}) - c(ak_{fr} - bk_{rr})]\sin(x_{15}) + ac_{fr}x_2 + ac_{fl}x_4 - bc_{rr}x_8 - bc_{rl}x_{10} \\ - [a(c_{fr} + c_{fl}) - b(c_{rr} + c_{rl})]x_{12} - [a^2(k_{fr} + k_{fl}) - b^2(k_{rr} + k_{rl})] \cos(x_7) x_8 - [d(ak_{fl} - bk_{rl}) \\ - c(ac_{fr} - bc_{rr})] \cos(x_{15}) x_{16}\}/I_{yy} \quad (C)$$

$$g_2 = \frac{1}{M} \quad (D)$$

$$f_3 = \cos(x_{15}) \times \{ -ck_{fr}x_1 + dk_{fl}x_3 - ck_{rr}x_5 + dk_{rl}x_9 - [d(k_{fl} + k_{rl})] - c(k_{fr} + k_{rr})x_{11} - [d(ak_{fl} - bk_{rl}) \\ - c(ak_{fr} - bk_{rr})] \times \sin(x_{13}) - [d^2(k_{fl} + k_{rl}) - c^2(k_{fr} + k_{rr})]\sin(x_{15}) - cc_{fr}x_2 + dk_{fl}x_4 \\ - cc_{rr}x_6 + dc_{rl}x_{10} - [d(c_{fl} + c_{rl}) - c(c_{fr} + c_{rr})]x_{12} - [d(ac_{fl} - bc_{rl}) \\ - c(ac_{fr} - bc_{rr})] \cos(x_{13}) x_{14} - [d^2(c_{fl} + c_{rl}) - c^2(c_{fr} + c_{rr})] \cos(x_{15}) x_{16}\}/I_{xx} \quad (E)$$

$$g_3 = \frac{1}{M} \quad (F)$$

Table 10. Parameters of 7-DOF Equations with Nomenclature

Parameters	Nomenclature	Value
Mass	M	1500kg
Front and Rear Spring Stiffness	$k_{fr}, k_{fl}, k_{rr}, k_{rl}$	150000 Ns/m
Distance from Centre of gravity to front axle	a,b	1.4m
Distance from Centre of gravity to right side	c	1.5m
Distance from Centre of gravity to left side	d	1.5m
Front and rear damping coefficients	$c_{fr}, c_{fl}, c_{rr}, c_{rl}$	1500 Ns/m
Moment of inertia	I_{yy}, I_{xx}	500kgm ²

Table 11. State Vectors 7-DOF Equation

State Vectors	Definition
x_1	Displacement of Front right unsprung mass
x_2	Velocity of Front right unsprung mass
x_3, x_9	Displacement of Front left unsprung mass
x_4, x_{10}	Velocity of Front left unsprung mass
x_5	Displacement of Rear right unsprung mass
x_6	Velocity of Rear right unsprung mass
x_7	Rear right actuator load pressure
x_8	Rear right Spool Valve position
x_{11}	Sprung mass Heave Displacement
x_{12}	Sprung mass Heave Velocity
x_{13}	Sprung mass Pitch angle
x_{14}	Sprung mass Pitch angle Velocity
x_{15}	Sprung mass Roll angle
x_{16}	Sprung mass Roll angular Velocity



Makine Öğrenmesi Yöntemleri ile Telekomünikasyon Sektörü için Müşteri Kayıp Tahmini

Ezgi GÜL, M. Hanefi CALP

Yönetim Bilişim Sistemleri / İktisadi ve İdari Bilimler Fakültesi, Ankara Hacı Bayram Veli Üniversitesi, Türkiye

gul.ezgi@hbv.edu.tr, hanefi.calp@hbv.edu.tr

Özet - Yüksek rekabet içeren telekomünikasyon sektörü, pazarda varlıklarını sürdürebilmek ve öne çıkabilmek adına yeni aboneler edinme, mevcut abonelerini tutma ve müşteri memnuniyetini sağlama konusunda sürekli çaba göstermektedir. Bu çaba, geleneksel yöntemlerden ziyade makine öğrenmesi yöntemleri ile daha etkin ve verimli bir şekilde sürdürülebilmektedir. Dolayısıyla bu çalışmada, telekomünikasyon şirketlerinin müşteri kayıplarını rakip firmalara karşı önceden tahmin edebilmek amacıyla makine öğrenmesine dayalı bir model geliştirmek amaçlanmıştır. Ayrıca, bu çalışma sadece telekomünikasyon sektörü için değil, genel olarak hizmet sektöründe faaliyet gösteren şirketler için de bir örnek teşkil etmektedir. Makine öğrenmesi tekniklerinin kullanımı, müşteri odaklı iş stratejilerinin belirlenmesi ve uygulanması açısından diğer sektörler için de büyük potansiyele sahiptir. Bu tekniklerin kullanımı, müşteri odaklı iş stratejilerinin belirlenmesi ve uygulanması açısından işletmelere önemli avantajlar sağlayabilir. Dolayısıyla, bu çalışmanın bulguları, birçok endüstriyel alanda rekabet avantajı sağlamak isteyen işletmeler için önemli bir rehberlik kaynağı olabilir. Bu noktada, Yapay Sinir Ağları (YSA), Naive Bayes (NB) ve Lojistik Regresyon (LR) olmak üzere üç farklı yöntem kullanılarak modeller oluşturulmuştur. Önerilen model ile, müşteri kaybına yol açan faktörler belirlenerek şirketlere önemli bir rehberlik sağlanması hedeflenmiştir. Önerilen modelin araştırma amaçları doğrultusunda, açık veri kaynaklarından elde edilen bir veri setinden yararlanılmıştır. Sonuçlar, LR modelinin genel olarak en iyi performansı gösterdiğini ancak diğer modellerin de belirli metriklerde rekabetçi sonuçlar elde ettiğini göstermektedir.

Anahtar Kelimeler: Telekomünikasyon Sektörü, Müşteri Kaybı, Makine Öğrenmesi, Tahmin, Müşteri Davranışları

I. GİRİŞ

Telekomünikasyon sektöründe müşteri kaybı analizi, büyük miktarda veriye dayalı olarak gerçekleştirilen karmaşık bir süreçtir. Bu analiz, müşteri kaybının tahmin edilmesi ve etkili önlemlerin alınabilmesi için önemlidir. Bu noktada, makine öğrenmesi veya veri madenciliği yöntemleri bu analizin temelini oluşturan araçlardır [1].

YSA, karmaşık ilişkileri tanıma yeteneği ile bilinir. Bu algoritma, telekomünikasyon şirketlerinin büyük veri setlerini analiz ederek müşteri davranışlarında gizli kalmış desenleri tespit edebilir. NB, olasılık temelli bir sınıflandırma yöntemi olarak, müşteri kaybını etkileyen faktörleri değerlendirmek ve ilişkilendirmek için kullanılabilir. LR ise bağımlı değişken ile bağımsız değişkenler arasındaki ilişkiyi modelleyerek müşteri kaybını öngörmede etkili bir araç olabilir [2].

Bu çalışma, telekomünikasyon şirketlerinin müşteri kaybını analiz etmek ve önceden tahmin etmek amacıyla YSA, NB ve LR algoritmalarını kullanarak bir model geliştirmeyi hedeflemektedir. Bu

algoritmalar, telekomünikasyon sektöründeki müşteri kaybı analizi için daha spesifik ve etkili bir yaklaşım sunmaktadır.

Geliştirilen model, müşteri kaybına neden olan faktörleri belirleme konusunda şirketlere değerli bir perspektif sunarak rekabet avantajı sağlamayı amaçlamaktadır.

II. İLGİLİ ÇALIŞMALAR

Makine öğrenmesi uygulamaları genellikle mevcut veri ve özel sektöre özgü sorunlar temelinde geliştirilmektedir. Bu bağlamda, telekomünikasyon şirketlerinin veri rezervleri, büyük miktarda detaylı çağrı kayıtları ve müşteri bilgileri gibi değerli verilerle doludur [3]. Bu veri rezervleri, pazarlama stratejileri ve dolandırıcılık tespiti gibi çeşitli uygulamalar için zengin bir kaynak sunmaktadır [4]. Telekomünikasyon şirketleri, müşterilere ait iç ve dış verileri geniş bir bilgi havuzunda depolamaktadır. Sınıflandırma, birleşim kuralı öğrenme, kümeleme ve çok boyutlu ölçekleme gibi çeşitli veri madenciliği teknikleri, bu verilerden anlam çıkarmak için kullanılmaktadır [5]. Özellikle sınıflandırma teknikleri, veri setindeki öğeleri belirli sınıflara atamak için kullanılır. Telekomünikasyon endüstrisinde, müşteri segmentasyonu, profil oluşturma, veri hazırlama ve kümeleme gibi adımlar içeren veri madenciliği süreçleri sıklıkla uygulanır. Müşteri segmentasyonu ve profil oluşturma, müşterileri belirli özelliklere göre gruplara ayırma ve tanımlama işlemlerini içerir [6]. Destek Vektör Makinesi (DVM) tekniği, özellikle müşteri profili ve segmentini birbirine bağlamak için kullanılır. Bu teknik, müşterinin demografik bilgileri temel alınarak müşteri segmentini tahmin etmeye yönelik bir veri madenciliği tekniğidir [7]. Müşteri segmentasyonu ve profil oluşturma süreçleri, günümüz rekabetçi telekomünikasyon ortamında müşterilerle daha iyi ilişkiler kurmak ve onların ihtiyaçlarını anlamak için stratejik öneme sahiptir. Bu süreçler, eldeki tüm bilgileri kullanarak müşteri davranışlarını öngörmeyi amaçlar. Profil oluşturma, segmentasyonun ardından gerçekleştirilen bir süreçtir, müşterilerin kullanım davranışlarını belirleme konusunda değerli bilgiler sağlar [8].

III. MATERYAL VE YÖNTEM

Bu bölümde, öncelikle çalışmada kullanılan YSA, NB ve LR teknikleri ele alınmış, ardından veri setinin elde edilme ve hazırlanma süreci açıklanmış, daha sonra da modelin oluşturulma sürecine odaklanılmıştır. Modelin oluşturulmasında ve analiz sürecinde Orange Data Mining ve Microsoft Office Excel programlarından yararlanılmıştır. Sisteme girdi değeri olarak müşteri kullanım verileri, çağrı detayları veya abonelik bilgileri gibi müşteri ile ilişkilendirilmiş veriler verilmiş ve sonrasında bu veriler üzerinde müşteri kaybetme olasılığı tahmin edilmiştir.

A. Veri seti

Bu çalışmada kullanılan veri seti; telekomünikasyon şirketlerinin müşteri kaybetmesi hakkında çeşitli değişkenleri içermektedir. Bu değişkenler sırasıyla; cinsiyet, yaş, ortaklık, bağlılık, kiralama süresi, telefon, çoklu hat, internet, sözleşme, fatura, ödeme, aylık fiyat ve toplam ödemedir. Çalışma kapsamında, müşteri ayrılma analizi için kullanılacak veriler, açık kaynak bir platform olan Kaagle'dan elde edilmiştir.

Telekomünikasyon şirketinde müşteri ayrılma analizi için veri hazırlama süreci şu adımları içerir:

- Veri Analizi ve Temizleme

Eksik veriler, aykırı değerler gibi veri temizleme işlemleri EXCEL ile gerçekleştirilir.

- Özellik Seçimi

Müşteri ayrılma analizi için etkili olabilecek özellikler seçilir. Abonelik süresi, harcama alışkanlıkları, müşteri hizmetleri etkileşimleri gibi faktörler göz önüne alınabilir.

- Sınıflandırma Modellerinin Oluşturulması

YSA, NB ve LR, gibi modeller kullanılarak müşteri ayrılma olasılıkları tahmin edilir.

- Model Değerlendirmesi

Oluşturulan modeller, test verileri üzerinde değerlendirilir. Modellerin doğruluk, hassasiyet, özgünlük gibi performans metrikleri incelenir.

- Görselleştirme

Elde edilen sonuçlar, çeşitli grafikler ve tablolar aracılığıyla görselleştirilir. Model performansı, sınıflandırma sonuçları, özelliklerin etkisi gibi bilgiler görsel olarak sunulabilir.

Bu süreç, telekomünikasyon şirketinin müşteri ayrılma analizi için veri hazırlama ve modelleme aşamalarını kapsar. Veri setinin özellikleri Tablo 1’de ve örnek veriler ise Tablo 2’de ayrıntılı olarak verilmiştir.

Tablo 1. Veri seti

ID	Cinsiyet	Yaş	Ortaklık	Bağlılık	Kiralama Süresi	Telefon	Çoklu Hat	İnternet	Sözleşme	E-Fatura	Ödeme	Aylık Fiyat	Toplam Ödeme	Ayrılma
7469-LKBCI	erkek	hayır	hayır	hayır	16	evet	yok	Yok	iki yıllık	hayır	Kredi Kartı Otomatik Ödeme	18,95	326,8	hayır
8191-XWSZG	kadın	hayır	hayır	hayır	52	evet	yok	Yok	bir yıllık	hayır	Posta Çek Gönderme	20,65	1022,9	hayır
1680-VDCWW	erkek	hayır	evet	hayır	12	evet	yok	Yok	bir yıllık	hayır	Otomatik Banka Ödemesi	19,8	202,25	hayır
1066-JKSGK	erkek	hayır	hayır	hayır	1	evet	yok	Yok	aydan aya	hayır	Posta Çek Gönderme	20,15	20,15	evet
7310-EGVHZ	erkek	hayır	hayır	hayır	1	evet	yok	Yok	aydan aya	hayır	Otomatik Banka Ödemesi	20,2	20,2	hayır
9867-JCZSP	kadın	hayır	evet	evet	17	evet	yok	Yok	bir yıllık	hayır	Posta Çek Gönderme	20,75	418,25	hayır
3957-SQXML	kadın	hayır	evet	evet	34	evet	evet	Yok	iki yıllık	hayır	Kredi Kartı Otomatik Ödeme	24,95	894,3	hayır
3170-NMYVV	kadın	hayır	evet	evet	50	evet	yok	Yok	iki yıllık	hayır	Otomatik Banka Ödemesi	20,15	930,9	hayır
0731-EBJQB	kadın	hayır	evet	evet	52	evet	yok	Yok	bir yıllık	evet	Online Çek Gönderme	20,4	1090,6	hayır
8028-PNXHQ	erkek	hayır	evet	evet	62	evet	evet	Yok	iki yıllık	evet	Otomatik Banka Ödemesi	24,25	1424,6	hayır
3887-PBQAO	kadın	hayır	evet	evet	45	evet	evet	Yok	bir yıllık	evet	Kredi Kartı Otomatik Ödeme	25,9	1216,6	hayır

Tablo 2. Veri Setinden Örnek Veriler

Girdiler			Çıktı		
Özellik Adı	Tipi	Değer Aralığı	Özellik Adı	Tipi	Değer Aralığı
Cinsiyet	Numerik	Erkek-Kadın	Ayrılma	polinom	Evet-Hayır
Yaş	polinom	Evet-Hayır			
Ortaklık	polinom	Evet-Hayır			
Bağlılık	polinom	Evet-Hayır			
Kiralama Süresi	Numerik	1 Ay - 72 Ay			
Telefon	polinom	Evet-Hayır			
Çoklu Hat	polinom	Yok-Evet			
İnternet	polinom	Fiber optik-DSL-Yok			
Sözleşme	polinom	Aydan aya-Bir yıllık-İki yıllık			
E-Fatura	polinom	Evet-Hayır			
Ödeme	Numerik	Kredi Kartı Otomatik Ödeme-Posta Çek Gönderme-Otomatik Banka Ödemesi-Online Çek Gönderme			
Aylık Fiyat	Numerik	18,25-26,90			
Toplam Ödeme	Numerik	18,80-2006,95			

B. Veri Temizleme

Değişkenler içerisinde yer alan Online Güvenlik, Online Yedekleme, Cihaz Koruma, Teknik Destek, TV Yayını, Film Yayını verilerinin değer aralığı sadece bir değer içerdiği (“yok” değeri içermektedir.) ve sonuca çok fazla etki etmediği için silinmiştir.

C. Algoritma Seçimi

Çalışmada, müşteri kaybı ile ilişkilendirilebilecek çeşitli özellikler (abonelik süresi, hizmet kalitesi, müşteri memnuniyeti, vb.) kullanılarak makine öğrenmesi yöntemleri ile model önerilmiştir. Bu bağlamda, YSA, LR ve NB algoritmaları tercih edilmiştir ve kapsamlı bir analiz gerçekleştirilmiştir.

IV. BULGULAR VE TARTIŞMA

Bu bölümde, oluşturulan modeller ve bu modellerin performans sonuçları verilmiştir. Elde edilen sonuçlar, her bir algoritmanın müşteri kaybı tahmini konusundaki performansını ortaya koymaktadır. NB'in basit ve hızlı bir çözüm sunma yeteneği, LR'ın doğrusallık avantajı ve YSA'nın karmaşık yapıları anlama kabiliyeti göz önüne alınarak bu modellerin bir araya getirilmesi müşteri ayrılma analizinde daha kapsamlı bir bakış açısı sunabileceği düşünülmüştür.

A. YSA

Bu bölümde, YSA modeli Şekil 1'de verilmiş olup elde edilen sonuçlar ve yapılan analizlere yer verilmiştir.

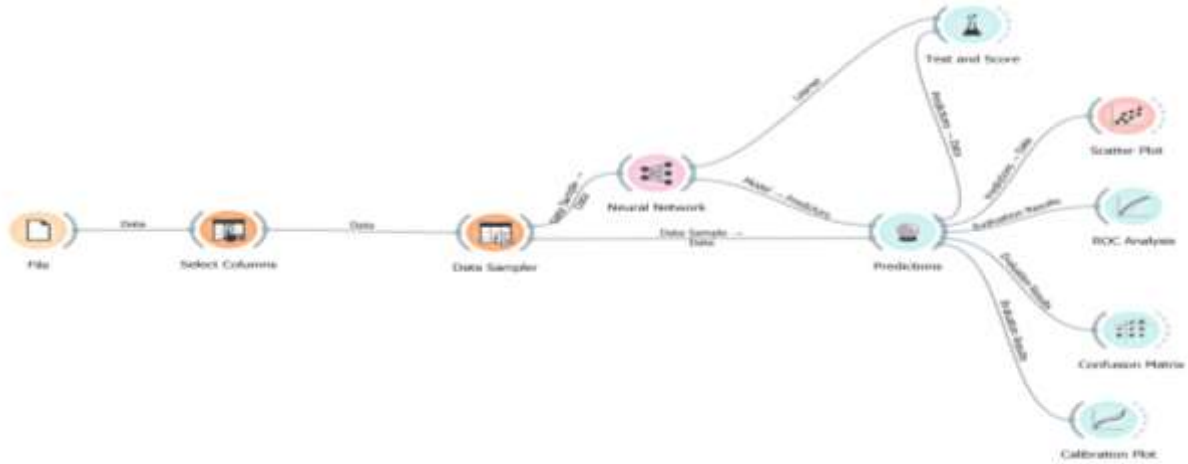

Şekil 1. YSA Modeli

YSA modelinin performansını değerlendiren metriklerin yorumları şu şekildedir:

Tablo 3. YSA model performansı

Model	AUC	CA	F1	Prec	Recall	MCC
Neural Network	0.810	0.783	0.780	0.777	0.783	0.436

AUC değeri, ROC eğrisinin altındaki alanı ifade ederek sınıflandırma modelinin genel performansını ölçer. 0.810 değeri, modelin pozitif ve negatif sınıfları ayırt etme yeteneğinin iyi olduğunu gösterir. Sınıflandırma doğruluğu (CA) 0.783 olarak hesaplanmıştır; bu değer, genel doğru sınıflandırma oranının makul olduğunu gösterir. F1 skoru, hassasiyet ve duyarlılık metriklerinin harmonik ortalamasıdır ve 0.780 değeri, modelin hem hassasiyet hem de duyarlılık açısından dengeli bir performans sergilediğini gösterir. Hassasiyet (precision) 0.777 olarak ölçülmüştür, bu da pozitif tahminlerin çoğunlukla doğru

olduğunu gösterir. Duyarlılık (recall) 0.783 olarak bulunmuştur, bu da pozitif durumları iyi bir şekilde yakaladığını gösterir. MCC değeri 0.436'dır, bu da modelin dengeleme yeteneğini temsil eder, ancak belirli sınıflar arasındaki dengesizlikle başa çıkma konusunda iyileştirmeye ihtiyaç olduğunu gösterir. Genel olarak, sinir ağı modeli iyi bir performans sergilese de bazı metriklerde orta düzeyde değerlere sahiptir. Sonuç olarak, modelin pozitif ve negatif sınıfları belirleme konusunda iyi bir iş çıkardığı ancak yanlış pozitif ve negatif sınıflandırmaların da bulunduğu görülmektedir. YSA modelinin modelinin karmaşıklık matrisi sonuçları Tablo 4'te verilmiştir.

Tablo 4. YSA modelinin karışıklık matrisi

		Predicted		Σ
		evet	hayır	
Actual	evet	1014	316	1330
	hayır	221	3380	3601
Σ		1235	3696	4931

Modelin pozitif (ayrılan) ve negatif (ayrılmayan) sınıfları nasıl tahmin ettiğini gösterir. Yüksek TP ve TN değerleri, modelin genel doğru sınıflandırma yeteneğini gösterir. FP ve FN değerleri, yanlış sınıflandırmaları temsil eder. Model, genel olarak pozitif sınıfları belirleme konusunda iyi bir iş çıkarmıştır, ancak yanlış pozitif ve negatifler de bulunmaktadır. YSA modelinin ROC analiz grafiği;

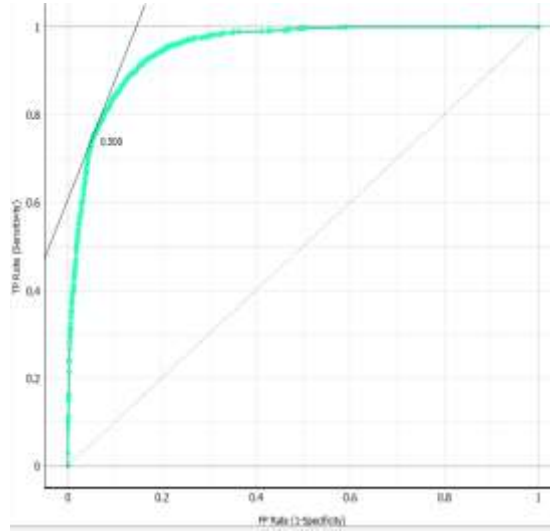

Şekil 2. YSA modelinin ROC analiz grafiği

Tablo 5. YSA modelinin tahmin performansı

error	AYRILMA	ID	Cinsiyet	Yaşı	Ortalık	Bağlılık	Kinola Süresi	Telefon	Çıdu Hat	İnternet	Online Güvenlik	Online Yedekleme	Gizli Konuma	Teknik Destek	TV Yayın	Film Yayın
0.88 - 0.11 - evet 0.106	evet	1024-GUNLD	kadın	hayır	evet	hayır	1	yok	yok	DSL	yok	yok	yok	yok	yok	yok
0.00 - 1.00 - hayır 0.003	hayır	0484-İBRUJ	erkek	hayır	hayır	hayır	41	evet	evet	Yok	yok	yok	yok	yok	yok	yok
0.00 - 1.00 - hayır 0.001	hayır	3633-DHVGZ	kadın	hayır	evet	evet	52	evet	yok	Yok	yok	yok	yok	yok	yok	yok
0.79 - 0.21 - evet 0.211	evet	6932-HADCM	kadın	hayır	hayır	hayır	1	evet	yok	Fiber Optik	yok	yok	var	yok	yok	yok
0.02 - 0.98 - hayır 0.018	hayır	8507-KYZSF	erkek	hayır	hayır	hayır	67	evet	yok	DSL	yok	yok	yok	var	yok	yok
0.70 - 0.30 - evet 0.297	evet	6878-WOBHU	kadın	evet	evet	hayır	68	evet	evet	Fiber Optik	yok	var	yok	yok	yok	var
0.04 - 0.96 - hayır 0.037	hayır	4737-AQCFU	erkek	hayır	evet	evet	72	evet	evet	DSL	var	var	var	var	yok	yok
0.26 - 0.74 - hayır 0.738	evet	5766-ZYTB	erkek	hayır	hayır	hayır	1	evet	yok	Yok	yok	yok	yok	yok	yok	yok
0.26 - 0.74 - hayır 0.263	hayır	3668-TZSPS	erkek	hayır	hayır	hayır	1	evet	yok	Yok	yok	yok	yok	yok	yok	yok
0.08 - 0.91 - hayır 0.085	hayır	5113-CKEQK	erkek	evet	evet	evet	28	evet	evet	DSL	yok	yok	yok	yok	yok	yok

B. NB

Bu bölümde, NB modeli Şekil 3'te verilmiş olup elde edilen sonuçlar ve yapılan analizlere yer verilmiştir.



Şekil 3. NB Modeli

NB modelinin performansını değerlendiren metrikler (Tablo 6) ve yorumları şu şekildedir:

Tablo 6. NB model performansı

Model	AUC	CA	F1	Prec	Recall	MCC
NB	0.836	0.780	0.785	0.795	0.780	0.469

NB modelinin performansını değerlendiren metrikler, çeşitli ölçümler aracılığıyla analiz edilmiştir. AUC değeri 0.836 olarak ölçülmüş ve modelin genel performansının iyi olduğunu göstermiştir. Ancak, bu değer diğer modellere kıyasla bir miktar daha düşük olabilir. Sınıflandırma doğruluğu (CA) 0.780 olarak belirlenmiştir, bu da genel doğru sınıflandırma oranının makul olduğunu gösterirken, diğer metriklere göre bir miktar düşük olabilir. F1 skoru 0.785 olarak hesaplanmış ve modelin hem hassasiyet hem de duyarlılık açısından orta düzeyde bir denge sağladığını göstermiştir. Hassasiyet (precision) değeri 0.795 olarak belirlenmiş, pozitif tahminlerin çoğunlukla doğru olduğunu işaret etmiştir. Duyarlılık (recall) ise 0.780 olarak ölçülmüş, pozitif durumları orta düzeyde yakaladığını göstermiştir. MCC değeri 0.496 olarak hesaplanmış, modelin dengeleme yeteneğini temsil etmiştir ve orta düzeyde bir başarı gösterdiğini belirtmiştir. Bu değerlendirmeler, NB modelinin genel olarak iyi bir performans sergilediğini, ancak diğer modellerle karşılaştırıldığında bazı metriklerde bir miktar düşük değerlere sahip olduğunu göstermektedir. Sonuç olarak, bu metrikler modelin güçlü ve zayıf yönlerini belirlemekte ve geliştirme potansiyeli olan alanları tanımlamaktadır. NB modelinin karmaşıklık matrisi sonuçları Tablo7'de verilmiştir.

Tablo 7. NB modelinin karışıklık matrisi

		Predicted		Σ
		evet	hayır	
Actual	evet	1262	598	1860
	hayır	943	4237	5180
Σ		2205	4835	7040

NB modelinin karmaşıklık matrisi, modelin performansını daha detaylı bir şekilde gösterir. Model, genel doğru sınıflandırma oranında iyi bir performans sergilese de FP ve FN değerleri, modelin hala iyileştirilebilecek yanlış sınıflandırmalara sahip olduğunu gösterir. NB modelinin ROC analiz grafiği Şekil 4’te verilmiştir.

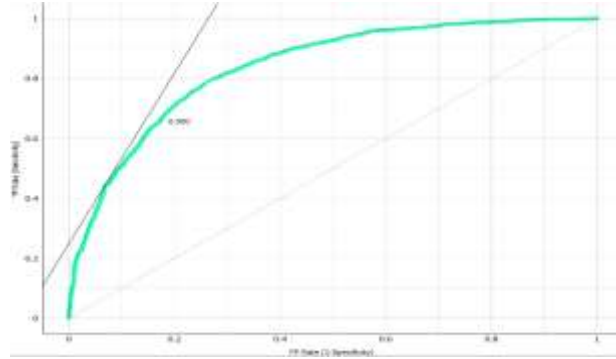

Şekil 4. NB modelinin ROC analiz grafiği

Tablo 8. NB modelinin tahmin performansı

	Naive Bayes	error	AYRILMA	ID	Naive Bayes	Naive Bayes leveli	Naive Bayes (haya)	Fold	Cinsiyet	Yaşı	Ortaklık	Başlık	Kiralama Süresi	Telefon	Çoklu Hat	İnternet	Sosyaleme	E-fatura
1	0.00 : 1.00 → haya	0.001	haya	5543-EJRDZ	haya	0.00147948	0.9985201	1	erkek	haya	evet	evet	64	evet	evet	DSL	iki yıllık	evet
2	0.00 : 1.00 → haya	0.002	haya	6839-QP00Q	haya	0.00243156	0.9975682	1	kadın	haya	evet	evet	72	evet	evet	Fiber Optik	iki yıllık	evet
3	0.00 : 1.00 → haya	0.002	haya	3003-ORMKK	haya	0.00177715	0.9982227	1	kadın	haya	evet	evet	15	evet	evet	Yok	bir yıllık	haya
4	0.99 : 0.01 → evet	0.011	evet	3797-SV0BU	evet	0.9868995	0.01310045	1	erkek	haya	haya	haya	1	evet	evet	Fiber Optik	aydan aya	evet
5	0.11 : 0.89 → haya	0.109	haya	4026-UMZZD	haya	0.126261	0.8737389	1	kadın	haya	evet	haya	31	evet	evet	DSL	aydan aya	evet
6	0.00 : 1.00 → haya	0.002	haya	5989-AJPUJ	haya	0.00285272	0.9971472	1	kadın	haya	evet	haya	68	evet	evet	Fiber Optik	iki yıllık	haya
7	0.08 : 0.92 → haya	0.076	haya	6735-UIEG	haya	0.0758053	0.9241945	1	erkek	haya	evet	haya	14	evet	evet	DSL	aydan aya	haya
8	0.44 : 0.56 → haya	0.563	evet	7734-CBOW	haya	0.436765	0.563235	1	kadın	haya	evet	evet	1	evet	evet	DSL	aydan aya	haya
9	0.00 : 1.00 → haya	0.001	haya	2193-SF0CW	haya	0.000749136	0.9992501	1	erkek	haya	evet	evet	72	evet	evet	Fiber Optik	iki yıllık	haya
10	0.63 : 0.17 → evet	0.173	evet	4197-AJFYK	evet	0.819694	0.180306	1	kadın	haya	haya	evet	1	evet	evet	DSL	aydan aya	evet

C. LR

Bu bölümde, LR modeli Şekil 5’de verilmiş olup elde edilen sonuçlar ve yapılan analizler verilmiştir.

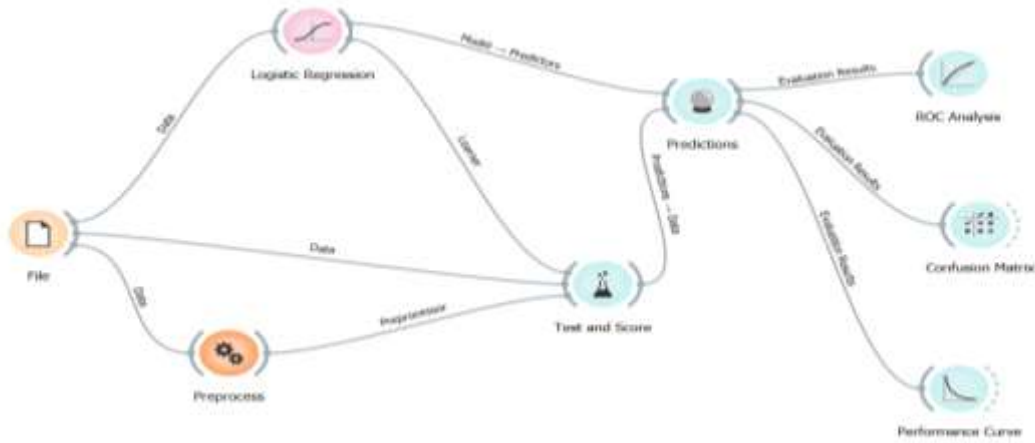

Şekil 5. LR Modeli

LR modelinin performansını değerlendiren bu metrikler, modelin belirli yönlerinin anlaşılmasına yardımcı olabilir. Tablo 9’da her bir metrik değerleri ve ilgili yorumlar verilmiştir.

Tablo 9. LR model performansı

Model	AUC	CA	F1	Prec	Recall	MCC
Logistic Regression	0.845	0.805	0.798	0.796	0.805	0.470

Modelden elde edilen değerler incelendiğinde, sınıflandırma modelinin genel performansını ölçen AUC (Area Under the Curve) değeri 0.845 olup 1'e yakınlığı nedeniyle sınıflandırma yeteneğinin iyi olduğu söylenebilir. CA (Classification Accuracy) değeri 0.805 olup sınıflandırma doğruluğunun iyi olduğunu gösterir. F1 değeri 0.795 olup modelin hem hassasiyet hem de duyarlılık açısından dengeli bir performans sergilediğini gösterir. Precision (Hassasiyet) değeri 0.796 olup pozitif tahminlerin çoğunlukla doğru olduğunu gösterir. Recall (Duyarlılık) değeri 0.805 olup pozitif durumları iyi bir şekilde yakaladığını gösterir. MCC (Matthews Correlation Coefficient) değeri 0.470 olup modelin dengeleme yeteneğini temsil eder. 0'a ne kadar yakınsa, modelin dengeleme yeteneği o kadar iyidir. Bu noktada modelin diğerlerine nazaran iyi ancak genel anlamda çok da iyi olduğu söylenemez. LR modelinin karışıklık matrisi sonuçları Tablo 10’da verilmiştir.

Tablo 10. LR modelinin karışıklık matrisi

		Predicted		Σ
		evet	hayır	
Actual	evet	982	878	1860
	hayır	502	4678	5180
Σ		1484	5556	7040

"Evet" sınıfı için True Positive (TP) sayısı 982, bu da modelin "Evet" sınıfını doğru bir şekilde tahmin ettiği durumları gösterir."Hayır" sınıfı için True Negative (TN) sayısı 4678, modelin "Hayır" sınıfını doğru bir şekilde tahmin ettiği durumları gösterir.Evet sınıfı için False Positive (FP) sayısı 878, yanlış pozitif tahmin sayısını temsil eder. Hayır sınıfı için False Negative (FN) sayısı 502, yanlış negatif tahmin sayısını temsil eder.

Şekil 6’da, LR modelinin ROC analiz grafiği verilmiştir.

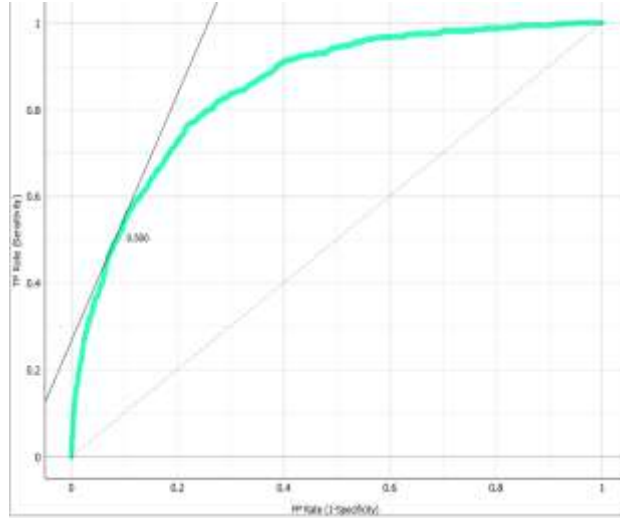

Şekil 6. LR modelinin ROC analiz grafiği

Tablo 11. LR modelinin tahmin performansı

	Logistic Regression	error	AYRILMA	ID	Logistic Regression	Logistic Regression (evet)	Logistic Regression (hayır)	Fold	Cinsiyet	Yaşı	Ortalık	Bağlılık	Kiralama Süresi	Telefon	Çoklu Hat	İnternet
1	0.05 - 0.95 → hayır	0.050	hayır	5383-EDDZD	hayır	0.0141815	0.965818	1	erkek	hayır	evet	evet	44	yok	yok	DSL
2	0.05 - 0.92 → hayır	0.063	hayır	6059-QNQQ	hayır	0.0646812	0.935319	1	kadın	hayır	evet	evet	72	evet	evet	Fiber Optik
3	0.05 - 0.95 → hayır	0.046	hayır	5003-CKZNK	hayır	0.049579	0.950421	1	kadın	hayır	evet	evet	15	evet	yok	Yok
4	0.75 - 0.23 → evet	0.251	evet	9787-XVQJL	evet	0.758375	0.241625	1	erkek	hayır	hayır	hayır	1	evet	evet	Fiber Optik
5	0.15 - 0.87 → hayır	0.133	hayır	4826-UMJZD	hayır	0.141179	0.858821	1	kadın	hayır	evet	hayır	31	evet	yok	DSL
6	0.07 - 0.93 → hayır	0.074	hayır	5089-AMFUC	hayır	0.0603658	0.939634	1	kadın	hayır	evet	hayır	68	evet	evet	Fiber Optik
7	0.19 - 0.81 → hayır	0.190	hayır	8735-LLBEG	hayır	0.18255	0.81745	1	erkek	hayır	evet	hayır	14	evet	yok	DSL
8	0.58 - 0.42 → evet	0.423	evet	7734-DIBCAJ	evet	0.520575	0.479425	1	kadın	hayır	evet	evet	1	yok	yok	DSL
9	0.05 - 0.95 → hayır	0.045	hayır	2193-SPWQW	hayır	0.0326486	0.967351	1	erkek	hayır	evet	evet	72	evet	yok	Fiber Optik
10	0.49 - 0.51 → hayır	0.508	evet	4797-AMPYL	hayır	0.480069	0.551931	1	kadın	hayır	hayır	evet	1	evet	yok	DSL

V. SONUÇLAR

Çalışmada, telekomünikasyon şirketlerinin müşteri kaybı tahmin edilmiş, elde edilen sonuçlar analiz edilmiş ve bu sonuçlar dikkate alınarak müşteri sadakatini artırmaya yönelik öneriler sunulmuştur. Çalışmada elde edilen sonuçlar, her bir algoritmanın müşteri kaybı tahmini konusundaki performansını ortaya koymaktadır. NB'in basit ve hızlı bir çözüm sunma yeteneği, LR'ın doğrusallık avantajı ve Neural Network'ün karmaşık yapıları anlama kabiliyeti göz önüne alınarak, bu modellerin bir araya getirilmesi müşteri ayrılma analizinde daha kapsamlı bir bakış açısı sunabileceği düşünülmüştür. Telekomünikasyon sektöründe makine öğrenmesi, müşteri kayıp tahmini modelleri oluşturarak müşteri sadakatini artırmak ve müşteri ayrılma riskini öngörmek amacıyla önemli bir araç olduğu görülmüştür.

Analiz sonuçları, telekomünikasyon şirketlerine, müşteri kaybını önceden tahmin etmek ve müşteri ayrılma oranını minimize etmek için stratejiler geliştirmede değerli bilgiler sunmaktadır. Bu tür veri madenciliği projeleri, müşteri odaklı stratejiler oluşturarak şirketlerin rekabet avantajını artırmalarına yardımcı olabilir.

Bu bağlamda, her bir modelin avantajları ve zayıflıkları göz önüne alındığında, seçilecek modelin spesifik gereksinimlere ve önceliklere bağlı olduğu söylenebilir. Bu sonuçlar, müşteri kaybı tahmininde kullanılan modellerin seçiminde dikkate alınması gereken önemli faktörleri vurgular. Gelecekteki çalışmalarda, veri setinin genişletilmesi ve farklı özniteliklerin eklenmesi gibi iyileştirmelerle daha kapsamlı analizler yapılabilir.

KAYNAKLAR

- [1] Kunt, M. S. (2019). Telekomünikasyon sektöründe müşteri kaybı analizi (Master's thesis, Fen Bilimleri Enstitüsü)
- [2] Ataseven, B. (2013). Yapay sinir ağları ile öngörü Customer Segmentation and Customer Profiling for a Mobile Telecommunications Company Based on Usage Behavior, S.M.H Jansen, July 17, 2007.
- [3] Ravisankar, Pediredla, et al. "Detection of financial statement fraud and feature selection using data mining techniques." *Decision Support Systems* 50.2 (2011): 491-500.
- [4] Privacy Preserving Data Mining in Telecommunication Services) Granmo, O., and Vladimir A. Oleshchuk. "Privacy preserving data mining in telecommunication services." *Teletronikk* 103.2 (2007): 84
- [5] Lin, Qining. "Mobile customer clustering analysis based on call detail records." *Communications of the IIMA* 7.4 (2007): 95- 100.
- [6] Namli, E., & Murat, S. (2019). Müşteri Odaklı Pazarlama Stratejileri için Veri Madenciliği Teknikleri Kapsamında Perakende Sektöründe Kümeleme Analizi Uygulaması. *Gümüşhane Üniversitesi Sosyal Bilimler Dergisi*, 10, 317-327.
- [7] Kitts, B., Melli, G., & Rexer, K. (2005). Data Mining Case Studies. In *The First International Workshop on Data Mining Case Studies, 2005 IEEE International Conference on Data Mining, Huston, USA*.
- [8] Özmen, M., Delice, Y., & Kızılkaya Aydoğan, E. (2018). Telekomünikasyon Sektöründe PSO ile Müşteri Bölümlemesi.
- [9] Gündoğdu, E. (2023). Veri madenciliği çerçevesinde yapay sinir ağları ve birliktelik kuralı analizi üzerine borsa İstanbul 30 endeksinde bir uygulama (Doctoral dissertation, Bursa Uludag University (Turkey))
- [10] Wang, Q. Q., Yu, S. C., Qi, X., Hu, Y. H., Zheng, W. J., Shi, J. X., & Yao, H. Y. (2019). Overview of LR model analysis and application. *Zhonghua yu fang yi xue za zhi [Chinese journal of preventive medicine]*, 53(9), 955-960.
- [11] Wang, T., & Li, W. H. (2010, December). Naive Bayes software defect prediction model. In *2010 International conference on computational intelligence and software engineering* (pp. 1-4). Ieee.
- [12] Vesanen, Jari, and Mika Raulas. "Building bridges for personalization: a process model for marketing." *Journal of Interactive Marketing* 20.1 (2006): 5-20.
- [13] Groth, Robert. *Data Mining: A hands on approach*. Prentice Hall, 1998.
- [14] Kuzey, C. (2012). Veri madenciliğinde destek vektör makinaları ve karar ağaçları yöntemlerini kullanarak bilgi çalışanlarının kurum performansı üzerine etkisinin ölçülmesi ve bir uygulama. Yayımlanmamış Doktora Tezi, İstanbul Üniversitesi Sosyal Bilimler Enstitüsü, İstanbul.
- [15] Demirhan, T. (2015). Makine öğrenmesi algoritmalarının karmaşıklık ve doygunluk analizinin bir veri kümesi üzerinde gerçekleştirilmesi.
- [16] Şenol, E. M. İ. R., & TİMOR, M. (2013). Yapay sinir ağları ve destek vektör makineleri yöntemlerinin sınıflandırma performanslarının karşılaştırılması: borsa endeks yönünün tahmini üzerine bir uygulama.



Kolera Hastaları için Yapay Zeka Tabanlı Tahmin Modeli

M. Hanefi CALP

Yönetim Bilişim Sistemleri / İktisadi ve İdari Bilimler Fakültesi, Ankara Hacı Bayram Veli Üniversitesi, Türkiye

hanefi.calp@hbv.edu.tr

Özet – Kolera, erken teşhisi ve tedavisi yapılmadığı takdirde ölümcül sonuçlara sebep olabilen oldukça tehlikeli bir hastalıktır. Genel olarak içme suyu, deniz ürünleri ve yiyeceklerden vücuda bulaşmaktadır. Dolayısıyla bu kadar önemli ve tehlikeli bir hastalık olması ve geleneksel yöntemlerle teşhisinin de zor olması çalışmanın motivasyonu ve önemi ortaya çıkmaktadır. Bu çalışmada, yapay zeka yöntemleri kullanılarak Kolera hastalarının tespiti amaçlanmıştır. Çalışmanın yöntemi içerisinde teknik olarak olasılık hesabına göre işlem yapan Naive Bayes, bir veriyi diğer verilerle olan yakınlık ilişkisine göre sınıflandıran K-En Yakın Komşu, veri setini mümkün olduğunca küçük parçalara bölmek suretiyle geliştiren Karar Ağacı ve son olarak insan beyninin çalışma prensibine dayanarak geliştirilmiş bir teknolojisi olan Yapay Sinir Ağları algoritmaları kullanılmıştır. Veri seti, Kaggle web sitesinden elde edilmiş olup her bir teknik kullanılarak modeller oluşturulmuştur. Oluşturulan modeller analiz edildiğinde, en yüksek performansın %99'luk bir başarı oranıyla YSA algoritması kullanılarak elde edildiği görülmüştür. Çalışmanın sonraki çalışmalara ışık tutması beklenmektedir.

Anahtar Kelimeler – Kolera, Salgın, Yapay Zeka, Tahmin, Teşhis

I. GİRİŞ

Bulaşıcı hastalıklar, mikroorganizma olarak tanımlanan oldukça küçük canlıların sebep olduğu bir hastalıktır. Kolera da bunlardan bir tanesidir. Kolera, içme suyu, deniz ürünleri ve yiyeceklerle “Vibrio Cholerae” olarak isimlendirilen bir bakterinin bulaşması sonucunda gerçekleşen bir hastalıktır. Kolera, tedavi edilmezse tehlikeli ve ölümcül sonuçlara sebep olabilecek bir hastalıktır. Burada hijyen çok önemli olup temizlik yetersiz düzeyde ise kolera için iyi bir zemin olur [1]. Bu hastalığın tedavi sürecinde öncelikle yapılması gereken kaybedilen sıvı ve elektrolitlerin tekrar kazanılmasıdır. Bu aşamada yapılan bir tedavi ise kolera hastasının damar yolu ile sıvı verilmesidir. Bu noktada doğru ve zamanında yapılan teşhis ve tedavinin önemi oldukça büyüktür [2,3].

Bu bağlamda çalışmada, Kolera hastaları için yapay zeka tabanlı bir teşhis modeli önerilmiştir. Çalışmanın tüm bölümleri şöyle şekillenmiştir: Öncelikle literatür taraması, daha sonra çalışmanın yöntem ve teknik kısmı, sonrasında elde edilen bulgular ve yapılan yorumlar ve son olarak da çalışmanın sonuç ve öneriler bölümü verilmiştir.

II. LİTERATÜR

Bu bölümde, kolera hastalığı ile ilgili çalışmaların kısa bir özetine yer verilmiştir. Bu çalışmalar, sistematik olarak analiz edilmiştir. Bulaşıcı hastalıklar, insan hayatını çok fazla tehlikeye atan önemli bir sağlık problemleri olagelmıştır. Özellikle de savaş ve göçler bu hastalıkların hızla yayılmasında etkili olmuş ve çok büyük sayılarda can kayıplara meydana gelmiştir. Kolera, tehlikeli ve ölümcül olması özellikleriyle bunlardan biridir [4,5]. Kolera gibi hastalıklar, genel olarak bulaşıcı oldukları için salgın hastalıklar olarak nitelendirilmişlerdir. Salgınların nedeni ise, mikroorganizmaların sel, savaş, nüfus fazlalığı/artışı, depresyon, kıtlık, iklim değişiklikleri ve çevre kirliliği gibi doğa olaylarına verdikleri tepkilerdir [6]. Kolera salgınları, temiz olmayan içme suyu, insan dışkıları ve kanalizasyonunun artılmamasının bir sonucudur [7]. Kolera hastalığı için alınan birtakım tedbirlerin yanısıra hastalığın tespiti ve ilanı için de bir sistem geliştirilmiştir. Söz konusu hastalığın bulaşmaması için bazı tedbirler

alınmaktadır [8]. Türkiye de bu konuda tedbirler almış özellikle yurt dışında gelmemesi için sınırlara kontrol birimleri ve laboratuvarlar kurmuştur. Alınan bu tedbirler sayesinde, salgın, kontrol altına alınabilmektedir [9]. Salgın hastalıklardan, genel olarak insanlık çok fazla etkilenmiştir. Çünkü bu hastalıklar yüzünden, binlerce insan ölmüştür [10]. Dünya Sağlık Örgütü (DSÖ) sağlığa ilişkin standartların belirlenmesi noktasında sadece bir araç olarak tavsiyede bulunmamış, aynı zamanda ihtiyaç halinde hukuki temeli olan sözleşmeleri, anlaşmaları veya tüzüklere de onay verebilmektedir [11].

III. MATERYAL VE YÖNTEM

Bu çalışmada, Kolera hastalığının tespiti için yapay zeka algoritmalarından olan Naive Bayes, KNN, Karar Ağacı ve Yapay Sinir Ağları ile modeller oluşturularak tahmin ve teşhis süreci gerçekleştirilmiştir. Bu noktada Bayes teoremi, olasılık dağılımı içinde koşullu olasılıklar ile marjinal olasılıklar arasındaki ilişkiyi bir rassal değişken için gösterir [12]. KNN, tahmin edilecek bağımsız değişkenlerin oluşturduğu vektörün en yakın komşularının hangi sınıfa ait olduğu veya daha doğru bir ifadeyle yoğun olduğu ölçütü üzerinden sınıfını belirler [13]. Karar ağacı, belirli ölçüt veya koşullar dikkate alınarak bir kararın muhtemel çözümlerinin grafik (ağaç) olarak gösterilmesidir [14]. Yapay sinir ağları (YSA) ise, insan beyninin öğrenme fonksiyonu ile yeni bilgiler üretebilme ve oluşturabilme gibi yeteneklere sahip olan ve bunları otomatik olarak gerçekleştirebilen bilgisayar sistemleridir [15].

A. Çalışmanın Amacı

Bu çalışmada, tehlikeli bir salgın hastalık olan Kolera hastalığının yapay zeka yöntemleri kullanılarak teşhisi amaçlanmıştır. Böylece, erken teşhisin sağlanması ve salgın hastalıklara karşı nasıl tedbirler alınması gerektiği de ortaya konulmuştur.

B. Veriseti

Uygulama aşamasında öncelikle Kaggle web sitesinden Kolera hastalığı ile ilgili veri seti alınmıştır. Bu veri setinin içerisinde Dünya Bölgeleri ve bu ülkelerdeki kolerayla ilgili ölüm oranları verilmiştir. Veriseti içinde, *Country*, *year*, *Number_of_reported_cases_of_cholera*, *Number_of_reported_deaths_from_cholera*, *Cholera_case_fatality_rate*, *WHO_Region* alanları bulunmaktadır.

C. Modellerin Oluşturulması, Bulgular ve Tartışma

Naive Bayes Algoritması

Naive Bayes sınıflandırma algoritmasını öncelikle Gaussian modeli ile kullanılmıştır. Scikit-learn kütüphanesinden temin edilen bu modelin doğruluğu %75 olarak bulunulmuştur. Ayrıca test setindeki 69 noktanın 17'sinin yanlış sınıflandırıldığı tespit edilmiştir. Bu sonucu iyileştirmek için veri setindeki özelliklerin dağılımları incelenmiştir. Bunun için histogram grafiği kullanılmıştır. Bu histogram grafiği veri setindeki noktaların Gaussian modeline değil Bernoulli modelinin dağılımına daha yakın olduğunu göstermiştir. O yüzden algoritmada, Bernoulli modeli ile kullanılmasına karar verilmiştir. Sonrasında %89 doğruluk elde edilmiş ve yalnızca 69 noktanın 7'si yanlış sınıflandırılmıştır. Böylelikle doğruluk veri setine daha uygun olan bir model kullanılarak iyileştirilmiştir.

```
from sklearn.naive_bayes import GaussianNB
nb=GaussianNB()
nb.fit(x_train,y_train)
GaussianNB(priors=None, var_smoothing=1e-09)
```

```
print(nb.score(x_test,y_test))
0.7536231884057971
```

```
y_pred = nb.fit(x_train, y_train).predict(x_test)
print("Number of mislabeled points out of a total %d points : %d" % (x_test.shape[0], (y_test != y_pred).sum()))
Number of mislabeled points out of a total 69 points : 17
```

```
X_frame = pd.DataFrame(x)
X_frame.hist()
```

```
array([[<matplotlib.axes._subplots.AxesSubplot object at 0x0000023881F90488>,
<matplotlib.axes._subplots.AxesSubplot object at 0x00000238823514C8>],
[<matplotlib.axes._subplots.AxesSubplot object at 0x0000023882383F48>,
<matplotlib.axes._subplots.AxesSubplot object at 0x0000023882389AC8>]],
dtype=object)
```

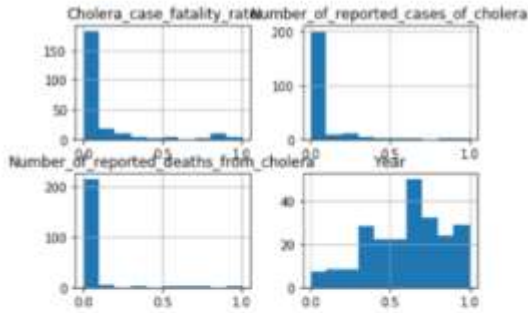

```
from sklearn.naive_bayes import BernoulliNB
clf = BernoulliNB()
clf.fit(x_train, y_train)
print(clf.score(x_test,y_test))
0.8985507246376812
```

```
y_pred2 = clf.fit(x_train, y_train).predict(x_test)
print("Number of mislabeled points out of a total %d points : %d" % (x_test.shape[0], (y_test != y_pred2).sum()))
Number of mislabeled points out of a total 69 points : 7
```

Şekil 1. Naive Bayes Kod Bloğu ve Modelin Doğruluk Grafiği

KNN Algoritması

Bu algoritma için Scikit learn kütüphanesinden KNN modeli kullanılmıştır. Bu modelin uygulanması için öncelikle komşu nokta sayısı belirlenmiştir. Bunun için 15 komşu noktaya kadar değişik komşu sayıları için test ve eğitim veri setlerinin doğrulukları araştırılmıştır. Bütün doğruluk değerleri Şekil 2'deki grafikte gösterilmiştir. Komşuluk noktaların sayısı arttıkça eğitim seti için doğruluk değerinin azaldığı gözlemlenmektedir. Yani bu durumda eksik öğrenme sözü konusu olmaktadır. O yüzden modelin en iyi uyum sağladığı durum test ve eğitim setinin doğruluğunun yüksek ve birbirlerine yakın olduğu noktadır. Bu değer ise komşuluk sayısının 3 olmasıyla elde edilmiştir. Komşuluk sayısı 3'e eşit iken model %94 doğruluk değeri vermektedir.

```
score_listesi_test=[]
score_listesi_train=[]

for each in range(1,15):
    knn2=KNeighborsClassifier(n_neighbors=each)
    knn2.fit(x_train,y_train)
    score_listesi_test.append(knn2.score(x_test,y_test))
    score_listesi_train.append(knn2.score(x_train,y_train))
```

```
plt.plot(score_listesi_test,label='test')
plt.plot(score_listesi_train,label='train')
plt.title("Olabilecek En Yüksek Score (nn:1-15 için) {}".format(np.max(score_listesi_test)))
plt.xlabel("n-neighbor degeri")
plt.ylabel("Score")
plt.legend()
plt.show()
```

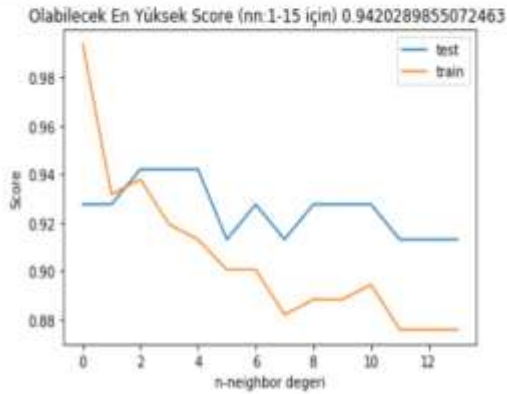

Şekil 2. KNN Kod Bloğu ve Modelin Doğruluk Grafiği

Karar Ağacı

Karar ağacı algoritmasında kolera hastalarının sayısı ve kolera hastalığından ölenlerin sayısı özellikleri kullanılmıştır. Bu özellikler için ölümlerin ve yeni vakaların Avrupa kıtasına dağılımına göre sınıflandırması yapılmıştır. Veri seti algoritma uygulanmadan önce normalleştirilmiştir. Oluşturulan karar ağacının derinlik değeri 13 olarak elde edilmiş olup bu algoritma için Gini kriteri kullanılmıştır. Kök hücre için yeni kolera vakalarının 0.001'den küçük olması baz alınmıştır. Yapraklara bakıldığı zaman ise bütün Gini değerlerinin sıfır olduğu görülmektedir. Bu durum sınıflandırmanın doğru yapıldığını göstermekte ancak doğruluk değeri %72 olarak bulunulmuştur.

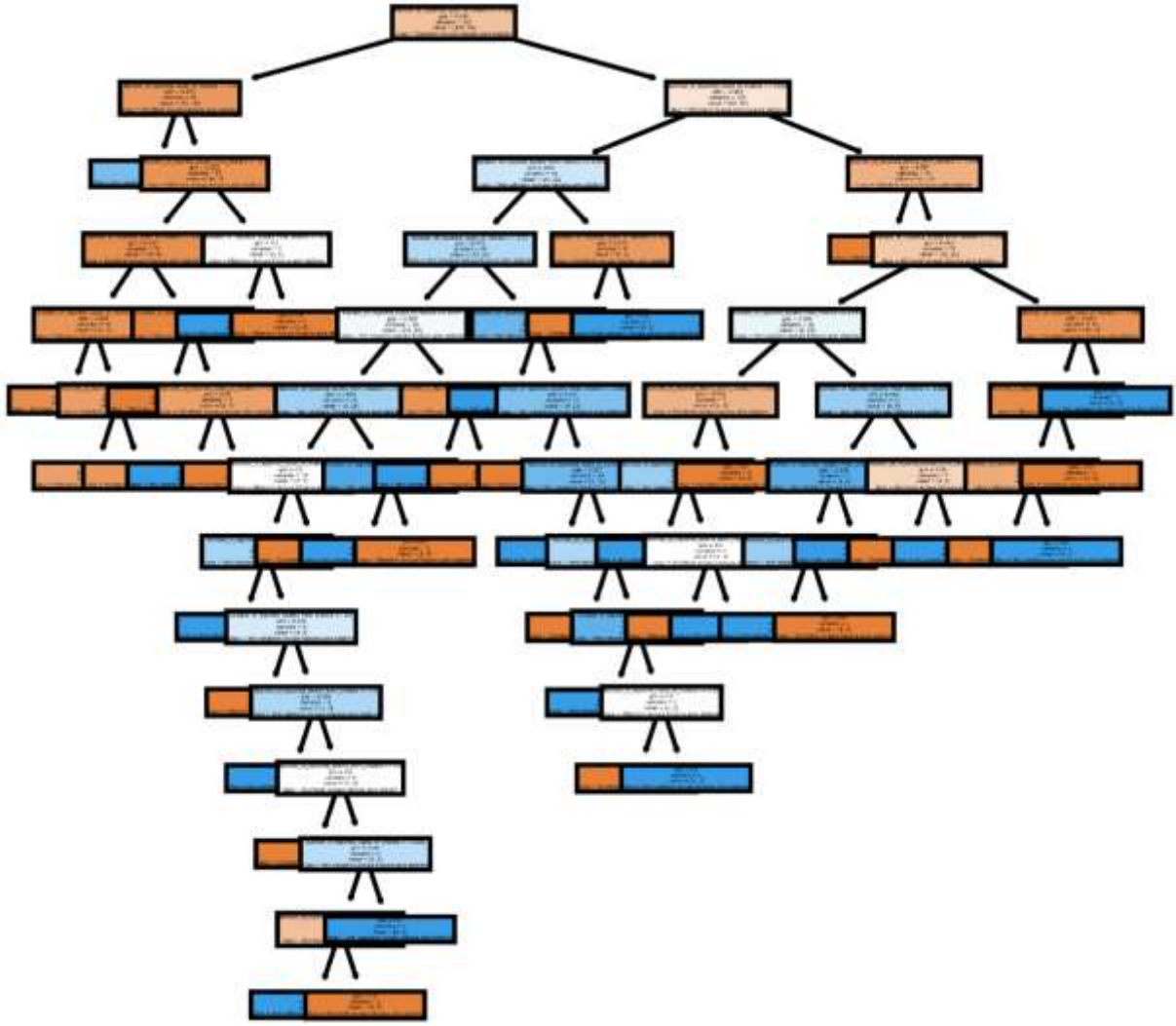

Şekil 3. Karar Ağacı Grafiği

Yapay Sinir Ağları

Bu yöntem uygulanarak elde edilen modelin doğruluk oranı %99 olarak bulunmuştur. Sonuç grafiği Y_1 Ölüm, Y_2 Vaka olmak üzere 2 girdiden; Z_1 Oranı, Z_2 Bölge olmak üzere 2 çıktıdan oluşmaktadır. 230 tane sinir hücresi mevcuttur. Y'ler tüm hücrelere bağlanmaktadır. Sinir hücreleri ise Z'lere yani çıktılara bağlanmaktadır. B_11 Intercepts temsil etmektedir. 0.11 değerindedir. W_11 birinci girdinin birinci seviyedeki ağırlığıdır. -0.1 değerindedir. W_12 birinci girdinin ikinci seviyedeki ağırlığıdır. 0.89 değerindedir. B_21 Intercepts temsil etmektedir. 0.07 değerindedir. Ağırlıklar ile B katsayıları toplandığı zaman y değerleri ortaya çıkmaktadır.

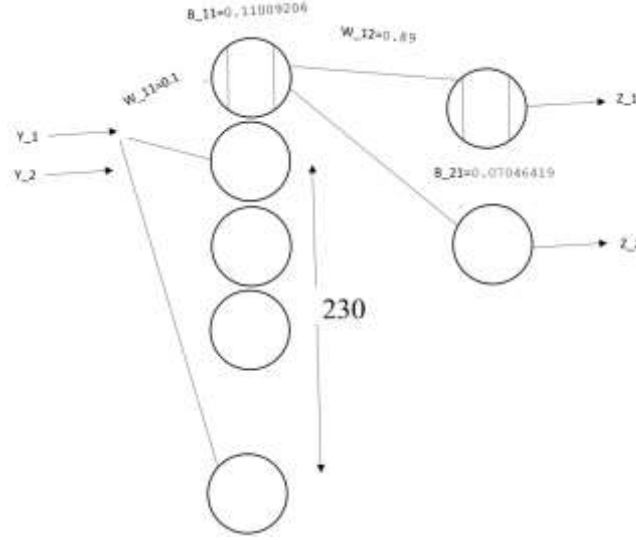

Şekil 4. YSA Modeli

Çizelge 1’de, tüm sonuçların karşılaştırılmasına yer verilmiştir. Çizelge incelendiğinde en yüksek performansa veya en yüksek doğruluk oranına sahip modelin YSA olduğu açıkça görülmektedir.

Çizelge 1. Modellerin Performanslarının Karşılaştırılması

Model No	Model Adı	Doğruluk Yüzdesi (%)
1	Naive Bayes	75
2	KNN	94
3	Karar Ağacı	72
4	YSA	99

IV. SONUÇLAR VE ÖNERİLER

Bu çalışmada, küresel salgın olan Kolera hastalığının yapay zeka yöntemleri ile tahmini gerçekleştirilmiştir. Bu çerçevede, dünyadaki bölgeler ve bu bölgelerde bıraktığı izler ortaya konmuştur. Kolera, tedavi edilmediği takdirde ölümcül olabilen tehlikeli hastalıkların başında yer almaktadır. Çıkarılan sonuçlar da kolera hastalığının çok ölümcül olduğu ve ciddi tahribatlara yol açtığı gözlemlenmiştir. Bu çalışmada kullanılan yöntemler Naive Bayes, KNN, Karar Ağacı ve Yapay Sinir Ağları’dır. Bu yöntemler dikkate alındığında, KNN yöntemi ile %94 doğruluk oranı, Naive Bayes yöntemi ile %89 doğruluk oranı, Karar Ağacında %72 doğruluk oranı ve Yapay Sinir Ağlarının doğruluk oranı %99 sonuçları çıkmıştır. Bu doğruluk oranlarına dayanarak, karar ağacı dışında oldukça verimli sonuçlar elde edilmiştir. Bu sonuçlar doğrultusunda kolera etkinliği en çok gelişmemiş ülkelerde olduğu görülmüştür. Gelişmiş ülkeler ise çok daha az kayıplarla bu süreci atlattır. Kolera virüsünün net bir tedavisi olmadığı için tedavi yöntemi olarak kaybedilen sıvı ve tuzların yerine konması ve antibiyotik ile yapılmaktadır. Bu da geleneksel yöntemlere girmekte ve yeterince etkili sonuçlar alınamamaktadır. Bu noktada yapay zeka yöntemleri kullanılarak çok daha etkin bir teşhis ve tedavi süreci işletilebilmektedir.

KAYNAKLAR

- [1] Erdal SAĞLAM, Kolera nedir. “<https://www.hurriyet.com.tr/kelebek/saglik/kolera-nedir-kolera-salgini-ne-zaman-ortaya-cikmisti-41476784>, Erişim Tarihi: 24.01.2024.
- [2] Hakan Karagöl, Kolera nedir? <https://www.medicalpark.com.tr/kolera-nedir/hg-1850> Erişim Tarihi: 23.01.2024.
- [3] Mehmet ÜSTÜNDAĞ, Tarihin En Ölümcül Salgın Hastalıkları. <https://www.trthaber.com/haber/dunya/tarihin-en-olumcul-salgin-hastaliklari-463427.html> Erişim Tarihi: 21.02.2020
- [4] İsmail, Özer. (2020). Türkiye Cumhuriyeti Sınırlarını Tehdit Eden Kolera Saldırıları ve Alınan Savunma Tedbirleri. Ordu Üniversitesi Sosyal Bilimler Enstitüsü Sosyal Bilimler Araştırmaları Dergisi, 10(1), 201-216.
- [5] Demirkol, K. (2018). Adana ve kolera (1890-1895). Dumlupınar Üniversitesi Sosyal Bilimler Dergisi, (56), 141-156.
- [6] Parıldar, H. (2020). Tarihte bulaşıcı hastalık salgınları. Tepecik Eğitim ve Araştırma Hastanesi Dergisi, 30, 19-26.
- [7] Donkor, A. G., & Namaitijiang, M. (2019). The Cholera Outbreak in Ghana. Estüdam Halk Sağlığı Dergisi, 4(3), 371-376.

- [8] Fuat, İnce., & Evcil, F. Y. (2022). Arşiv Belgeleri Işığında Türkiye'nin Salgın Tedbirleri: Kolera Örneği (1924-1973). *SDÜ Tıp Fakültesi Dergisi*, 27(3), 393-401.
- [9] Ertem, B. (2020). İstanbul Sağmalcılar kolera salgını (1970). *Gaziantep University Journal of Social Sciences*, 19(COVID-19 Special Issue), 647-660.
- [10] Menekşe, M. (2020). İzmir'de Kolera Salgını ve Etkileri (1893). *Tarih Araştırmaları Dergisi*, 39(67), 385-433.
- [11] Samancı, U. (2016). Dünya Sağlık Örgütü ve Normatif İşlevi. *Dokuz Eylül University Journal of Graduate School of Social Sciences*, 18(1).
- [12] Bayes Teorimi, Vikipedi. https://tr.wikipedia.org/wiki/Bayes_teoremi, Erişim Tarihi: 10.01.2024.
- [13] Evren Arslan, Makine Öğrenmesi KNN. "<https://medium.com/@arslanv/makine-%C3%B6%C4%9Frenmesi-KNN-k-nearest-neighbors-algoritmas%C4%B1-bdfb688d7c5f>" Erişim Tarihi: 19.01.2024.
- [14] Sezgin, Karar Ağacı Nedir. <https://www.sezginkoyun.com/karar-agaci-nedir/> Erişim Tarihi: 15.02.2024.
- [15] Elif Yıldım, Yapay Sinir Ağı. "<https://www.veribilimiokulu.com/blog/yapay-sinir-agiartificial-neural-network-nedir/>", Erişim Tarihi: 02.02.2024.



Derin Öğrenme Tabanlı Hava Sıcaklığı Tahmini: Mumbai için Bir Vaka Çalışması

Anıl Utku^{1*}

¹Bilgisayar Mühendisliği, Munzur Üniversitesi, Türkiye

*(anilutku@munzur.edu.tr)

Özet – Hava sıcaklık tahminleri, geleneksel olarak uzun süreler boyunca farklı atmosferik koşulları kullanan büyük ve karmaşık fizik modelleri yardımıyla gerçekleştirilmektedir. Ancak modellerde yaşanan istikrarsızlıklar ve yüksek enerji tüketimleri, yapay zekâ tabanlı yöntemlere olan ihtiyacı doğurmuştur. Bu çalışmada, LSTM tabanlı bir hava tahmin modeli geliştirilmiştir. Geliştirilen model LR, RF, SVM, MLP ve RNN gibi popüler makine öğrenmesi ve derin öğrenme modelleriyle karşılaştırılmıştır. Mumbai şehrine ait yaklaşık 4 yıllık, günlük hava sıcaklık verileri kullanılarak yapılan deneysel çalışmalar, LSTM'in 0,610 MAE ve 0,843 R² değeri ile karşılaştırılan modellerden daha başarılı olduğunu göstermiştir.

Anahtar Kelimeler – Hava sıcaklık tahmini, derin öğrenme, makine öğrenmesi, LSTM, RNN

I. GİRİŞ

Sıcaklık, nem ve rüzgâr gibi hava koşulları insanların yaşantısını birçok yönden etkilemektedir. Hava durumu tahmini, afet yönetimi, trafik yönetimi ve ulaşım planlaması gibi konularda analitik destek sağlamaktadır [1]. Ancak geleneksel hava tahmin yöntemleri, gözlem verilerindeki dinamiklerin elde edilmesindeki zorluklar ve güçlü hesaplama kaynaklarının gerekliliği gibi zorluklarla karşı karşıyadır [2]. Bu sebeple hava tahmininde yapay zekâ tabanlı yöntemlerin kullanımı giderek artan bir çalışma alanı haline gelmiştir.

Hava tahmininde yapay zekâ tekniklerinin kullanılması, tahminlerin verimliliğini artırmada önemli bir rol oynamaktadır [3]. Geleneksel hava tahmini yöntemleri karmaşık fiziksel modellere dayanırken, yapay zekâ tabanlı yöntemler geleceğe dönük tahminler elde etmek için geçmiş hava durumu verilerindeki örüntüleri ve ilişkileri belirlemektedir [4]. Yapay zekâ tabanlı modellerin etkinliği, büyük ölçüde uydu görüntüleri ve meteoroloji istasyonlarından elde edilen veriler gibi çeşitli veri kaynakları kullanılarak eğitilebilmesinden kaynaklanmaktadır [5]. Bu veri kaynakları, modellerin tahminlerini gerçek dünyada gözlemlenen hava koşullarıyla karşılaştırarak modellerin doğruluğunu geliştirmek için de kullanılabilir. Eğitilen modeller, farklı hava parametreleri arasındaki ilişkilerin çıkarılarak tahmin doğruluğunun artırılmasını sağlar [6].

Yapay zekâ tabanlı tahmin modelleri, geleneksel modellere kıyasla yeni bilgilerle güncellenmeleri ve gerçek zamanlı analiz yetenekleri sayesinde daha başarılı tahminler üretmektedir [7]. Tahmin doğruluğunun artırılması hükümetler ve yerel yönetimler için kaynak planlaması, afet yönetimi, kamu güvenliği ve iklim değişikliği gibi alanlarla planlamalar yapılmasına ve stratejiler geliştirilmesine olanak tanır [8].

Bu çalışmada, tahmin kalitesi ve doğruluğunu arttırabilmek amacıyla LSTM tabanlı bir tahmin modeli geliştirilmiştir. Geliştirilen modelin etkinliği LR, RF, SVM, MLP ve RNN ile karşılaştırılmıştır. Mumbai şehrine ait yaklaşık 4 yıllık, günlük sıcaklık verileri kullanılarak modeller test edilmiştir. Mean Squared Error (MSE), Root Mean Squared Error (RMSE), Mean Absolute Error (MAE) ve R-Squared (R²) metrikleri kullanılarak yapılan deneysel çalışmalar, LSTM tabanlı tahmin modelinin karşılaştırılan modellerden daha başarılı olduğunu göstermiştir.

II. MATERYAL VE METOT

Bu çalışmada, hava durumu tahminine yönelik LSTM tabanlı bir model geliştirilmiştir. Geliştirilen model LR, RF, SVM, MLP ve RNN gibi popüler modeller ile uygulamalı olarak karşılaştırılmıştır. Uygulanan modellerin etkinliğini test etmek için Hindistan'ın en büyük şehri olan Mumbai'ye ait hava durumu verileri kullanılmıştır [9]. Kullanılan veriseti 01/01/2016 ile 15/11/2020 tarihleri arasındaki günlük hava durumu verilerinden oluşmaktadır. Tablo 1'de örnek olarak kullanılan verisetinin ilk 5 satırı görülmektedir.

Tablo 1. Kullanılan veriseti

Tarih	Sıcaklık
01/01/2016	28.4
02/01/2016	26.8
03/01/2016	25.5
04/01/2016	26.4
05/01/2016	27.1

Şekil 1'de ise zamana göre hava sıcaklıklarının değişimi görülmektedir.

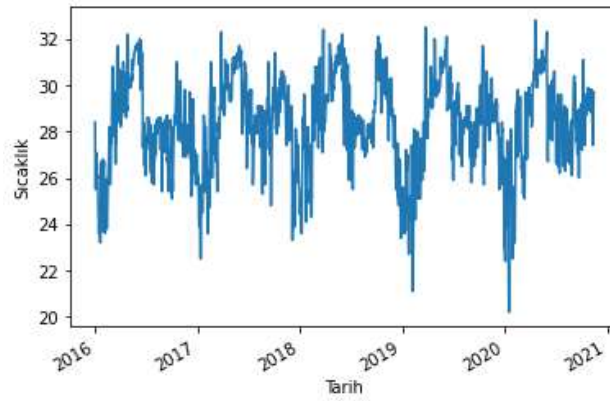

Şekil 1. Zamana göre hava sıcaklıklarının değişimi

Modeller verisetine uygulanmadan önce, verisinde eksik ve hatalı veri kontrolü yapılmıştır. Veriler StandardScaler kullanılarak ölçeklenmiştir. Kullanılan veriseti zaman serisi verilerinden oluştuğu için veriler denetimli öğrenme problemi yapısına dönüştürülmüştür. Bu amaçla kayan pencere yöntemi kullanılmıştır. Kayan pencere yöntemi, verileri sabit boyuttaki pencerelere bölmeyi ve her pencereyi bağımsız olarak işlemeyi ifade etmektedir [10]. Örneğin, boyutu 3 olan bir kayan pencere, ardışık zaman serisi verilerini pencerelere bölmeyi ve her pencereyi bağımsız olarak işlemeyi içermektedir. Bu senaryoda ilk pencere için t_1 , t_2 ve t_3 veri noktaları girdi, t_4 veri noktası ise çıktı olacaktır.

Verisetinin %60'ı eğitim ve %40'ı ise test için ayrılmıştır. Eğitim verilerinin %10'u model hiper-parametrelerinin optimizasyonu için kullanılmıştır. Modellerin en iyi parametrelerle çalışabilmesi için GridSearch kullanılarak hiper-parametre optimizasyonu yapılmıştır. GridSearch, her bir modelin girilen parametre aralıklarındaki tüm değerler için çalıştırılarak en başarılı sonucu veren parametre kombinasyonunun belirlenmesini ifade etmektedir [11].

III. GELİŞTİRİLEN LSTM TABANLI TAHMİN MODELİ

Bu çalışmada, Şekil 2'de görüldüğü gibi tahmin doğruluğunu ve başarısını arttırmak için LSTM tabanlı bir hava sıcaklığı tahmin modeli geliştirilmiştir.

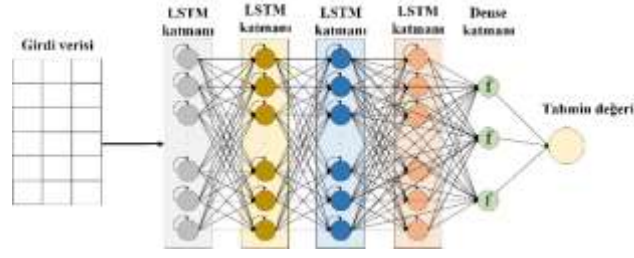

Şekil 2. Geliştirilen LSTM tabanlı tahmin modeli

Geliştirilen model, 4 adet LSTM katmanından oluşmaktadır. Yapılan hiper-parametre optimizasyonu çalışmaları sonucunda LSTM'in parametreleri belirlenmiştir. Her bir LSTM katmanında 64 nöron bulunmaktadır. Optimizer olarak Adam, loss fonksiyonu için MSE kullanılmıştır. Epoch 100 ve batch size 16'dır.

IV. DENEYSEL SONUÇLAR

Karşılaştırılan her bir model için MSE, RMSE, MAE ve R^2 metrikleri kullanılarak deneysel sonuçlar elde edilmiştir. Tablo 2 ve Şekil 3'te her bir model ve değerlendirme metriği için karşılaştırmalı deneysel sonuçlar görülmektedir.

Tablo 2. Karşılaştırmalı deneysel sonuçlar

	LR	RF	SVM	MLP	RNN	LSTM
MSE	0,675	0,661	0,660	0,658	0,653	0,646
RMSE	0,822	0,813	0,812	0,811	0,808	0,804
MAE	0,618	0,616	0,615	0,615	0,613	0,610
R^2	0,836	0,839	0,839	0,840	0,841	0,843

Tablo 2 ve Şekil 3'te görüldüğü deneysel sonuçlar, LSTM'in karşılaştırılan modellerden daha başarılı olduğunu göstermiştir. LSTM'in ardından sırasıyla RNN, MLP, SVM, RF ve LR başarılı olmuştur.

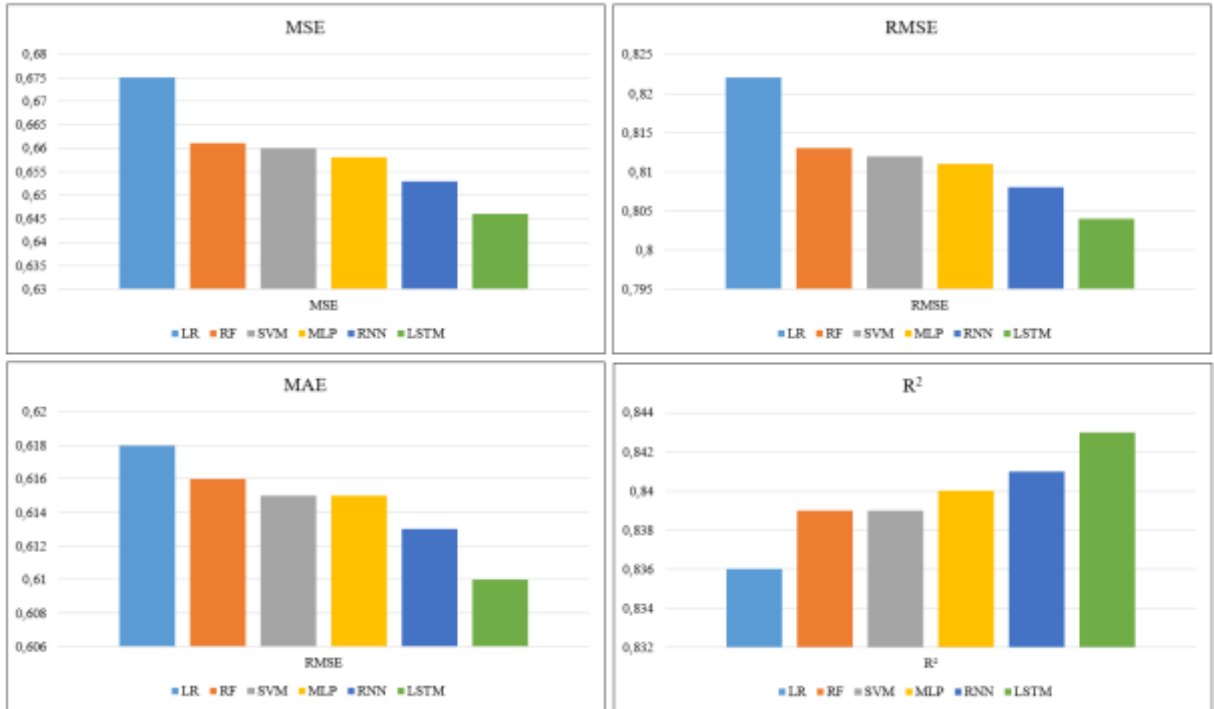

Şekil 3. Karşılaştırmalı deneysel sonuçlar

LSTM'in RNN'den daha başarılı olması, LSTM'in sıralı verileri işleme ve öğrenme yeteneği ile yorumlanabilir. LSTM yapısı gereği uzun vadeli bağımlılıkları öğrenme yeteneğine sahiptir. LSTM, RNN'de oluşabilecek kaybolan gradyan sorununu çözmek için tasarlanmıştır. Kaybolan gradyan sorunu, ağırlık uzun vadeli bağımlılıklardan öğrenmesini ve hatırlamasını zorlaştırmaktadır. Kaybolan gradyan

sorunu, LSTM'e eklenen, hatırlama ve unutmaya olanak sağlayan bellek hücreleri ve geçiş mekanizmaları sayesinde çözümlenmektedir.

LSTM'in MLP'den daha başarılı olması, uzun vadeli bağımlılıkları hatırlama yeteneğinin yanı sıra LSTM'in zaman serisi verilerindeki dinamik yapıya uyum sağlama yeteneği ile yorumlanabilir. Ayrıca LSTM, zaman serisi verilerindeki gürültüye daha dayanıklıdır bu sayede aşırı uyum problemini azaltmaktadır. LSTM'in SVM, RF ve LR'den daha başarılı olması, LSTM'in zaman serisi verilerine özgü olarak tasarlanmış özel yapısı ile yorumlanabilir. LSTM, verideki zamana olan bağımlılıkları koruyarak zaman içindeki ilişkileri ve dinamikleri yakalama kapasitesine sahiptir. Geleneksel makine öğrenmesi yöntemleri ise sahip oldukları sınırlı öğrenme yetenekleri sebebiyle zaman serisi verilerinin dinamik yapılarına yeterince uyum sağlayamaz.

V. SONUÇLAR

Geleneksel hava durumu tahmin modelleri, belirli parametrelere sahip birden fazla alternatif fiziksel şema ile tanımlanan çeşitli fiziksel süreçleri içermektedir. Model konfigürasyonu sırasında fiziksel şemaların seçimi ve karşılık gelen fiziksel parametrelerin seçimi, model tahminlerinin doğruluğunu önemli ölçüde etkileyebilir. Bu nedenle her zaman en başarılı sonuçlara sahip parametre kombinasyonlarının belirlenmesi zordur.

Bu çalışmada, geleneksel tahmin modellerindeki çoklu fiziksel süreçlerin etkileşimi nedeniyle yaşanan belirsizlikleri ortadan kaldırmak, tahmin doğruluğunu ve başarısını arttırmak amacıyla LSTM tabanlı bir tahmin modeli geliştirilmiştir. Geliştirilen model LR, RF, SVM, MLP ve RNN gibi popüler makine öğrenmesi ve derin öğrenme modelleriyle karşılaştırılmıştır. Mumbai'ye ait yaklaşık 4 yıllık hava sıcaklık verilerini içeren bir veriseti üzerinde MSE, RMSE, MAE ve R2 metrikleri kullanılarak deneysel çalışmalar yürütülmüştür. Deneysel sonuçlar, LSTM'in karşılaştırılan modellerden daha başarılı bir tahmin performansına sahip olduğunu göstermiştir. LSTM'in ardından RNN, MLP, SVM, RF ve LR sırasıyla başarılı olmuştur.

KAYNAKLAR

- [1] D. Huang, S. Wang and Z. Liu, "A systematic review of prediction methods for emergency management," *International Journal of Disaster Risk Reduction*, vol. 62, 102412, 2021.
- [2] X. Ren, X. Li, K. Ren, J. Song, Z. Xu, K. Deng and X. Wang, "Deep learning-based weather prediction: a survey," *Big Data Research*, vol. 23, 100178, 2021.
- [3] W. J. Niu and Z. K. Feng, "Evaluating the performances of several artificial intelligence methods in forecasting daily streamflow time series for sustainable water resources management," *Sustainable Cities and Society*, vol. 64, 102562, 2021.
- [4] M. Waqas, U. W. Humphries, A. Wangwongchai, P. Dechpichai and S. Ahmad, "Potential of Artificial Intelligence-Based Techniques for Rainfall Forecasting in Thailand: A Comprehensive Review," *Water*, vol. 15, no. 16, 2979, 2023.
- [5] B. T. Pham, L. M. Le, T. T. Le, K. T. T. Bui, V. M. Le, H. B. Ly and I. Prakash, "Development of advanced artificial intelligence models for daily rainfall prediction," *Atmospheric Research*, vol. 237, 104845, 2020.
- [6] A. Essien, I. Petrounias, P. Sampaio and S. Sampaio, "A deep-learning model for urban traffic flow prediction with traffic events mined from twitter," *World Wide Web*, vol. 24, no. 4, pp. 1345-1368, 2021.
- [7] M. H. Lipu, M. S. Miah, M. A. Hannan, A. Hussain, M. R. Sarker, A. Ayob and M. S. Mahmud, "Artificial intelligence based hybrid forecasting approaches for wind power generation: Progress, challenges and prospects," *IEEE Access*, vol. 9, pp. 102460-102489, 2021.
- [8] B. Merz, C. Kuhlicke, M. Kunz, M. Pittore, A. Babeyko, D. N. Bresch and A. Wurpts, "Impact forecasting to support emergency management of natural hazards," *Reviews of Geophysics*, vol. 58, no. 4, 2020.
- [9] V. Amin. (2023) Mumbai dataset on Kaggle. [Online]. Available: <https://www.kaggle.com/datasets/vikramamin/arima-time-series-mumbai-temperature/data>
- [10] C. Ma, W. Li, J. Cao, J. Du, Q. Li and R. Gravina, "Adaptive sliding window based activity recognition for assisted livings. *Information Fusion*, vol. 53, pp. 55-65, 2020.
- [11] Z. Qu, J. Xu, Z. Wang, R. Chi and H. Liu, "Prediction of electricity generation from a combined cycle power plant based on a stacking ensemble and its hyperparameter optimization with a grid-search method," *Energy*, vol. 227, 2021.



Predicting Customer Satisfaction with Hybrid Basic Filter-Based Feature Selection Method

Tohid Yousefi*, Özlem Varlıklar Aktaş²

¹Computer Engineering Department, Engineering Faculty, Dokuz Eylül University, Turkey

²Computer Engineering Department, Engineering Faculty, Dokuz Eylül University, Turkey

*(tohid.yousefi@hotmail.com) Email of the corresponding author

Abstract – Feature selection methods are crucial in the fields of machine learning and data mining. These methods aim to identify and remove irrelevant, redundant, or low-variance features, thereby improving model performance and reducing computational costs. Basic filtering methods such as constant, quasi-constant, and duplicated feature techniques are employed for this purpose. These methods help clean and refine the feature space, enhancing the model's generalization ability. Additionally, performing feature selection using a hybrid combination of constant, quasi-constant, and duplicated feature methods can further enhance model performance both in terms of time and cost efficiency. This hybrid approach effectively identifies low-variance and redundant features, reducing training time and offering a faster and more economical solution. In conclusion, employing such a hybrid method can lead to more efficient model operation, reducing both time and computational costs while improving performance.

Keywords – Feature Selection, Constant Features, Quasi-Constant Features, Duplicated Features, Basic Filter Methods

I. INTRODUCTION

As data volumes continue to surge across diverse fields such as bioinformatics and machine learning applications like text mining and computer vision, the need for effective data management and analysis strategies becomes increasingly paramount [1]. The rapid expansion of data dimensions, propelled by advancements in technology, underscores the importance of developing robust methodologies to extract meaningful insights from these complex datasets [2]. Data preprocessing stands out as a critical precursor to analysis, ensuring the accuracy and reliability of the data before delving into further investigation. However, as datasets grow in both size and complexity, maintaining data quality presents a significant challenge. In response, techniques for dimensional reduction, such as feature selection, have emerged as invaluable tools to streamline data processing and analysis workflows. By identifying and prioritizing relevant features within large and intricate datasets, feature selection facilitates more efficient and insightful data exploration, even amidst the ongoing deluge of data [3].

Feature selection plays a crucial role in data analysis and machine learning tasks by enabling the identification and prioritization of relevant features within datasets, thereby enhancing model performance, interpretability, and computational efficiency. However, the absence of robust feature selection methods can lead to several challenges, including increased computational complexity, overfitting, and decreased generalization performance of models [4]. To address these issues, basic filtering methods such as constant, quasi-constant, and duplicated feature techniques are commonly employed. Constant feature selection identifies features with constant values across instances, quasi-constant feature selection identifies features with almost constant values, and duplicated feature selection identifies highly similar or duplicate features within the dataset. These methods help streamline the feature space, mitigate overfitting, and improve the

efficiency of subsequent modeling tasks by eliminating redundant or low-variance features. Thus, the effective application of feature selection methods is essential for navigating the complexities of high-dimensional data and maximizing the utility of machine learning models in real-world applications [5].

As mentioned above, for feature selection methods, we thoroughly investigated the constant, quasi-constant, and duplicate feature techniques individually, applying each to our dataset for modeling purposes. Subsequently, we amalgamated these three methods and utilized the random forest machine learning algorithm for prediction. Through this comprehensive approach, we achieved superior results with fewer features, reduced time, and lower costs.

II. MATERIALS AND METHOD

A. Feature Selection

Feature selection is a crucial process in machine learning and data analysis, involving the identification and selection of the most relevant and informative features from a given dataset while discarding irrelevant or redundant ones. As depicted in Figure 1, By reducing the dimensionality of the dataset and focusing on the most significant features, feature selection aims to improve the performance, accuracy, and efficiency of machine learning models [6]. This process helps in mitigating overfitting, reducing computational complexity, enhancing model interpretability, and facilitating better generalization to unseen data. Through careful selection of features, feature selection techniques enable practitioners to streamline the modelling process, optimize predictive performance, and gain deeper insights into the underlying patterns within the data [7].



Fig. 1 Feature selection process

Some common approaches used in feature selection methods include wrapper [8], filter [9], embedded [10], ensemble [11], and hybrid methods [12]. These strategies offer various techniques to assess the importance of features and enhance model performance. However, before applying these methods, it is essential to use basic filter-based methods to clean the dataset and identify irrelevant features. Constant feature, quasi-constant, and duplicated feature methods are commonly used for this purpose, aiming to identify and remove low-information or redundant features [13]. These basic filtering techniques help create a cleaner and more meaningful feature space, facilitating a more effective feature selection process and improving the model's generalization ability. Therefore, basic filter-based methods are considered a crucial initial step in the feature selection process, providing a foundational framework for the implementation of more comprehensive feature selection techniques.

B. Basic Filter Methods

Feature selection is a critical aspect of machine learning and data analysis, ensuring that only the most relevant features are utilized for predictive modelling tasks. Basic filter-based methods serve as the initial step in this process, allowing for the identification and removal of irrelevant or redundant features from the dataset. As depicted in Figure 2, Three commonly used basic filter-based methods include constant feature identification, quasi-constant feature detection, and duplicated feature removal [5].

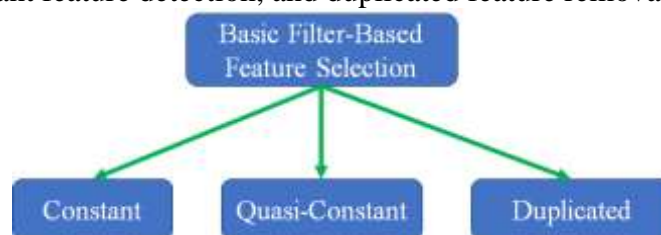

Fig. 2 Basic filter-based feature selection methods

1) *Constant Feature Identification*

This method targets features with a constant value across all instances in the dataset. Such features provide little to no information for predictive modelling tasks and can be safely removed from consideration. Constant feature identification allows for the efficient reduction of dimensionality in the dataset, streamlining subsequent analysis and model building processes.

2) *Quasi-Constant Feature Detection*

Quasi-constant features exhibit minimal variation across instances, making them less informative for predictive modelling. While these features may not be entirely constant, their low variance makes them less useful for distinguishing between different classes or outcomes. Quasi-constant feature detection aims to identify and flag such features for potential removal, thereby improving the overall quality of the feature space.

3) *Duplicated Feature Removal*

Duplicated features refer to those that are highly similar or identical to one another. These redundant features add unnecessary complexity to the dataset and may introduce bias or overfitting in machine learning models. Duplicated feature removal identifies and removes these redundant features, simplifying the feature space and enhancing the robustness of subsequent analyses.

In summary, basic filter-based methods play a crucial role in feature selection by identifying and eliminating irrelevant or redundant features from the dataset. By implementing constant feature identification, quasi-constant feature detection, and duplicated feature removal, practitioners can ensure a cleaner and more informative feature space, leading to improved model performance and interpretability.

C. *Random Forest*

Random Forest [14, 15] is a machine learning algorithm based on multiple decision trees [16]. This algorithm operates with the logic of a forest composed of trees. Each tree is trained with randomly selected features and data samples. Then, each tree makes its own prediction, and the overall prediction is made by taking the most frequent class or the average prediction. This method reduces the tendency of a single tree to have high variance, while combining multiple trees to achieve more stable and accurate predictions. Random Forest has a wide range of applications and delivers effective results in both classification and regression problems. It also offers advantages such as resilience to noise in the dataset and resistance to overfitting, making it a popular choice in various domains [17].

D. *Hybrid Basic Filter Based Methods*

Feature selection methods such as constant, quasi-constant, and duplicated feature techniques are vital in machine learning and data analysis for identifying and eliminating irrelevant or redundant features. Constant feature identification targets unchanging values, quasi-constant feature detection focuses on minimal variation, and duplicated feature removal eliminates redundant features. However, their hybrid usage offers significant advantages. By combining these methods, practitioners can achieve a more comprehensive feature selection process, leading to a cleaner and more informative dataset. This hybrid approach enhances the robustness of feature selection, increases the likelihood of identifying subtle patterns, and allows for greater flexibility in tailoring the process to specific dataset characteristics.

In the hybrid method illustrated in Figure 3, following data preparation, initial basic filter-based methods are employed to filter out constant, quasi-constant, and duplicated features. Subsequently, the data is split into test and training sets; the training set is utilized to construct a predictive model. This model learns relationships within the data and can make predictions on future data. Lastly, the performance of the model is assessed using an evaluation model, and the results are presented to the user. Through the implementation of these steps, the model is ensured to exhibit high performance using filter-based methods with minimal features and cost.

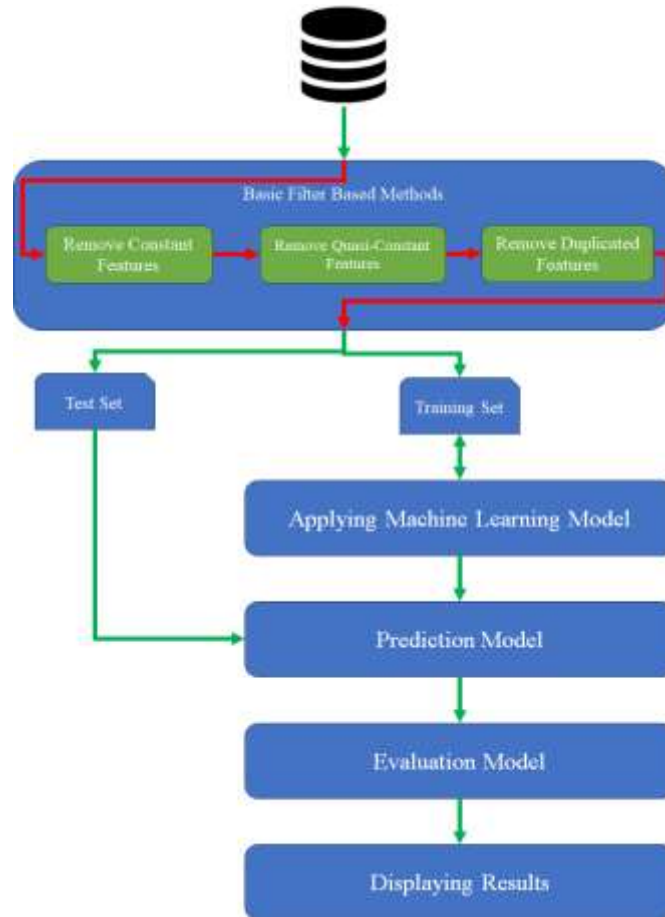

Fig. 3 Flowchart of the hybrid basic filter-based method

E. Dataset

The dataset available via the provided link offers insights into the satisfaction levels of Santander Bank customers. It serves as a valuable resource for understanding customer experiences and preferences within the banking sector. Access the dataset for free on Kaggle: (<https://www.kaggle.com/competitions/santander-customer-satisfaction/data>).

III. RESULTS

Initially, we will explore a straightforward approach where predictions are made directly from the raw data without employing sophisticated filtering techniques. Subsequently, in the second method, we will enhance data quality by applying basic filtering methods before constructing the prediction model. Finally, in the third method, we will combine data preprocessing with model tuning, leveraging the hybrid basic filter-based method to refine both the dataset and the model simultaneously. The adoption of these hybrid techniques not only improves the accuracy and reliability of predictions but also ensures the model's adaptability to the overall dataset. Moreover, model tuning plays a pivotal role in optimizing parameters to maximize the model's performance, thereby enhancing the quality of predictions. Through these comprehensive methodologies, we aim to develop robust prediction models capable of delivering superior results across various domains and applications.

The coding utilized in this study is freely accessible on both Kaggle and Github platforms. Interested readers can access the code repository on Github at the following link: (<https://github.com/tohidyousefi/Predicting-Customer-Satisfaction-with-Hybrid-Basic-Filter-Based-Feature-Selection>). Additionally, the code is also available on Kaggle at the following link (<https://www.kaggle.com/code/tohidyousefi/using-hybrid-basic-filter-based-feature-selection>).

A. Creating a Random Forest Model Without Using the Hybrid Basic Filter-Based Method

In our approach, we developed a model without employing hybrid basic filter-based methods, opting instead to conduct predictions using the Random Forest algorithm without any feature selection. As depicted in Table 1 and Figure 4, metrics were obtained utilizing all features available (369 features). However, it's worth noting that utilizing all features can result in significant time and cost expenditures, particularly in the context of large datasets. This comprehensive approach may lead to excessive computational resources and processing time, which could pose challenges in real-world applications, emphasizing the importance of efficient feature selection techniques to streamline model development and mitigate resource constraints.

Table 1. Metrics of random forest model without using the hybrid basic filter-based method

Number of Features Used: All Features (369)	
Accuracy Train	0.996
Accuracy Test	0.954
R²	0.983
R² Train	0.996
R² Test	0.954
Cross Validation Score (Train)	0.952
Cross Validation Score (Test)	0.956

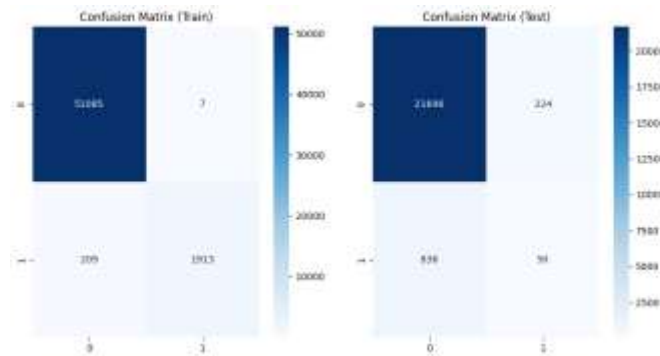

Fig. 4 Confusion matrix of random forest model without using the hybrid basic filter-based method

B. Creating a Random Forest Model Using the Hybrid Basic Filter-Based Method

In our approach, we utilized hybrid basic filter-based methods to develop a model, wherein we employed feature selection using our hybrid method, selecting 184 features, and conducted predictions using the Random Forest algorithm. As evident in Table 2 and Figure 5, metrics were obtained using only 49.86% (184 features) of the total features, as opposed to using all features (369 features). Remarkably, the metrics obtained using this reduced feature set closely resembled those achieved without employing the hybrid method for feature selection. However, it is crucial to note that this reduced feature set resulted in significant advantages in terms of time and cost. By leveraging the hybrid method for feature selection, we achieved comparable performance with a substantially reduced computational burden and resource expenditure, highlighting the efficiency and practicality of our approach in handling large datasets with improved scalability and cost-effectiveness.

Table 2. Metrics of random forest model using the hybrid basic filter-based method

Number of Features Used: 49.86% (184 Feature)	
Accuracy Train	0.996
Accuracy Test	0.954
R²	0.983
R² Train	0.996
R² Test	0.954
Cross Validation Score (Train)	0.952
Cross Validation Score (Test)	0.956

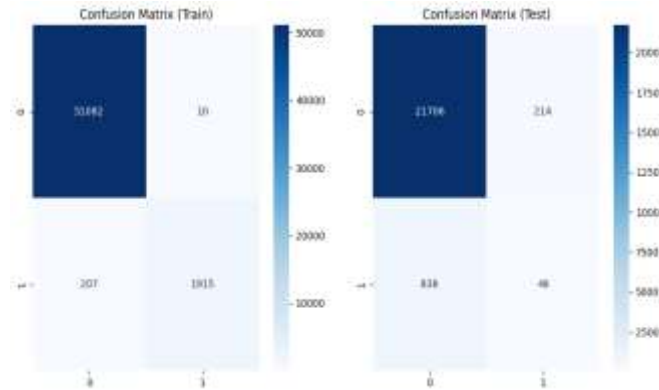

Fig. 5 Confusion matrix of random forest model using the hybrid basic filter-based method

C. Creating a Random Forest Model Tuned Using the Hybrid Basic Filter-Based Method

In our methodology, we employed hybrid basic filter-based methods to develop a model, incorporating feature selection through our hybrid approach, which identified 184 features for prediction using the Random Forest algorithm. Importantly, we refined this approach through tuning processes, optimizing hyperparameters specific to Random Forest for this problem. Following hyperparameter optimization, we identified the best parameters for Random Forest, enabling accurate predictions. Notably, as depicted in Table 3 and Figure 6, using only 49.86% (184 features) of the total features yielded metrics that outperformed those obtained without employing the hybrid method for feature selection and even outperformed metrics obtained from untuned hybrid methods. This underscores the effectiveness of our hybrid approach, showcasing its ability to significantly enhance model performance by selecting relevant features and optimizing algorithm parameters, thereby improving prediction accuracy while reducing computational resources and costs.

Table 3. Metrics of random forest model tuned using the hybrid basic filter-based method

Number of Features Used: 49.86% (184 Feature)	
Accuracy Train	0.961
Accuracy Test	0.961
R²	0.983
R² Train	0.996
R² Test	0.953
Cross Validation Score (Train)	0.960
Cross Validation Score (Test)	0.961

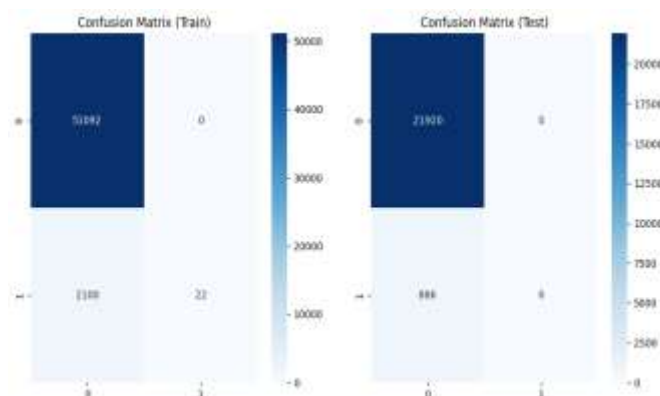

Fig. 6 Confusion matrix of random forest model tuned using the hybrid basic filter-based method

IV. CONCLUSION

In conclusion, our study underscores the significance of feature selection in predictive modelling. As depicted in Figure 7, Initially, by utilizing all features (369 features, i.e., 100%) without employing basic filter-based methods, we achieved a prediction accuracy of 0.956 using the Random Forest algorithm. Subsequently, employing hybrid basic filter-based methods and selecting 184 features (49.86%) led to a comparable prediction accuracy of 0.956, highlighting the effectiveness of feature reduction in improving efficiency without compromising accuracy. However, following model tuning processes to optimize Random Forest hyperparameters with the same 184 features, the prediction accuracy significantly improved to 0.961. This demonstrates the pivotal role of model refinement in enhancing predictive performance. Our findings underscore the importance of both feature selection and model tuning in achieving optimal predictive accuracy while minimizing computational resources and time.

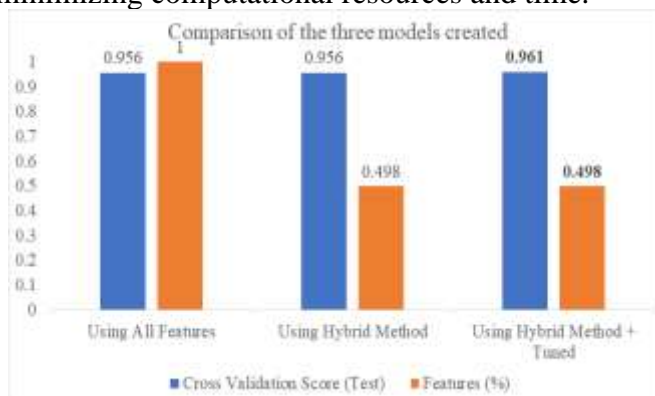

Fig. 7 Comparison of the three models created

REFERENCES

- [1] Tarczy-Hornoch P. and Minie M., "Bioinformatics challenges and opportunities," *Medical Informatics: Knowledge Management and Data Mining in Biomedicine*, vol. no. pp. 63-94, 2005.
- [2] Jain A.K. and Chandrasekaran B., "39 Dimensionality and sample size considerations in pattern recognition practice," *Handbook of statistics*, vol. 2, no. pp. 835-855, 1982.
- [3] Liu H. and Motoda H., *Feature selection for knowledge discovery and data mining*, Springer Science & Business Media, 2012.
- [4] Sugiyama M., *Introduction to statistical machine learning*, Morgan Kaufmann, 2015.
- [5] Luftensteiner S., Mayr M., and Chasparis G., "Filter-based feature selection methods for industrial sensor data: a review," *International Conference on Big Data Analytics and Knowledge Discovery*, pp. 242-249, 2021. pp. 242-249, 2021.
- [6] Ramchandran A. and Sangaiah A.K., *Unsupervised anomaly detection for high dimensional data—An exploratory analysis*, Elsevier, 2018.
- [7] Jimenez-del-Toro O., Otálora S., Andersson M., Eurén K., Hedlund M., Rousson M., Müller H., and Atzori M., *Analysis of histopathology images: From traditional machine learning to deep learning*, Elsevier, 2017.
- [8] Kohavi R. and John G.H., "Wrappers for feature subset selection," *Artificial intelligence*, vol. 97, no. 1-2, pp. 273-324, 1997.
- [9] Chandrashekar G. and Sahin F., "A survey on feature selection methods," *Computers & Electrical Engineering*, vol. 40, no. 1, pp. 16-28, 2014.

- [10] Zheng A. and Casari A., *Feature engineering for machine learning: principles and techniques for data scientists*, " O'Reilly Media, Inc.", 2018.
- [11] Opitz D. and Maclin R., "Popular ensemble methods: An empirical study," *Journal of artificial intelligence research*, vol. 11, no. pp. 169-198, 1999.
- [12] Kabir M.M., Islam M.M., and Murase K., "A new wrapper feature selection approach using neural network," *Neurocomputing*, vol. 73, no. 16-18, pp. 3273-3283, 2010.
- [13] Moldovan D., Cioara T., Anghel I., and Salomie I., "Machine learning for sensor-based manufacturing processes," *2017 13th IEEE international conference on intelligent computer communication and processing (ICCP)*, pp. 147-154, 2017.
- [14] Breiman L., "Bagging predictors," *Machine learning*, vol. 24, no. 2, pp. 123-140, 1996.
- [15] Breiman L., "Random forests," *Machine learning*, vol. 45, no. pp. 5-32, 2001.
- [16] Breiman L., Friedman J.H., Olshen R.A., and Stone C.J., *Classification and regression trees*, Routledge, 2017.
- [17] Biau G. and Scornet E., "A random forest guided tour," *Test*, vol. 25, no. pp. 197-227, 2016.



Is Climate Change a Hoax: Fake News Detection for Sustainability News

Serkan Özdemir*

¹Department of Information Systems, Middle East Technical University, Türkiye

*(serkano@metu.edu.tr)

Abstract – Fake news and misleading information have long been recognized as significant concerns throughout human history, perpetually challenging the integrity of information dissemination. With the pervasive rise of social media platforms, the velocity at which fake news spreads has escalated exponentially, intensifying the challenge of separating fact from fiction. Concurrently, the dimensions of fake news datasets have expanded in tandem with social media enhancements, facilitating the development of more sophisticated detection mechanisms. Of particular concern is the proliferation of deceptive climate-related news disseminated through various media channels, aimed at manipulating public perceptions and influencing behavioral patterns. This deceptive narrative underscores the urgency of implementing robust strategies to combat misinformation, especially in domains as crucial as climate science and sustainability. In this paper, a comprehensive analysis employing Support Vector Machine (SVM), Multi-Layer Perceptron (MLP), Long-Short Term Memory (LSTM), and Bidirectional Long-Short Term Memory (BiLSTM) algorithms is conducted to classify fake news effectively. The efficacy of these methodologies is assessed through a battery of evaluation metrics, including accuracy, F1-score, and Matthews Correlation Coefficient (MCC), providing insights into their respective strengths and limitations. The findings underscore the superior performance of the LSTM algorithm in detecting fake news, particularly within the context of sustainability-related articles. This discernment highlights the critical role of advanced machine learning techniques in fortifying information integrity and combating the pervasive dissemination of misinformation in contemporary discourse.

Keywords – Fake News Detection, SVM, LSTM, BiLSTM, Machine Learning, Deep Learning, Natural Language Processing

I. INTRODUCTION

Fake and misleading news and the spread of false information is an increasing concern, especially when it comes to elections [1], public safety [2], and health-related issues [3]. The concern even gets bigger with digital mediums for communication because, in America, 67% of the population gets some proportion of news from social media, especially from 3 sources, which are Facebook, YouTube, and Twitter [4]. Therefore, it is important to define the concept of fake news properly and determine a reliable and valid method to detect fake news on an online platform.

This paper investigates the following question: Do textual claim data enable the detection of sustainability-related fake news?

II. RELATED WORK

A. Fake News Detection

There are studies that address the problem of the concept of fake news and the terms that can be used as substitutes. According to Alcott and Gentzkow, the news claimed has to be purposefully fake and verifiably false in order to be classified as fake news [5]. Furthermore, Tandoc et al. emphasize two dimensions on this topic, which are facts and deceptions and their levels in written context [6]. Wardle's

perspective on the definition of fake news is generated by the content type, the motivation of the written passage, and the method of dissemination [7].

Another perspective on definition is related to the separation between fake and real news through claim verification. The literature focused on this aspect with two methods: input generation with claim context and fact-check factoring. The first method detects whether the claim is supportive or unsupportive of the generated input [8]. On the other hand, the second method checks all the claims and creates an output to determine whether the claim is real or fake [9].

B. Sustainability News

The studies on fake news detection for sustainability-related areas started as early as 1992. However, it gives the highest emphasis in 2021 by scholars in literature [10].

In their assessment of misinformation on climate change, Treen et al. draw attention to the doubt that surrounds the reality of climate change and examine the relationship between misinformation and disinformation in this context [11]. Greta Thunberg's leadership qualities are examined by Nässén and Rambaree using a systematic review of the literature that highlights her role in promoting sustainable options and bringing attention to environmental issues. They also touch on the topic of how fake news is used to undermine Thunberg's efforts [12].

C. Data Collection

The literature created datasets in the field that may generate the most impact in terms of method implementation and evaluation metrics, which are politics and entertainment news. The method for dataset collection mostly consists of scraping authenticated and labeled news data with intended output (confirmed by experts as to whether it is real or fake) from fact-checking websites [13].

Proposed datasets in the literature for news detection can be divided in terms of evaluation purposes, which are news content, social context, and spatiotemporal information. The most prominent dataset in the literature is FakeNewsNet, which focuses on all three aspects of news detection. News content data for FakeNewsNet is generated through fact-check websites such as Politifact and Gossipcop; social context data, on the other hand, is derived from user engagements in social media with fake and real news, which is labeled on fact-check websites. Spatiotemporal information data consists of time and location information for users on social media [14].

In order to apply the news content method, scholars created datasets that focused on different aspects, such as LIAR [15], NELA-GT-2018 [16], and FA-KES [13]. The LIAR dataset was developed in order to detect fake news with only linguistic inputs for a single labeled output [15]. NELA-GT, on the other hand, increases veracity with the multi-label data collection method [16]. In order to reduce the subjective labeling process, a novel labeling approach with semi-supervised fact-checking is used for FA-KES dataset development [13].

Data collection for social context relies on gathering additional user propagation data on news content data. In the literature, the CREDBANK [17] dataset investigated social context aspects with user and post-related attributes, while FacebookHoax [18] additionally took response messages into account for user posts.

D. Classification Methods

Classification methods vary in terms of major decisions that need to be taken into account in order to build a fake news classifier, which can be stated as data source selection, subset data type selection, feature engineering techniques for raw data, and machine learning model selection [19].

Major classification methods in the literature to detect fake news are divided into two groups: news content and social context. News content classification relies on expert opinions for labeling and fact-checking, and therefore, it is highly time-consuming [20]. The literature focused on this method with different algorithms such as Support Vector Machine (SVM) [21] and Logistic Regression (LR) [18].

While SVM is useful for cases where class separation is distinct, LR is convenient for datasets that consist of uniform and large features.

The social context method adds a propagation-based approach to the news content method and takes user actions into account. The method is highly dependent on social context features and complete network data [22]. Related studies in the literature can be stated as Author Credibility Signals [23] and Graph Neural Networks [24]. The first approach checks whether the author information is credible for the source [23]. The second approach, on the other hand, investigates the interrelationship between users and maps the data according to fake news spreads [24].

III. EXPERIMENTAL SETUP

A. Dataset

The dataset for this study was generated through Thomas et al.'s study, and the dataset is named CLIMATE-FEVER [25]. It includes variables such as claims, claim labels as supports, refutes, disputed and not enough information, and lastly evidences to support claim labels. The dataset was collected using a pipeline approach with two components, which are the Evidence Candidate Retrieval System and the Entailment Prediction stage. The claims were either collected through manual searches or web-scraping. There are a total of 1535 data rows from balanced sources.

The dataset distribution for claim labels differs in terms of each label. SUPPORTS have 655 data rows, while REFUTES have 253 data rows. DISPUTED and NOT_ENOUGH_INFO have 153 and 474 data rows, respectively.

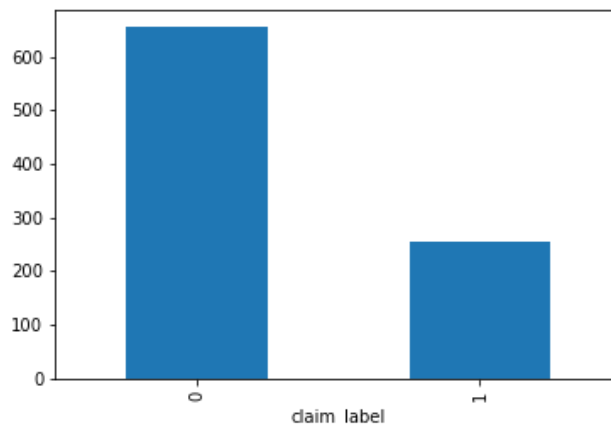

Figure 1. Claim Label Distribution

In Figure 1, the claim label distribution is presented. The 0 and 1 values represent SUPPORTS and REFUTES occurrences in the dataset. As it can be seen, there is an unbalanced distribution, which may cause bias in the case of selecting 'accuracy' as an evaluation metric. Therefore, the study also accumulated F1-score and MCC as additional evaluation metrics to prevent bias in the results.

B. Data Preprocessing

The dataset was acquired from Huggingface source as a 'parquet' file. It has no missing value for the entire dataset. The variables 'claim_id' and 'evidences' were removed from the dataset since they will not be used for the fake news detection process. There were no duplicates in the 'claim' variable.

Preprocessing textual data includes lowercase for all characters, punctuation removal, word splitting, and tokenization. The 'claim_id' values that represent DISPUTED and NOT_ENOUGH_INFO were removed from the dataset since inclusion of them is out of scope for the aim of this study.

C. Analysis

This section describes machine learning and deep learning applied to the dataset. There are two machine learning algorithms, SVM and Multi-Layer Perception (MLP), and two deep learning algorithms, Long-Short Term Memory (LSTM) and Bidirectional Long-Short Term Memory (BiLSTM), used in the study. The hyperparameter optimization was conducted in order to get the best performance out of the algorithm results.

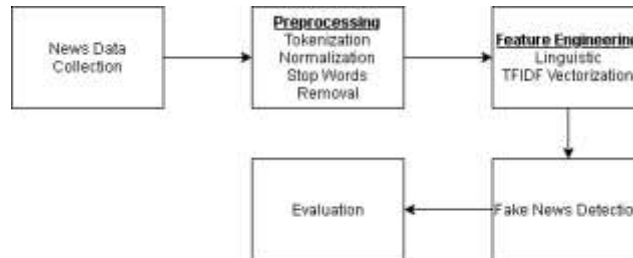

Figure 2. Methodology Flowchart

The entire methodology is depicted in Figure 2. The steps followed in the experiments include data collection, preprocessing, feature engineering, fake news detection, and evaluation.

IV. RESULTS

Although the literature focused on different aspects and features to detect fake news, this study only focused on the textual characteristics of news content data. Therefore, only one feature, 'claim', is used for fake news classification for sustainability-related news.

RQ: Do textual claim data enable the detection of sustainability-related fake news?

The textual feature is modeled with four classification algorithms, which are SVM, MLP, LSTM, and BiLSTM. Evaluation metrics for the prediction model are accuracy, F1-score, and MCC scores with cross-validation. The dataset was split as 60%, 20%, and 20% for the training set, validation set, and test set, respectively. The reason for high validation and test sets is to reduce bias in the results.

Table 1. SVM Evaluation Metric Results

Metric	Train	Validation	Test
Accuracy	0.996	0.746	0.731
F1-score	0.993	0.343	0.169
MCC	0.991	0.292	0.143

Table 1 reveals the evaluation metrics used for the SVM classification. The scores for accuracy, F1-score, and Matthews Correlation Coefficient (MCC) are 0.731, 0.169, and 0.143, respectively. The reason for score fluctuations between MCC& F1-score and accuracy is because the data is slightly unbalanced. Therefore, MCC gives the least biased evaluation result for this classification.

Table 2. MLP Evaluation Metric Results

Metric	Train	Validation	Test
Accuracy	0.998	0.680	0.725
F1-score	0.997	0.408	0.432
MCC	0.995	0.192	0.259

The MLP algorithm results are given in Table 2. It is shown that there is the same imbalance between MCC&F1-score and accuracy results. Although the accuracy score is as high as 0.725, it reduces to 0.432 for the F1 score and 0.259 for the MCC score.

Table 3. LSTM Evaluation Metric Results

Metric	Train	Validation	Test
Accuracy	0.993	0.696	0.747
F1-score	0.987	0.522	0.531
MCC	0.982	0.303	0.358

The LSTM scores are revealed in Table 3. The scores differ in terms of different evaluation metrics. The accuracy score is 0.747, the F1-score is 0.531, and the MCC score is 0.358.

Table 4. BiLSTM Evaluation Metric Results

Metric	Train	Validation	Test
Accuracy	0.991	0.674	0.709
F1-score	0.984	0.504	0.523
MCC	0.978	0.269	0.319

The results for BiLSTM algorithm is given in Table 4. The Accuracy score is 0.709, the F1-score is 0.523 and the MCC score is 0.319.

V. DISCUSSION

The results reveal that detection of fake news can be determined by several machine learning and deep learning algorithms. The best prediction results are achieved by the LSTM algorithm using MCC as an evaluation metric, with a score of 0.358. Although the results are better for all algorithms using ‘accuracy’ as an evaluation metric, since the distribution of claim label data is not balanced, there is a potential risk of bias to the results. The MCC gives more reliable results not only in balanced datasets but also in unbalanced datasets through its mathematical properties [26].

There were limitations to this study. First of all, the dataset includes only textual claim data. Therefore, the results can only be determined by the facts generated by previous researchers that label sustainability news on the dataset. Second, social context data gives extra depth to fake news detection studies. This type of data would be extra beneficial for model performance.

VI. CONCLUSION

This study analyzed the detection of sustainability-related fake news with machine learning and deep learning models based on textual news content. The results reveal that textual data is a strong indicator for detection mechanisms. The model could be further enhanced with other features related to social context cues in the future.

REFERENCES

- [1] R. Faris, H. Roberts, B. Etling, N. Bourassa, E. Zuckerman and Y. Benkler, “Partisanship, propaganda, and disinformation: Online media and the 2016 US presidential election,” *Berkman Klein Center Research Publication*, pp. 6, 2017.
- [2] P. Dixit and R. Mac, “How WhatsApp Destroyed A Village,” *Buzzfeed News*, Retrieved December 28, 2020, from <https://www.buzzfeednews.com/article/pranavdixit/whatsapp-destroyed-village-lynchings-rainpada-india>, 2018.
- [3] D. A. Broniatowski, A. M. Jamison, S. Qi, L. AlKulaib, T. Chen, A. Benton, S. C. Quinn and M. Dredze, “Weaponized health communication: Twitter bots and Russian trolls amplify the vaccine debate,” *American journal of public health*, vol. 108, no. 10, pp. 1378-1384, 2018.
- [4] E. Shearer and J. Gottfried, “News use across social media platforms 2017,” *Pew Research Center*, vol. 7, no. 9, 2017.
- [5] H. Allcott and M. Gentzkow, “Social media and fake news in the 2016 election,” *Journal of economic perspectives*, vol. 31, no. 2, pp. 211-36, 2017.
- [6] E. C. Tandoc Jr, Z. W. Lim and R. Ling, “Defining “fake news” A typology of scholarly definitions,” *Digital journalism*, vol. 6, no. 2, pp. 137-153, 2018.
- [7] C. Wardle, “Fake news. It’s complicated,” *First Draft*, pp. 16, 2017.

- [8] J. Thorne, A. Vlachos, C. Christodoulopoulos, and A. Mittal, "FEVER: a large-scale dataset for fact extraction and verification," *arXiv preprint arXiv:1803.05355*, 2018.
- [9] S. Jiang, S. Baumgartner, A. Ittycheriah, and C. Yu, "Factoring fact-checks: Structured information extraction from fact-checking articles," In *Proceedings of The Web Conference 2020*, pp. 1592-1603, 2020.
- [10] Vasist, P. N., & Krishnan, S. "Fake news and sustainability-focused innovations: A review of the literature and an agenda for future research," *Journal of Cleaner Production*, 135933, 2023.
- [11] Treen, K. M. D. I., Williams, H. T., & O'Neill, S. J. "Online misinformation about climate change," *Wiley Interdisciplinary Reviews: Climate Change*, 11(5), e665, 2020.
- [12] Nässén, N., & Rambaree, K. "Greta Thunberg and the generation of moral authority: A systematic literature review on the characteristics of Thunberg's leadership," *Sustainability*, 13(20), 11326, 2021.
- [13] F. K. A. Salem, R. Al Feel, S. Elbassuoni, M. Jaber and M. Farah, "Fa-kes: A fake news dataset around the Syrian war," In *Proceedings of the International AAAI Conference on Web and Social Media*, vol. 13, pp. 573-582, 2019.
- [14] K. Shu, D. Mahudeswaran, S. Wang, D. Lee, and H. Liu, "Fakenewsnet: A data repository with news content, social context and dynamic information for studying fake news on social media," *arXiv preprint arXiv:1809.01286*, 8, 2018.
- [15] W. Y. Wang, "'liar, liar pants on fire': A new benchmark dataset for fake news detection," *arXiv preprint arXiv:1705.00648*, 2017.
- [16] J. Nørregaard, B. D. Horne and S. Adalı, "NELA-GT-2018: A large multi-labelled news dataset for the study of misinformation in news articles," In *Proceedings of the International AAAI Conference on Web and Social Media*, vol. 13, pp. 630-638, 2019.
- [17] T. Mitra, and E. Gilbert, "Credbank: A large-scale social media corpus with associated credibility annotations," In *Proceedings of the International AAAI Conference on Web and Social Media*, vol. 9, no. 1, 2015.
- [18] E. Tacchini, G. Ballarin, M. L. Della Vedova, S. Moret and L. de Alfaro, "Some like it hoax: Automated fake news detection in social networks," *arXiv preprint arXiv:1704.07506*, 2017.
- [19] L. Bozarth and C. Budak, "Toward a Better Performance Evaluation Framework for Fake News Classification," In *Proceedings of the International AAAI Conference on Web and Social Media*, vol. 14, pp. 60-71, 2020.
- [20] S. Kwon, M. Cha, K. Jung, W. Chen and Y. Wang, "Prominent features of rumor propagation in online social media," In *2013 IEEE 13th International Conference on Data Mining*, pp. 1103-1108, 2013.
- [21] K. M. Yazdi, A. M. Yazdi, S. Khodayi, J. Hou, W. Zhou and S. Saedy, "Improving Fake News Detection Using K-means and Support Vector Machine Approaches," *International Journal of Electronics and Communication Engineering*, vol. 14, no. 2, pp. 38-42, 2020.
- [22] Y. H. Huang, T. W. Liu, S. R. Lee, F. H. Calderon Alvarado and Y. S. Chen, "Conquering Cross-source Failure for News Credibility: Learning Generalizable Representations beyond Content Embedding," In *Proceedings of The Web Conference 2020*, pp. 774-784, 2020.
- [23] N. Sitaula, C. K. Mohan, J. Grygiel, X. Zhou and R. Zafarani, "Credibility-based fake news detection," In *Disinformation, Misinformation, and Fake News in Social Media*, pp. 163-182, 2020.
- [24] H. Liao, Q. Liu, and K. Shu, "Incorporating User-Comment Graph for Fake News Detection," *arXiv preprint arXiv:2011.01579*, 2020.
- [25] Diggelmann, T., Boyd-Graber, J., Bulian, J., Ciaramita, M., & Leippold, M. "Climate-fever: A dataset for verification of real-world climate claims," *arXiv preprint arXiv:2012.00614*, 2020.
- [26] Chicco, D., & Jurman, G. (2020). The advantages of the Matthews correlation coefficient (MCC) over F1 score and accuracy in binary classification evaluation. *BMC genomics*, 21(1), 1-13.



Comparative Analysis of Machine Learning Models for Email Spam Detection

Abdulazeez Mousa¹ *, TÜRKER TUNCER² and FATİH ÖZYURT²

¹Computer Science Department/Nawroz University, Iraq

²Software Engineering Department/Firat University, Turkey

*(abdulazizmoosa93@gmail.com)

Abstract – Since the advent of the digital age, email has evolved into an indispensable medium for communication in both personal and professional contexts. The development of sophisticated spam detection systems has become necessary as a result of the rise in the number of unwanted spam emails. In this study, a number of different machine learning models are subjected to a comprehensive analysis in order to assess how efficient they are in detecting spam. More specifically, the study investigates Naive Bayes, Logistic Regression, and a unique Hybrid Model that incorporates the advantages of several different approaches. In order to evaluate the performance of the models in actual email traffic scenarios, the assessment criteria consist of accuracy, precision, recall, F1-scores, and computational efficiency. The intended outcome is to determine how well the models work. Through extensive testing and comparison, the research intends to identify insights that can improve spam filtering systems, hence improving the security of user inboxes and the overall security of communication. The selection of the most successful model by the study contributes to the field of cybersecurity by affording developers and IT professionals the opportunity to receive direction in the process of developing robust spam detection systems. The findings have implications for applications involving machine learning and text classification, highlighting the value of accuracy and efficiency in these areas. This paper not only provides an overview of the current state of spam detection technology, but it also lays the groundwork for future advancements in the fight against electronic spam.

Keywords – Spam Detection, Machine Learning, Naive Bayes, Logistic Regression, Hybrid Model, Neural Networks, Text Classification.

I. INTRODUCTION

Compare the efficiency of conventional machine learning models with a modern deep learning method. Email has become an essential communication tool in personal and business settings. Email's widespread use has made it a regular target for unwanted and harmful content, referred to as spam. Spam detection is essential for information security and digital hygiene, not only for convenience. The continuous development of spam content, which includes both annoying advertisements and advanced phishing schemes, presents substantial difficulties. Spam's inherent resilience necessitates sophisticated and clever approaches for detection and filtration.

Text categorization, a branch of machine learning, provides effective strategies for detecting spam. Machine learning systems can be trained to identify spam patterns by studying extensive datasets of tagged emails. This method automates the detection process and improves it by utilizing algorithms that may learn and boost their performance over time. Several machine learning models, such as Naive Bayes classifiers, Logistic Regression, and intricate neural networks, have been used to accurately categorize emails.

The study's objective is to assess and contrast the effectiveness of several machine learning models for spam identification. We will analyze the effectiveness of Naive Bayes, Logistic Regression, and a Hybrid Model that integrates various algorithms through a vote system. We will also investigate the use of a neural network model to determine if it is appropriate for this task. The study aims to achieve the following

- Assess the compromises related to accuracy, precision, recall, and F1-score.
- Evaluate the algorithms' capacity to extrapolate from training data to unfamiliar real-world emails.
- Determine the best efficient model for real-time spam detection in a live operating setting.

We want to share significant insights in the field of spam detection and offer recommendations for the creation of more accurate and robust spam filtering systems through this comparative investigation.

II. RELATED WORK

The growing area of spam identification has witnessed numerous machine learning and deep learning methods being used to reduce the influx of unwanted emails. An important systematic research of deep-learning-based phishing email detection highlights the effectiveness of deep learning algorithms in identifying phishing efforts, which are commonly a type of spam emails [1]. This article highlights the advanced capabilities of deep learning models in detecting subtle patterns that conventional algorithms may overlook.

Another line of research is examining the effectiveness of various machine learning methods for classifying email spam. This study critically analyzes different models' capacity to distinguish between spam and non-spam emails [2], emphasizing the advancements and effectiveness of algorithms such as Naive Bayes and Logistic Regression, known for their simplicity and efficiency.

A new spam email detection model is proposed that combines content, sentiment, semantic, user, and spam-lexicon features, in addition to the traditional content-based feature extraction. This integrative approach proposes that combining many data dimensions can greatly improve classification accuracy, questioning the conventional dependence solely on content-based features [3].

The Naïve Bayes Classifier is widely used in email-based spam detection. The probabilistic basis of this approach has been successful in multiple research investigations [4], especially when combined with preprocessing methods and feature engineering.

The text explores the integration of machine learning with computational intelligence techniques, such as Particle Swarm Optimization, to enhance the detection process [5]. The combination of machine learning algorithms and optimization approaches is a new method for improving the accuracy of traditional spam detection classifiers.

An in-depth examination of machine learning for email spam filtering discusses different methods and the unresolved research issues in the field. This analysis demonstrates how spam detection research is always improving to combat the changing strategies of spammers [6].

Additional material expands on the analysis of spammer behavior and the many machine learning methods used to identify spam emails. This study is essential for comprehending the opponent's strategies, which is vital for creating strong detection systems [7].

Machine learning plays a crucial role in spam detection, especially in identifying spam emails [8]. The debates highlight the important role of machine learning in preserving the integrity of email communication.

Finally, machine learning techniques are now being used for spam detection in Internet of Things (IoT) devices. This development indicates the field's shift towards a more linked digital ecosystem where spam identification is crucial on multiple platforms [9].

Although progress has been made, there are still gaps in the research, especially in comparing machine learning models with deep learning approaches for spam identification. This study intends to compare classical machine learning models with deep learning techniques in an operational setting to provide insights into their real-world applicability and performance trade-offs.

III. MATERIALS AND METHOD

The diagram (Figure 1) displays a detailed flowchart outlining the process of training and assessing machine learning models, such as a neural network, for a text classification assignment focused on spam detection. Here is an analysis of the main elements :

The system begins by loading essential libraries for data processing, model training, and evaluation.

A. *The evaluation function*

`evaluate_model`, is designed to display accuracy, precision, recall, and F1-score for a specified model and test data.

B. *Data Loading and Preprocessing*

The system imports a spam dataset, chooses important columns, changes their names for better understanding, and converts the labels into a suitable format.

C. *Dataset Splitting*

The dataset is divided into training and testing sets, allocating 20% of the data for testing.

D. *Model Pipelines*

Two pipelines are established for Naive Bayes and Logistic Regression, each containing stages for vectorization, TF-IDF transformation, and the classifier. A Hybrid Model is constructed with a VotingClassifier with 'soft' voting, where it predicts the class label by selecting the argmax of the sums of the predicted probabilities.

E. *Model Training*

Each model undergoes training using the training set.

F. *Receiver Operating Characteristic (ROC) and Precision-Recall Curve Generating*

The system creates ROC curves and Precision-Recall curves for each model using the test data.

The AUC is computed for each model by calculating the area under the ROC curve.

Neural network model training involves fitting a tokenizer on the training text data and converting the texts to sequences, which are then padded to provide a consistent input size.

G. *neural network model*

Its specified with an input layer, a dropout layer, and an output layer using softmax activation for binary classification. The neural network model undergoes training for 100 epochs with a batch size of 4, while monitoring both training and validation variables.

H. *Visualizing*

the neural network's performance involves plotting the training and validation accuracy and loss across epochs.

I. *Factors to take into consideration*

- The system includes vectorization and sequence padding, which are crucial preprocessing techniques for text data before being inputted into machine learning and neural network models.

- Dropout is implemented in neural networks to reduce overfitting.

- The neural network's structure and hyperparameters are selected to achieve a compromise between model complexity and performance.

- Using `verbose=2` in the model's fit method reduces the amount of output displayed in the console during training to one line per epoch.

- The system ends by graphing the performance indicators, which is essential for understanding the findings and identifying possible problems like overfitting or underfitting.

This is a comprehensive demonstration of a standard machine learning process used for text classification, incorporating conventional machine learning algorithms and a neural network model. The evaluation and visualization of model performance are conducted extensively.

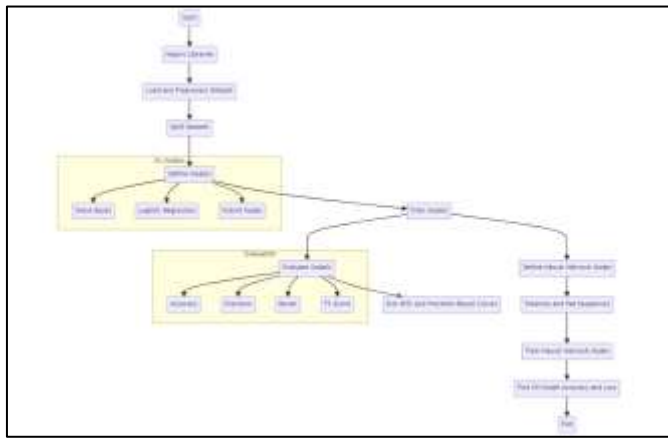

Fig. 1 Diagram of System

J. Structure and Content of the Dataset

The "spam.csv" dataset [10] contains 5,572 entries distributed across 5 columns, mainly centered on text data for spam categorization. The columns are identified as v1, v2, Unnamed: 2, Unnamed: 3, and Unnamed: 4, containing the following observations:

- v1: Specifies the classification label as either "ham" for non-spam or "spam" for spam communications.
- v2: Includes the content of the message.

K. Initial Observations

The dataset consists mainly of textual data, with v1 and v2 variables, where v1 is the target variable used for spam categorization.

Statistical Summary Variable Labels: There are two distinct labels: "ham" and "spam", with "ham" being the more common type.

Messages (version 2): The dataset has 5,169 distinct messages, showcasing the variety within the text data. The recurrence of some messages, such as "Sorry, I'll call later," indicates typical words in communication that may not be helpful in identifying spam.

The "spam.csv" dataset is an important resource for text categorization and natural language processing (NLP) research, especially in the field of spam detection. The main goal of this dataset is to categorize messages as either spam or ham. This procedure includes text data preparation, feature extraction using methods such as TF-IDF or word embeddings, and utilizing machine learning models like Naive Bayes, SVM, or deep learning techniques.

L. Important academic activities may involve

Text preprocessing involves cleaning text data, addressing missing values, tokenization, and eliminating stop words.

Feature Engineering involves converting text into a format suitable for machine learning algorithms by utilizing methods such as bag-of-words or TF-IDF.

Training and evaluating models by using different classification algorithms and assessing their performance based on measures like accuracy, precision, recall, and F1 score.

This dataset provides a great chance to delve into the intricacies of text data, comprehend the difficulties in spam detection, and create models that can effectively classify messages. Exploring modern approaches like NLP and deep learning can improve classification performance due to the unstructured nature of text data.

IV. RESULTS

All three models—Hybrid, Logistic Regression, and Naive Bayes—have metrics that allow us to assess their performance on several evaluation measures, such as F1-Score, Precision, Accuracy, and Recall as Table 1 shown.

Table 1. Model Metrics

Model	Accuracy	Precision	Recall	F1-Score
Naive Bayes	0.962331838565	1.0	0.72	0.837209302326
Logistic Regression	0.965919282511	0.991228070175	0.753333333333	0.856060606061
Hybrid Model	0.965022421525	1.0	0.74	0.850574712644

Accuracy is the ratio of correct results (true positives and true negatives) to the total number of instances analyzed. It provides a broad indication of the model's accuracy rate.

- Logistic Regression had the greatest accuracy of 0.9659, making it the most generally accurate model in all cases.

- The Hybrid Model has an accuracy of 0.9650, which is higher than Naive Bayes but lower than Logistic Regression.

- Naive Bayes achieved an accuracy of 0.9623, which is the lowest among the models but still relatively high.

Precision is the ratio of real positive results to all positive predictions. It demonstrates the model's capacity to prevent false positives.

- Both Naive Bayes and the Hybrid Model have a precision of 1.0, indicating they accurately predict positive cases without any false positives.

- Logistic Regression exhibits a somewhat lower precision of 0.9912, however, it remains notably high, suggesting minimal occurrences of false positives.

A. Recall (Sensitivity)

Recall quantifies the ratio of true positive outcomes among all existing positive instances. This signifies that the model is capable of identifying every positive sample.

- Logistic Regression achieved the highest recall rate of 0.7533, suggesting it excels in recognizing positive events among the actual positives.

- The Hybrid Model exhibits a marginally reduced recall rate of 0.74 compared to Logistic Regression.

- Naive Bayes exhibits the lowest recall rate of 0.72, suggesting that it fails to identify a higher number of positive cases compared to the other models.

B. F1-Score

The F1-Score is the harmonic mean of precision and recall, providing a balanced measure, especially effective in cases with imbalanced class distribution.

- Logistic Regression achieved the highest F1-Score of 0.8561, demonstrating the optimal balance between precision and recall.

- The Hybrid Model's F1-Score of 0.8506 is marginally lower, suggesting a comparable equilibrium.

- Naive Bayes achieved the lowest F1-Score of 0.8372, indicating that it has a less optimal trade-off between precision and recall when compared to the other models.

Logistic Regression is the most well-rounded model, with the highest accuracy and F1-Score, suggesting it excels across all measures.

The Hybrid Model closely adheres to a solid mix of accuracy and F1-Score, making it a viable competitor, particularly in situations where minimizing false positives is essential.

Naive Bayes exhibits great accuracy and flawless precision while having the lowest recall and the F1 score. It is especially useful in situations where false positives are strongly discouraged.

Each model has unique strengths that may be more suitable depending on the specific work needs, such as prioritizing precision over recall or aiming for overall accuracy across several instances.

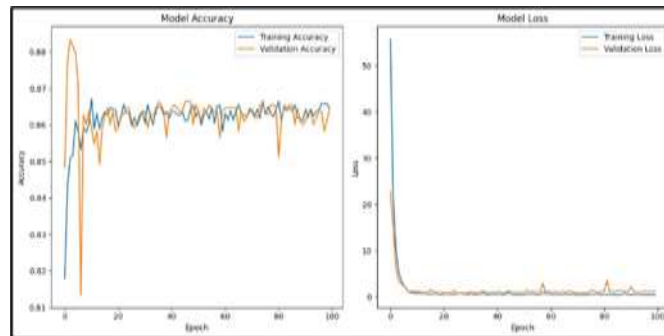

Fig. 2 Model Accuracy and loss Graph

The graphs (Figure 2) depict the training and validation accuracy and loss of a machine learning model across 100 epochs:

C. Graph depicting model Accuracy

The model accuracy graph shows that the training and validation accuracy remain similar over epochs, suggesting effective generalization without notable overfitting. Visible fluctuations in validation accuracy are normal when the model encounters fresh, unseen data. The model's accuracy plateaus after a certain point, indicating that it may have reached its performance limit with the existing architecture and hyperparameters.

D. Graph depicting model loss

There is a significant reduction in both training and validation loss at the beginning of the training process, which is a common occurrence as the model starts to learn from the data. The decreasing training loss stabilizes, indicating successful model learning. The validation loss exhibits greater variability, which is a common occurrence. The validation loss seems to decrease to its lowest point and remain stable after a specific number of epochs, with occasional spikes indicating potential learning or adjustments to the validation set.

E. General Observations

The graphs suggest that the model is not overfitting as the validation metrics closely mirror the training characteristics. If the model were overfitting, we would anticipate the validation accuracy to diverge and decline, or the validation loss to increase as the epochs progress.

The model has strong convergence when the loss diminishes and accuracy improves or stabilizes.

The alignment between the training and validation curves suggests a suitable balance between the dataset size and the model's intricacy.

F. Potential Actions

Early Stopping is a technique used to end the training process if the validation loss does not improve for a specified number of epochs, which can be helpful when computational resources or time are limited. Hyperparameter tuning involves adjusting parameters like learning rate, batch size, or model complexity to potentially enhance the model's performance. Regularization techniques such as dropout or L2 regularization could be used to address overfitting if it becomes a concern in the future. Data Augmentation can improve a model's ability to generalize by helping it learn more resilient characteristics.

The model appears to function effectively with the current configuration, but there is always the opportunity to explore modifications in order to potentially enhance its performance further, as is common in machine learning.

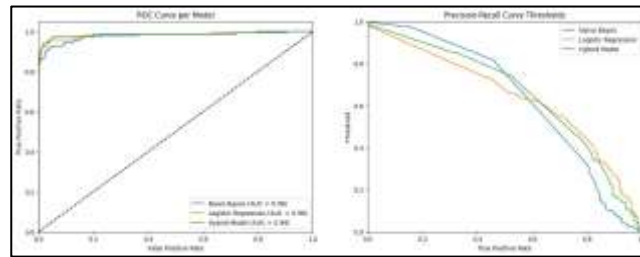

Fig. 3 ROC Curve of Models

The figure 3 displays two plots: a Receiver Operating Characteristic (ROC) curve and a Precision-Recall (PR) curve for three models — Naive Bayes, Logistic Regression, and a Hybrid Model. These are typical visual representations used to assess the effectiveness of categorization models.

ROC Curve Analysis involves plotting the true positive rate (TPR) versus the false positive rate (FPR) at different threshold levels. A test is more accurate when its curve closely aligns with the left-hand and top borders of the ROC space.

Area Under the Curve (AUC): This metric evaluates the model's capacity to differentiate across classes and serves as a condensed representation of the ROC curve. A model with a higher AUC value demonstrates more accuracy in distinguishing between 0s and 1s in its predictions. An AUC of 0.5 signifies no discrimination, meaning random chance, whereas a value of 1 represents complete discrimination.

All three models on the graph exhibit outstanding performance, with Naive Bayes and Logistic Regression achieving an AUC of 0.98 each, and the Hybrid Model slightly outperforming both with an AUC of 0.99. All models exhibit a high level of separability.

Analysis of Precision-Recall Curve:

The Precision-Recall Curve illustrates the balance between precision and recall across various threshold settings. A large area under the curve indicates high recall and high accuracy, with high precision corresponding to a low false positive rate and high recall corresponding to a low false negative rate.

The PR plot's curves demonstrate that the models achieve a trade-off between precision and recall at various levels. Usually, when the threshold rises, precision goes up while recall goes down, and vice versa.

The proximity of the curves indicates that the three models have comparable performance in terms of precision and recall trade-offs.

G. Comparison of Models

The Hybrid Model demonstrates a tiny edge in the ROC AUC statistic, indicating its superior ability to differentiate between positive and negative classifications.

The precision-recall curves are similar enough that the actual difference in performance across the models might be negligible, particularly within specific threshold intervals.

All models demonstrated outstanding performance metrics, with the Hybrid Model showing a little superiority.

The decision between models may depend on the particular environment in which they are utilized and the trade-offs between false positives and false negatives.

For datasets with significant imbalance, the precision-recall curve can provide more insightful information compared to the ROC curve.

If you prioritize achieving the maximum discriminative performance, the Hybrid Model would be the optimal choice based on these visual assessments. For applications where precision and recall balance is crucial, all models are competitive. The decision may be influenced by characteristics like model complexity, interpretability, and computing time.

V. DISCUSSION

Comparing machine learning models to identify their strengths, flaws, and potential areas for enhancement. The text examines how the findings impact practical spam detection systems, taking into account issues such as model correctness, computing efficiency, and the balance between various performance indicators (e.g., precision vs. recall). The debate could also consider merging or creating new models to improve spam detection skills.

VI. CONCLUSION

Summarizes the main results of the comparison investigation, highlighting the Logistic Regression model as the most versatile choice for spam detection based on different criteria. The statement recognizes the distinct advantages of each model, indicating that the selection of a model may be influenced by certain operational requirements or preferences. The conclusion may suggest additional research to enhance model accuracy and efficiency, and to investigate novel techniques for spam detection in a constantly changing digital environment.

ACKNOWLEDGMENT

Special thanks for Associate Dr FATİH ÖZYURT.

REFERENCES

- [1] Thakur, K., Ali, M. L., Obaidat, M. A., & Kamruzzaman, A. (2023). A Systematic Review on Deep-Learning-Based Phishing Email Detection. *Electronics*, 12(21), 4545.
- [2] Jazzar, M., Yousef, R. F., & Eleyan, D. (2021). Evaluation of machine learning techniques for email spam classification. *International Journal of Education and Management Engineering*, 11(4), 35-42.
- [3] Zamir, A., Khan, H. U., Mehmood, W., Iqbal, T., & Akram, A. U. (2020). A feature-centric spam email detection model using diverse supervised machine learning algorithms. *The Electronic Library*, 38(3), 633-657.
- [4] Malhotra, P., & Malik, S. (2022). Spam Email Detection Using Machine Learning and Deep Learning Techniques. Available at SSRN 4145123.
- [5] Dada, E. G., Bassi, J. S., Chiroma, H., Adetunmbi, A. O., & Ajibuwa, O. E. (2019). Machine learning for email spam filtering: review, approaches and open research problems. *Heliyon*, 5(6).
- [6] Kaddoura, S., Chandrasekaran, G., Popescu, D. E., & Duraisamy, J. H. (2022). A systematic literature review on spam content detection and classification. *PeerJ Computer Science*, 8, e830.
- [7] Jáñez-Martino, F., Alaiz-Rodríguez, R., González-Castro, V., Fidalgo, E., & Alegre, E. (2023). A review of spam email detection: analysis of spammer strategies and the dataset shift problem. *Artificial Intelligence Review*, 56(2), 1145-1173.
- [8] Charanarur, P., Jain, H., Rao, G. S., Samanta, D., Sengar, S. S., & Hewage, C. T. (2023). Machine-Learning-Based Spam Mail Detector. *SN Computer Science*, 4(6), 858.
- [9] Ahmed, N., Amin, R., Aldabbas, H., Koundal, D., Alouffi, B., & Shah, T. (2022). Machine learning techniques for spam detection in email and IoT platforms: Analysis and research challenges. *Security and Communication Networks*, 2022, 1-19.
- [10] Athira, G. S. (n.d.). Email Spam Detection. Kaggle. Retrieved February 29, 2024, from <https://www.kaggle.com/code/athirags/email-spam-detection/notebook>



Elektrik Dağıtım Şebekelerinde Blokzinciri ve Yapay Zekâ Teknolojileri ile Dijital Dönüşümün Sağlanması

¹Muhammet Yemen Boyacı, ¹Doğan Çelik

¹Elektrik Elektronik Mühendisliği / Fen Bilimleri Enstitüsü, Van Yüzüncü Yıl Üniversitesi, Türkiye

¹Elektrik Elektronik Mühendisliği / Fen Bilimleri Enstitüsü, Van Yüzüncü Yıl Üniversitesi, Türkiye

*(dogancelik@yyu.edu.tr)

Özet – Enerji dağıtım şebekeleri enerji taleplerinin artması ile tüketici bağlantı taleplerinin etkin bir şekilde değerlendirilmesi ve yönetilmesi büyük önem taşımaktadır. Bu çalışma ile elektrik dağıtım şebekesinde tüketici bağlantı taleplerinin karşılanması sürecinde blokzinciri teknolojisi sayesinde daha etkin ve verimli bir şekilde yönetilmesi için python dili ve yapay zekâ kullanılarak geleneksel yöntemden farklı olarak hızlı, şeffaf ve güvenilir bir şekilde taleplerin karşılanması bir model üzerinde sağlanmıştır. Blokzinciri tabanlı bir altyapı ile tüketici talepleri şebeke karakteristiğine göre değerlendirilerek uygun güç bilgisi tespit edilen en yakın şebeke unsuruna bağlantı uygunluğu verilmiştir. Bu sayede sürecin takip edilebilirliği artırılabilir, riskler azaltılarak sürecin şeffaflığı sağlanmıştır. Ayrıca akıllı sözleşme kullanımıyla bağlantı taleplerinin otomatik olarak değerlendirilmesi ve onay süreçlerinin hızlanması sağlanır. Elektrik dağıtım şebekesi unsurlarının mevcut güç, elektriksel karakteristik ve konum bilgileri ile python dili ile oluşturulan blokzinciri altyapısına yeni gelen talebi yapay zekâ karar ağacı algoritmasına göre değerlendirdikten sonra mesafesi en kısa ve karakteristiği en uygun şebeke elemanına ekleyerek yeni bir blok oluşturması mantığı ile sistem çalışmaktadır. Bu çalışma ile mevcut yöntemden farklı olarak tüketici bağlantı taleplerinin hızlı ve etkin bir şekilde değerlendirilerek, artırılmış şeffaflık, geliştirilmiş güvenlik avantajları ile daha verimli şebeke yönetimi ve maliyetlerin azaltılması konusunda etkin faydalar sağlamaktadır. Yapay zekâ karar ağacı kullanılarak gerçekleştirilecek olan değerlendirme, elektrik şebekelerinin kapasitesinin daha etkin bir şekilde yönetilmesine ve tüketicilere daha hızlı ve güvenilir enerji bağlantı hizmeti sunulmasına olanak tanır ve önemli faydalar sağlamaktadır.

Blokzinciri, Elektrik Dağıtım Şebekesi, Kriptografi, Python, Makine Öğrenmesi, Yapay Zekâ

I. GİRİŞ

Elektrik dağıtım şebekelerinde tüketici bağlantı taleplerinin hızlı ve etkili bir şekilde değerlendirilmesi, elektrik tedarikçileri ve tüketiciler arasında sorunsuz bir iş birliğini sağlamak için önemlidir. Blokzinciri ve yapay zekâ teknolojisi, güvenlik, şeffaflık ve otomatikleştirme gibi özellikleri ile bu süreci iyileştirme potansiyeline sahiptir. Görüntü işleme, yapay zekâ modeli eğitime ya da ağ analizleri gibi işlemci maliyeti yüksek işlemler için alternatif olarak hibrit yaklaşımların kullanıldığı görülmektedir. Hibrit yaklaşımda maliyetli hesaplamalar blokzinciri ağı dışında yapılır, güvenli iletişimi sağlayacak gereksinimler ise blokzinciri ağı içerisinde yapılmaktadır. Yapay zekanın blokzincire entegrasyonu ile daha güvenilir, maliyeti ve işlem sayısı daha düşük olarak stabil çalışan sistemlerdir [1]. Blokzinciri teknolojisinin veri güvenliği, zaman ve maliyet verimliliği açısından enerji ticaretinde aktif olarak kullanılmaya başlanmıştır [2]. Kuzior ve ark. (2022) tarafından yapılan araştırma, artan çevresel kaygılar, enerji krizleri ve yükselen enerji maliyetleri karşısında enerji yönetimini optimize etmenin önemini vurgulanmaktadır. Bu bağlamda, blokzinciri ve yapay zeka gibi yeni dijital teknolojilerin potansiyel katkıları incelenmektedir. Araştırmalar, Scopus ve Web of Science veri tabanlarından elde edilen verileri analiz etmek için VOSviewer yazılımını kullanmaktadır. Elde edilen çalışmalar bu teknolojilerin enerji yönetiminde yaygınlaşmasına dikkat çekse de, “enerji verimliliği” ve “blokzinciri/blockchain” terimlerini içeren sınırlı sayıda çalışma olduğunu

ortaya koymaktadır. Bulgular, yapay zekanın enerji yönetimine hızla entegre edildiğini ve daha verimli ve güvenli enerji üretim yöntemlerine katkıda bulunduğunu göstermektedir [3].

Literatürde yapılan çalışmalar, yapay zekâ ve blokzinciri entegrasyonunun giderek daha fazla kabul edildiğini ve bu birleşimin avantajlarını ana hatlarıyla ortaya koymaktadır. Tedarik zincirleri, finansal hizmetler, sağlık hizmetleri, yaşam bilimleri, akıllı şebekeler, tarım ve araçların interneti gibi birden fazla sektörde gerçek dünya uygulamalarına odaklanmaktadır. Ayrıca, belgede gizlilik, güvenlik, akıllı sözleşme güvenliği, deterministik uygulama sonuçları, ölçeklenebilirlik, zincir dışı ve zincir içi veri depolama gibi kritik konular da ele alınmaktadır. Blokzinciri ve yapay zekâ teknolojilerini birleştirmenin dönüştürücü potansiyeli, çeşitli endüstrilerdeki uygulamaları ve etkileri ile bu teknolojilerin birleşimi, gelecekteki inovasyonlara önemli katkılarda bulunabilir ve endüstriler arasında daha güvenli, şeffaf ve etkili bir veri yönetimi sağlayabilir [4], [5], [6].

II. MATERYAL VE YÖNTEM

Elektrik dağıtım şebekesine kullanıcı bağlantı taleplerinin değerlendirilmesi için ilgili mevzuat kapsamında değerlendirilerek dağıtım şirketi tarafından verilir. Bu çalışmada, Python kodu ile şebeke unsurları blok olarak tanımlanarak Python kodu ile oluşturulan karar ağacı için eğitim verisi olarak kullanılmıştır. Yönetmelik kapsamında kullanıcıdan koordinat bilgisi ve güç değerleri alınarak girilen koordinat bilgileri geçerliliği kontrol edilir ve geçersiz bir değer varsa kullanıcıya hata mesajı iletilir. Aynı şekilde, girilen güç değerleri pozitif olup olmadığı kontrol edilir ve negatif bir değer varsa kullanıcıya hata mesajı iletilir. Kullanıcının girdiği uygun koordinat ve güç değerleriyle yeni bir blok oluşturulur. Mevcut bloklar içerisinde gücü yeni eklenen bloktan daha büyük olan bloklar tespit edilir. Bu tespit edilen bloklar, koordinatlarına göre yeni oluşturulan bloğa en yakın olan mesafeyi hesaplayacak bir fonksiyon kullanılarak belirlenir. Gücü yeni girilen bloktan büyük olan ve koordinatları yeni girilen bloğa en yakın olan blok tespit edilir. Yeni oluşturulan blok, tespit edilen bloğa eklenir. Yeni blok ekledikten sonra gücü büyük olan bloktan yeni eklenen bloğun gücü düşürülür.

A. Blokzinciri ve Yapay Zekâ

Günümüzde teknolojinin hızla ilerlemesi ve dijital dönüşümün artmasıyla birlikte blokzinciri teknolojisi adını sıkça duyduğumuz, inovatif ve güvenilir bir veri yönetim sistemi haline gelmiştir. Merkezi olmama, şeffaflık ve izlenebilirlik, güvenlik ve kriptografi, konsensüs mekanizması, dağıtılmış defter prensipleri, blokzinciri teknolojisinin temelini oluşturarak, birçok sektörde devrim niteliğinde çözümler sunmaktadır. Elektrik dağıtım şebekelerinde şebeke yapıları değerlendirildiğinde merkezi olma yöntemi önemli bir rol almaktadır. Bu durumda blokzinciri temel prensipleri ile pik yükü analiz edilerek şebeke yatırımlarından tasarruf edilebilmektedir [5]. Modern şebekelerde kontrol ve iletişim teknolojileri ile birlikte blokzinciri entegrasyonunu, sürdürülebilir enerji arz zincirinin yeniden yapılandırılması için teknolojik, sosyal ve ekonomik yenilikleri desteklemektedir [6].

Yapay zekâ karar ağacı ise bir problemi çözmek veya bir sınıflandırma görevini yerine getirmek amacıyla kullanılan bir makine öğrenimi algoritmasıdır. Bu algoritma, bir veri kümesindeki desenleri öğrenir ve yeni, bilinmeyen verilere dayalı olarak kararlar alabilir. Karar ağacı yönteminin matematiksel modeli, entropi ve bilgi kazancı gibi kavramlara dayanır. Entropi, bir veri kümesinin ne kadar düzensiz veya rastgele olduğunu ölçen bir değerdir. Bilgi kazancı ise bir özelliğin bir veri kümesinin entropisini ne kadar azalttığını ölçer [7]. Karar ağacı oluşturma algoritmaları, en yüksek bilgi kazancı sağlayan özelliği seçerek ve bu özelliğe göre veri kümesini bölerek çalışır. Bu işlem, veri kümesindeki tüm örnekler aynı sınıfa ait olana veya daha fazla bölünme mümkün olana kadar devam eder [8], [9], [10], [11], [12], [13], [14].

B. Python Kullanarak Sistemin Tasarlanması

Sistemin tasarımı için örnek şebeke oluşturularak şebeke verileri ile sistemin eğitiminin yapılması gerekmektedir. Tasarlanan ve sentetik verilerden oluşan şebeke unsurlarına ait şebeke unsuru adı, karakteristiği, gerilim seviyesi (V), AG/OG durumu, koordinat bilgisi X, koordinat bilgisi Y, meskûn mahal bilgisi, maximum kapasite ve mevcut kapasite bilgilerinden oluşan veri seti sınırlı sayıda veriden oluştuğu için yine python kodu kullanılarak gerçeğe yakın sentetik veriler oluşturulmuştur. Şekil 1' de verilen ve sistem algoritmasının bir kısmını oluşturan algoritma ile sistem ilgili mevzuata göre değerlendirilmektedir.

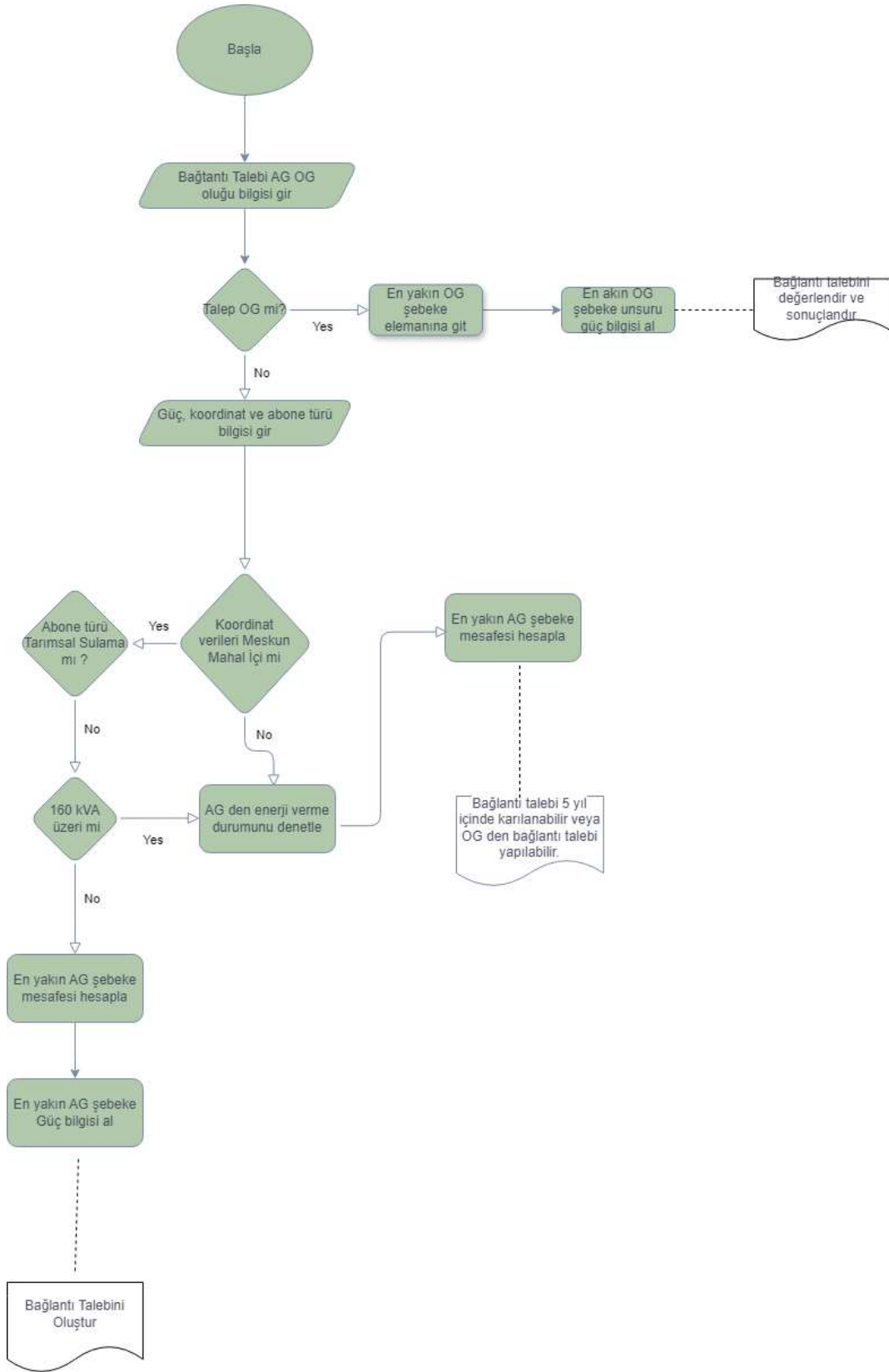

Şekil 1. Önerilen sistemin algoritması

Python kodu ile blokzinciri oluşturma ve yapay zekâ karar araçları metodu ile sistemin tasarımı için ilk olarak, kodun başında gerekli kütüphaneler içeri aktarılır. Bu kütüphaneler, veri manipülasyonu, model oluşturma, eğitim-test seti bölme, doğruluk değerlendirmesi ve görselleştirmeyi kolaylaştıran araçları içerir.

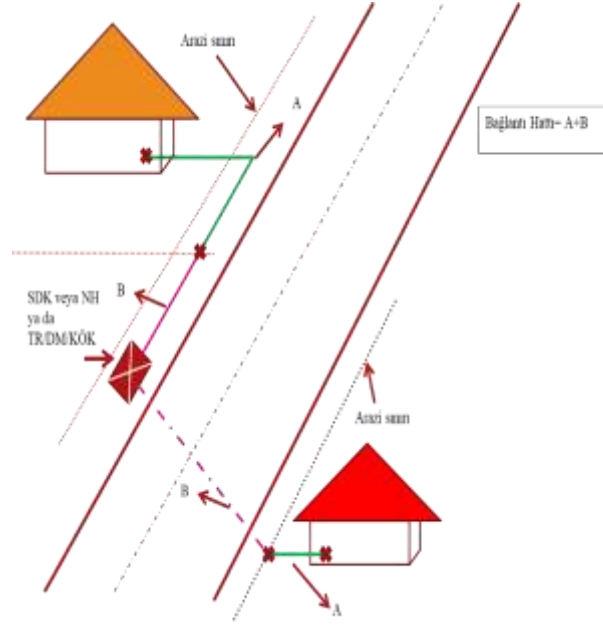

Şekil 3. Tüketici bağlantı hattı sınırları

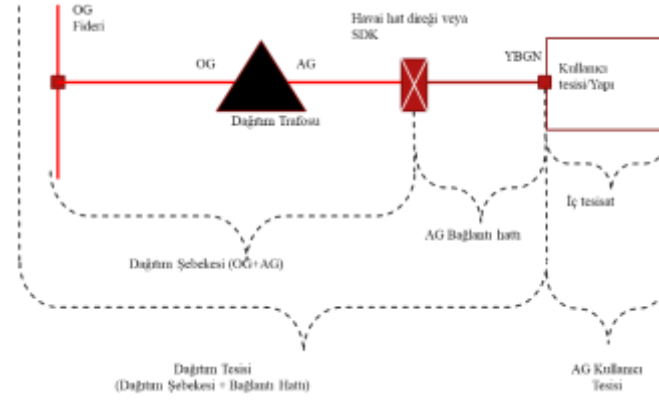

Şekil 4. Branşman hattı

III. BULGULAR

Mevcut çalışmalardan farklılık gösteren bu çalışmada; blokzinciri teknolojisinin enerji sektöründe kullanılması genel olarak enerji piyasaları arz talebi, enerji ticareti, dağıtık enerji sistemlerinin izlenmesine, üretim sistemlerinin denetimine odaklanılırken, bu çalışma tüketici bağlantı taleplerinin değerlendirilmesi sürecine odaklanmaktadır. Akıllı sözleşmeler, taleplerin otomatik işlenmesini ve doğrulanmasını sağlayarak süreci hızlandırır ve yapay zekâ teknolojisi ile insan hatalarını azaltmaktadır. Blokzinciri tabanlı çözümün gerçek dünya senaryolarında nasıl uygulanabileceğine odaklanmaktadır. Blokzinciri mevcut sistemlerle entegrasyonu ve pratik uygulanabilirliği değerlendirmektedir. Bu çalışma teorik bir çalışmadan ziyade gerçek dünyadaki kullanılabilirliğe odaklanmaktadır. Bu çalışmada, Python dili ve yapay zekâ algoritmaları kullanılarak blokzinciri tabanlı bir altyapı oluşturulmuştur. Geleneksel yöntemlerden farklı olarak, bu altyapı sayesinde talepler hızlı, şeffaf ve güvenilir bir şekilde karşılanabilmektedir. Simülasyon sonuçları, farklı blok sayıları için doğru ve hatalı eşleşme oranlarını ortaya koymaktadır. Şebeke unsurlarından oluşan bloklar için şebeke büyüklüğüne göre eğitim ve test verilerinin artması durumunda doğru ve hatalı eşleşme durumlarına ilişkin oran Tablo 1’ de verilmiştir. Tablo 1 ile verilen veriler değerlendirildiğinde 1230 blok için 92.80% doğruluk 5280 blok için 93.28% doğruluk oranı 9245 blok için 93.51% doğruluk 11880 blok için 93.81% doğruluk 14520 blok için 94.32% doğruluk test oranlarına göre yapılan simülasyon sonuçlarına dayanarak, blokzinciri ve yapay zekâ kullanımının tüketici bağlantı taleplerinin daha etkin bir şekilde yönetilmesini sağladığını göstermektedir.

Python kodu ile tasarlanan blokzinciri ve yapay zekâ karar ağacı metoduna göre çalışan sistem için Şekil 5 ile verilen grafikte görüleceği gibi doğruluk oranı işlenen eğitim verilerinin artması ile %94.3181 gibi bir değere ulaşmıştır.

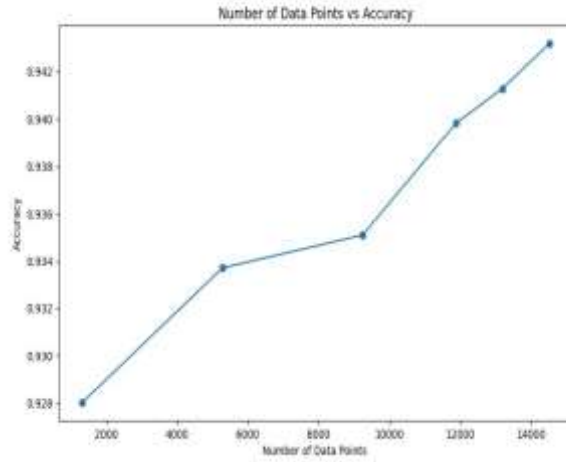

Şekil 5. Doğruluk oranı grafik çıktısı

Tablo 1. İşlenen Blok Sayısı ve Doğruluk Oranı

	Toplam blok sayısı				
	1230 blok	5280 blok	9245 blok	11880 blok	14520 blok
Test Oranı	20 (%)	20 (%)	20 (%)	20 (%)	20 (%)
Doğru Eşleşme	244 (92,8030)	982 (93,2765)	1783 (93,5100)	2229 (93,8148)	2739 (94,3181)
Toplam	264	1056	1849	2376	2964

IV. SONUÇLAR

Bu çalışma, blokzinciri ve yapay zekâ kullanımının potansiyelini vurgulamaktadır ancak gelecekte daha detaylı analizler ve uygulamalar için daha fazla çalışma gerekmektedir. Özellikle, gerçek şebeke verileri üzerinde yapılan daha kapsamlı testler ve endüstriyel ölçekteki uygulamalar, bu teknolojilerin etkinliğini daha iyi anlamamıza yardımcı olabilir. Ayrıca, enerji sektöründeki diğer yenilikçi teknolojilerin blokzinciri ve yapay zekâ ile entegrasyonu da gelecek çalışmaların odak noktalarından biri olabilir. Enerji depolama sistemleri, sürdürülebilir enerji üretimi ve enerji verimliliği gibi alanlarda bu teknolojilerin kullanımıyla ilgili daha derinlemesine araştırmalar, sektördeki geniş kapsamlı dönüşümlere olanak tanıyabilir.

Bu şekilde yapılan gelecek çalışmalar, elektrik dağıtım şebekelerindeki talep yönetimi süreçlerinin daha da optimize edilmesine ve enerji sektöründeki sürdürülebilirlik hedeflerine daha etkili bir şekilde katkıda bulunulmasına olanak tanıyabilir.

KAYNAKLAR

- [1] Acharya, V., Yerrapati, A. E., & Prakash, N. (2019). Oracle Blockchain Quick Start Guide: A practical approach to implementing blockchain in your enterprise.
- [2] Melih Fırat Yalvaç, Ali Ettehadi, (2021). Blockchain technology:its impact on energyefficiency and trade.
- [3] Kuzior, A., Sira, M., & Brozek, P. (2022). Using Blockchain and Artificial Intelligence in Energy Management as a Tool to Achieve Energy Efficiency. Virtual Economics, 5(3), 69-90
- [4] Taherdoost, H. (2022). Blockchain technology and artificial intelligence together: a critical review on applications. Applied Sciences, 12(24), 12948

- [5] Ahmet Yağmur, Samet Tonyalı,2022, Elektrik dağıtım şirketleri perspektifinden blokchain temelli enerji uygulamaları,
- [6] Ying Wu , Yanpeng Wu , Halil Cimen , Juan C. Vasquez , Josep M. Guerrero (2022) Towards collective energy Community: Potential roles of microgrid and blockchain to go beyond P2P energy trading. *Applied Energy* 314 -119003
- [7] J.R. Quinlan. C4. 5: programs for machine learning. Morgan Kaufmann, 1993.
- [8] T. Hastie, R. Tibshirani and J. Friedman. *Elements of Statistical Learning*, Springer, 2009.
- [9] Adeyemi, A., Yan, M., Shahidehpour, M., Botero, C., Guerra, A. V., Gurung, N., ... & Paaso, A. (2020). Blockchain technology applications in power distribution systems. *The Electricity Journal*, 33(8), 106817
- [10] Hua, W., Chen, Y., Qadrdan, M., Jiang, J., Sun, H., & Wu, J. (2022). Applications of blockchain and artificial intelligence technologies for enabling prosumers in smart grids: A review. *Renewable and Sustainable Energy Reviews*, 161, 112308.
- [11] Lucas, A., Geneiatakis, D., Soupionis, Y., Nai-Fovino, I., & Kotsakis, E. (2021). Blockchain technology applied to energy demand response service tracking and data sharing. *Energies*, 14(7), 1881.
- [12] Hasan, M. K., Alkhalifah, A., Islam, S., Babiker, N. B., Habib, A. A., Aman, A. H. M., & Hossain, M. A. (2022). Blockchain technology on smart grid, energy trading, and big data: security issues, challenges, and recommendations. *Wireless Communications and Mobile Computing*, 2022, 1-26.
- [13] Gupta, R., & Chaturvedi, K. T. (2023). Adaptive Energy Management of Big Data Analytics in Smart Grids. *Energies*, 16(16), 6016.
- [14] Fadi, O., Karim, Z., & Mohammed, B. (2022). A survey on Blockchain and Artificial intelligence technologies for enhancing security and privacy in smart environments. *IEEE Access*, 10, 93168-93186.



Machine learning for seismic response prediction of structures

BENBOKHARI Abdellatif ^{1,*}, BENAZOUZ Chikh ¹ and MEBARKI Ahmed ^{2,3}

¹ *Laboratoire des Travaux publics, ingénierie de Transport, environnement, Ecole Nationale supérieure des travaux publics, Kouba, Algiers, Algeria.*

² *University Gustave Eiffel, UPEC, CNRS, Laboratory Modélisation et Simulation Multi Echelle (MSME 8208 UMR), Marne-la-Vallée, France.*

³ *Nanjing Tech University (China), Permanent Guest Professor within “High-Level Foreign Talents Programme” grant.*

**(a.benbokhari@enstp.edu.dz) Email of the corresponding author*

Abstract – This paper presents a study comparing artificial neural networks (ANNs) and existing methods for estimating the seismic response of a single degree of freedom (SDOF) - known as target displacement. The study involved generating a dataset using the Nonlinear Time History Analysis (NLTHA) of elastic perfectly plastic (EPP) SDOF systems with varying initial stiffness and mass, subjected to 80 ground motions (GMs) matched to a target response spectrum.

The generated dataset was divided into three parts: 80% for training the model, 10% for assessing the prediction performance during training, and 10% for validating the performance after training. The ANN model's results were compared to four other methods for estimating the target response: the capacity spectrum method (CSM), displacement coefficient method (DCM), equivalent linearization (EL), and modified coefficient method (MCM).

The study was conducted on nine SDOFs with three different vibration periods ($T= 0.2$ sec, 0.5 sec, and 1.0 sec) and three strength reduction factors ($R= 2, 4, 8$). The performance of the ANN-based approach was evaluated using the mean relative error and standard deviation of relative error, revealing that ANN models accurately predict target response. Moreover, the results showed that the ANN-based approach is almost as accurate as the NLTHA results.

Keywords – Artificial Neural Networks, Machine Learning, Seismic Response Prediction, Nonlinear Time History Analysis, Earthquake Engineering.

I. INTRODUCTION

The seismic response prediction is an important step to estimate the seismic performance of any building and evaluate its behavior when it is subject to earthquake events [1]. Nonlinear time history analysis (NLTHA) is the most reliable technique for determining a building's seismic response to earthquake excitations. It is based on solving the differential equation of motions using mathematical methods, which makes the process complex. In some cases, it takes a long time to perform the analysis.

Many researchers have proposed several alternatives, such as using pushover analysis [2], [3], [4], [5] to calculate the performance point by exploiting the capacity and demand curves. The capacity spectrum method (CSM) and displacement Coefficient method (DCM) are two approaches proposed and adopted by the Applied Technology Council (ATC-40) [6] and the Federal Emergency Management Agency (FEMA-356) [7]. Then, some improvements have been proposed in FEMA-440 [8], and they proposed modifying these approaches. They are replaced by Equivalent linearization (EL) and modified coefficients method (MCM) to improve the performance of the estimation.

On the other hand, artificial intelligence has recently become an exciting approach in many fields, including earthquake engineering. Artificial neural networks are highly used to predict outcomes by training a dataset generated or collected from a selected problem [9], [10], [11], [12], [13], [14], [15], [16], [17].

In this research paper, an Artificial Neural Network (ANN) model is used to estimate the seismic response of a Single Degree of Freedom (SDOF) system by utilizing its characteristics and earthquake parameters. The SDOF represents the equivalent bilinear curve of the pushover curve of a chosen building. A range of SDOF characteristics, including initial stiffness and mass, are selected to generate the dataset. Eighty ground motions are matched using a EUROCODE-8 [18] response spectrum. The SDOF system is then subjected to dynamic excitation, Non-Linear Time-History Analysis (NLTHA) is performed, and the maximum absolute displacement is recorded as an output. The ANN is then trained using a backpropagation algorithm after dividing the dataset into three sections. 80% of the data (80,000 samples) is used to prepare the ANN model, while 10% (10,000 samples) tests the model's performance for each iteration. The remaining 10% is used to validate the model's performance when the training is completed. The ANN's prediction performance is compared to the CSM, DCM, EL, MDM, and NLTHA regarding displacement, mean relative errors, and standard deviation. Nine SDOF systems are selected for this investigation with three vibration periods ($T=0.2$ sec, 0.5 sec, and 1.0 sec) and three lateral strength reduction factors ($R=2, 4, \text{ and } 8$).

II. METHODOLOGY

A. DATASET GENERATING

The dataset comprises 100,000 samples of Single Degree of Freedom (SDOF) systems that have five vibration periods and four elastic stiffness levels, as depicted in Figure 1. These SDOFs will be subjected to 80 ground motions (GM) records matched to a target response spectrum according to EC8. The GMs will be matched to the target response spectrum, as shown in Figure 2.

The dataset will include the following input features: SDOF attributes such as mass (M), elastic stiffness (K), and post-yielding stiffness ratio (α), as well as earthquake parameters like peak ground acceleration, peak ground velocity, peak ground displacement, intensity arias, cumulative energy, spectral acceleration, spectral displacement, cumulative absolute velocity, and central frequency.

The output of the dataset will be the inelastic absolute maximum displacement response of the SDOF.

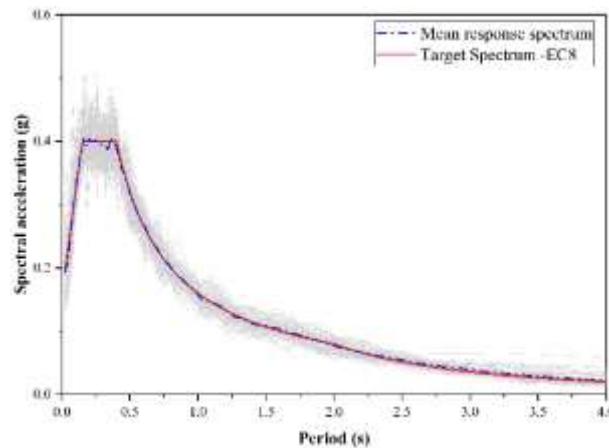

Fig. 1 Ground motions selection and target response spectrum.

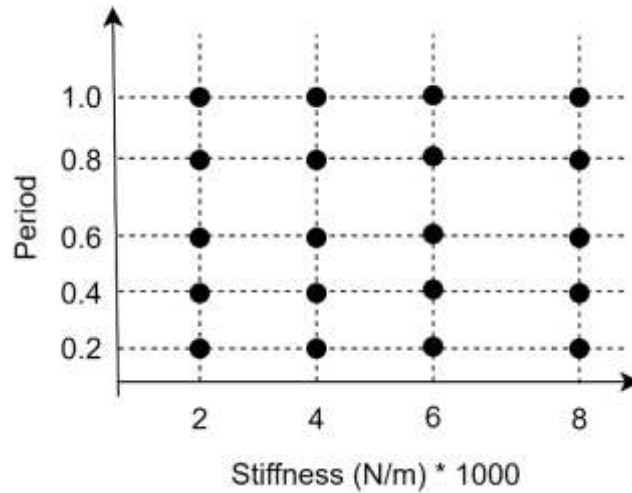

Fig. 2 The selection range of the SDOF characteristic.

B. ARTIFICIAL NEURAL NETWORKS

The ANN is a type of supervised machine learning algorithm that focuses on identifying the relationship between inputs and outputs by determining the optimal weight and biases of the network. The network comprises three layers: the input layer, which has the same number of neurons as the input features; the output layer, which has the same size as the output number; and the hidden layer, which consists of one or more layers depending on the complexity of the problem, as shown in Fig 3.

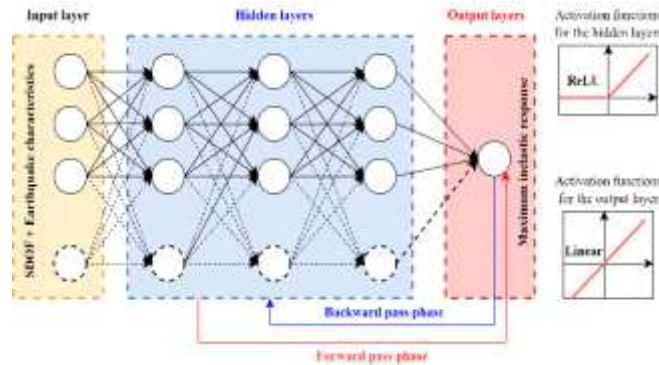

Fig 3 ANN architecture.

The performance of an ANN is primarily influenced by the number of hidden layers, the number of neurons used in the hidden and output layers, and the activation functions used. These hyperparameters play a crucial role in determining the accuracy and effectiveness of an ANN. For this study, the recommended hyperparameters are as follows:

- Number of hidden layers: 4.
- Number of neurons: 40.
- Activation function of hidden layer: ReLU.
- Activation function of output layer: linear.
- Learning rate: 0.01.
- Number of epochs: 500.

Fig 4 illustrates the performance of the ANN in terms of correlation coefficient (R^2) and mean squared error (MSE) in the function of a number of neurons and a number of hidden layers.

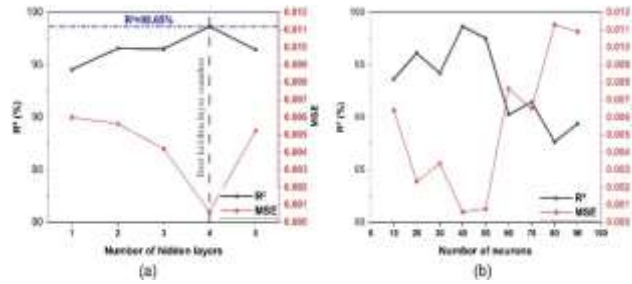

Fig. 4 hyperparameters selection : a/ number of hidden layers, b) number of neurons

III. EXISTING APPROACHES FOR TARGET RESPONSE PREDICTION

Four approaches adopted by ATC-40, FEMA-356, and FEMA-440 are used in this study and presented in the following sections.

A. CAPACITY SPECTRUM METHOD (ATC-40)

The Capacity Spectrum Method (CSM) employs equivalent linearization, wherein the maximum displacement of a Single Degree of Freedom (SDOF) system can be derived from elastic SDOF systems characterized by higher periods and damping ratios compared to the original nonlinear SDOF system. These elevated period and damping ratio values are equivalent periods and equivalent damping ratios.

The CSM procedure is designed to determine a linear or nonlinear system's target displacement or performance point. This method involves several steps to derive the seismic response of the equivalent SDOF system, as shown in Fig 5:

- a- Conversion of the capacity curve: The capacity curve is transformed to characterize the system's ability to withstand seismic forces.
- b- Conversion of the demand curve: The demand curve is transformed to represent the expected seismic input or ground motion.
- c- Identification of the intersection point between the capacity and demand spectra curves: This crucial step determines the system's seismic response and performance level.

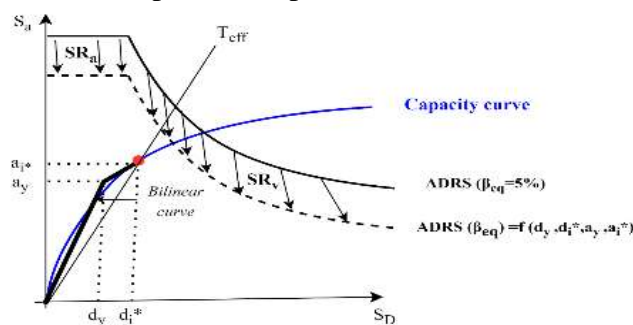

Fig. 5 Bilinear representation and performance point .

B. DISPLACEMENT COEFFICIENT METHOD (FEMA-356)

The Displacement Coefficient Method (DCM) offers a non-iterative numerical approach to estimating displacement demand and target displacement without requiring the conversion of the capacity curve into Acceleration Displacement Response Spectrum (ADRS) representation using equation 1. However, this method is constrained to regular structures where torsional or higher mode effects are absent. In cases where such effects are present, it is recommended to follow specific guidelines to enhance the accuracy of the target displacement estimation.

$$\delta_t = C_0 C_1 C_2 C_3 S_a T_e^2 / 4\pi^2 \quad (1)$$

C_0 = represents a modification factor that links the spectral displacement of the roof.

C_1 = represents a modification factor that correlates the anticipated inelastic response to the elastic response.

C_2 = is a modification factor that incorporates the effect of the hysteresis loop shape on the target inelastic displacement.

C_3 = is a modification factor that accounts for the influence of second-order effects, particularly applicable to structures exhibiting a positive post-yield ratio.

S_a = spectral acceleration at the vibration period T .

T_e = effective period of the equivalent SDOF system.

C. EQUIVALENT LINEARIZATION (FEMA-440)

According to ATC-40 and FEMA-356 guidelines, equivalent linearization involves converting the pushover and demand curves into an Acceleration Displacement Response Spectrum (ADRS) plot. The performance point can be determined graphically or numerically using effective damping and period parameters. However, FEMA-440 introduces a distinct approach. It proposes empirical formulas for calculating the effective period and effective damping. Additionally, a modification factor is introduced to adjust the demand curve, thereby reducing it to estimate the performance point more accurately (see Fig 6).

D. MODIFIED COEFFICIENT METHOD (FEMA-440)

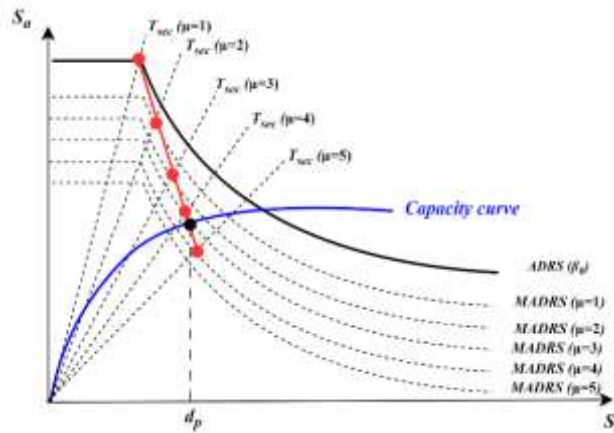

Fig. 6 Procedure C according to FEMA-440 for performance point estimation.

In FEMA-356, a Capacity Design Method (CDM) was introduced and discussed earlier. However, FEMA-440 brings about several enhancements regarding the coefficients utilized. Specifically:

- C_1 is no longer utilized in the newly proposed approach.
- FEMA-440 recommends the use of C_2 , which considers hysteretic behavior.
- C_3 is eliminated, and only strength limits are recommended, streamlining the approach.

IV. COMPARATIVE STUDY

This study compares the ANN results to the NLTHA and four approaches to estimate the performance point. This study aims to check the predictability of the ANN model compared to the existing approaches adopted by ATC and FEMA.

The study uses nine SDOF systems. Three vibration period and three strength reduction factors are selected to perform the comparative study as shown in Fig 7.

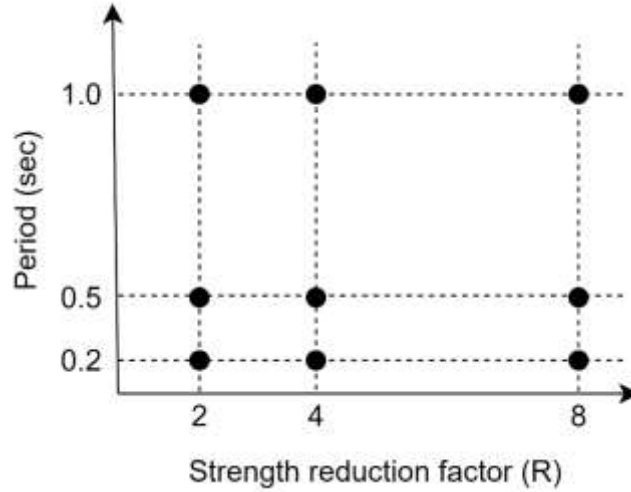

Fig. 7 SDOF characteristics of the case study

The investigation involves comparing the displacement and relative error and their standard deviation (see equations (2) and (3) (4)).

$$E_R = \frac{\delta_{estimated}}{\delta_{NLTHA}} \quad (2)$$

$$\bar{E}_R = \frac{1}{n} \sum_{i=1}^n E_{R,i} \quad (3)$$

$$\sigma_E = \sqrt{\frac{1}{n-1} \sum_{i=1}^n [E_{R,i} - \bar{E}_R]^2} \quad (4)$$

where:

$\delta_{estimated}$ = the estimated response obtained using the proposed approaches.

δ_{NLTHA} = The NLTHA response.

n = number of GMs.

\bar{E}_R = the mean relative error of GMs.

σ_E = the standard deviation of the relative error.

V. RESULTS AND DISCUSSION

The study compares various approaches for estimating the seismic response of SDOF systems, including CSM, EL, and DCM proposed in ATC-40, FEMA-356, and FEMA-440 guidelines. Fig 8 illustrates the mean displacement of the SDOFs compared to the NLTHA, where four approaches and the ANN model are compared to the NLTHA responses. Fig 9 illustrates the mean relative errors of the approaches and the ANN model to the NLTHA responses and the standard deviation of the results. According to the obtained results here are the key findings:

1. Underestimation and Overestimation: The analyzed approaches tend to underestimate seismic response for short vibration periods ($T=0.2$ sec) and overestimate it for longer periods. This discrepancy is observed across strength reduction factors ($R=2, 4,$ and 8).
2. Confidence Intervals: Results from NLTHA analysis indicate that estimated responses fall outside the 16% probability of normal distribution for short periods. For longer periods, confidence intervals of mean plus and minus standard deviation are exceeded by the ATC-40 approach.

3. Analytical Evaluation:

- *CSM-ATC-40*: Underestimates seismic response, particularly for structures with $R=2$, but exhibits low standard deviation, indicating results are close to mean value.
- *EL-FEMA-440*: Shows improvement over previous versions, with better predictability, especially for low values of R . Mean errors tend to underestimate response for short periods and overestimate for $T=1$ sec. Standard deviation increases with period, indicating higher dispersion for longer periods.
- *DCM-FEMA 356 and DCM-440*: Non-iterative methods with similar mean responses and standard deviations. They may underestimate response for short periods and overestimate for longer periods. These are acceptable results for $T=0.2$ and 0.5 seconds but less meaningful for long-period vibrations.
- *ANN model*: the ANN exhibited exceptional predictability for estimating the target response regarding displacement, relative error, and standard deviations. The results showed that the mean response consistently matched the mean response obtained from Nonlinear Time History Analysis (NLTHA) compared to other approaches. Additionally, the relative mean error indicated that the ANN model achieved the best relative error, suggesting results closely resembled those obtained from NLTHA. Moreover, the ANN model demonstrated the lowest standard deviation of relative errors across all ground motions (GMs), indicating high precision in predicting responses compared to NLTHA with minimal prediction dispersion. Overall, the ANN model showcased superior performance in accurately estimating seismic response, highlighting its potential as a practical structural analysis and design tool.

VI. CONCLUSION

In conclusion, the comparative study of various methodologies for estimating seismic response in SDOF systems reveals valuable insights into their strengths and limitations. While traditional approaches such as CSM, EL, and DCM proposed in ATC-40, FEMA-356, and FEMA-440 guidelines offer viable techniques, their performance varies across different vibration periods and strength reduction factors. These methods often tend to underestimate or overestimate seismic response, particularly for shorter or longer periods, respectively. However, advancements in methodologies, as seen in FEMA-440, show improvements in predictability and accuracy, albeit with certain limitations.

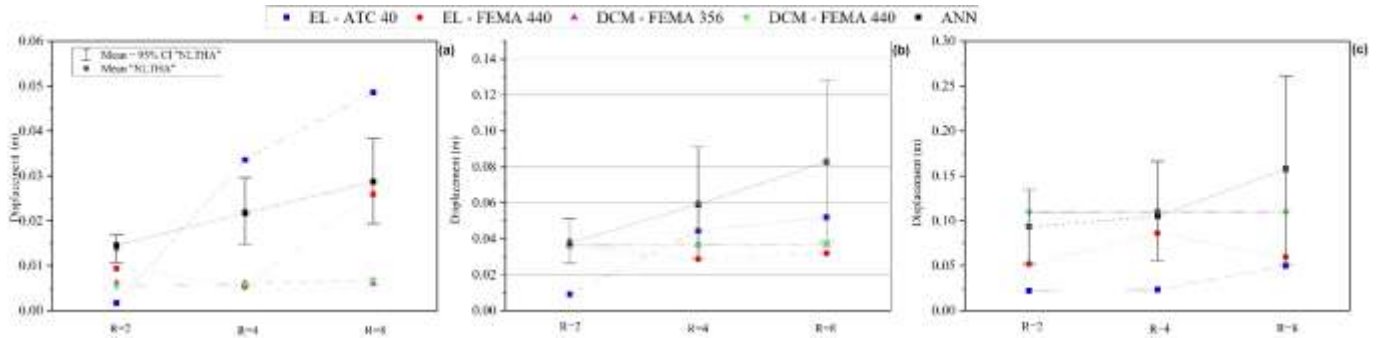

Fig 8 the mean inelastic seismic response of SDOFs : a) for T = 0.2 sec, b) for T = 0.5 sec, and c) for T= 1.0 sec.

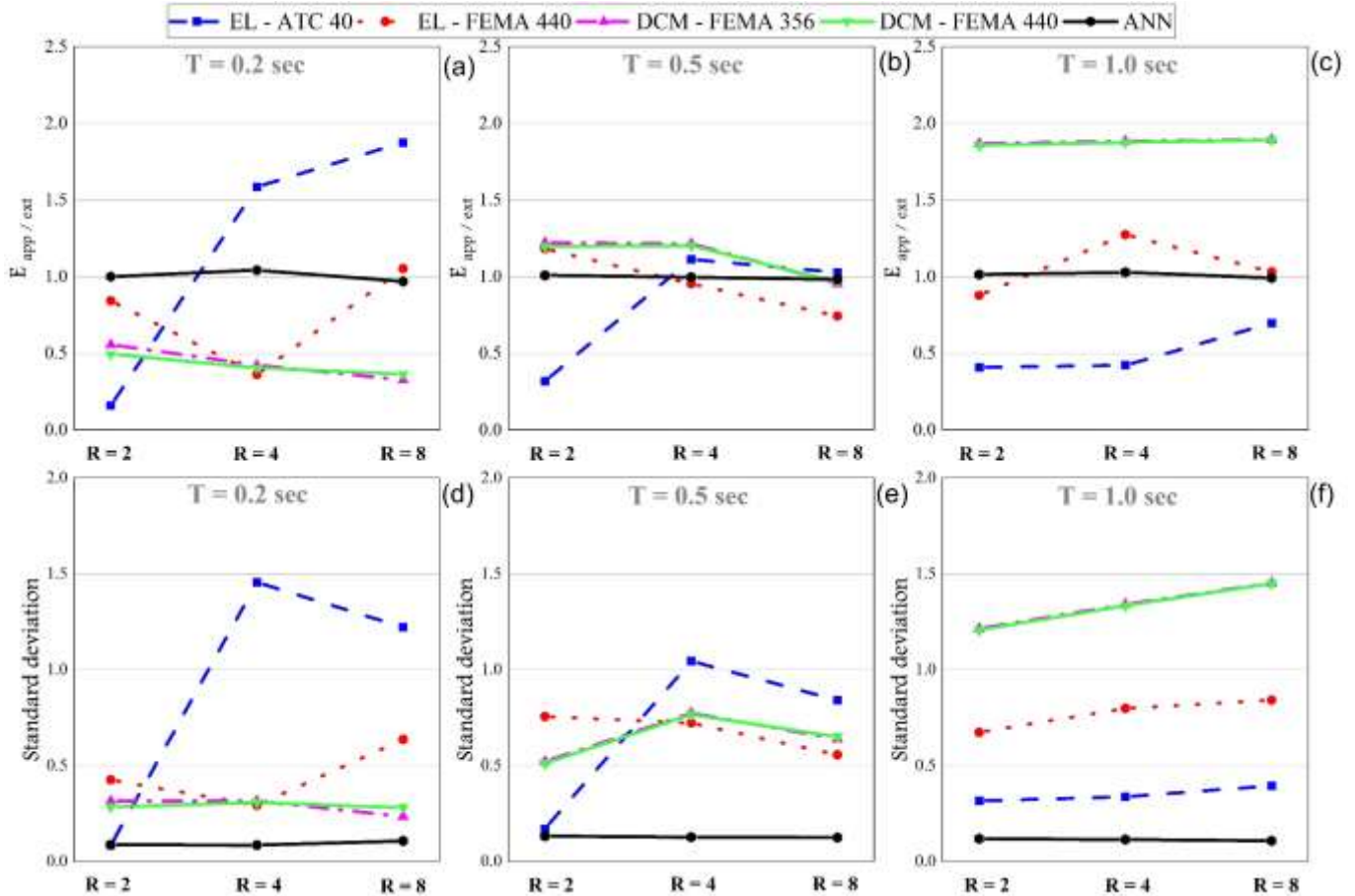

Fig 9 the mean relative error and standard deviation of the comparative study: a) ER,T (T=0.2 sec), b) ER,T (T=0.5 sec), c) ER,T (T=1.0 sec), d) $\sigma_{R,T}$ (T=0.2 sec), e) $\sigma_{R,T}$ (T=0.5 sec), f) $\sigma_{R,T}$ (T=1.0 sec).

Remarkably, using ANN presents a change in basic assumptions in seismic response estimation. The ANN model demonstrates exceptional predictability, closely matching the mean response obtained from NLTHA. Its superior performance is evidenced by the lowest relative error and standard deviation of relative errors across all ground motions, indicating high precision and minimal dispersion in predictions.

The findings underscore the importance of considering a range of methodologies and exploring innovative techniques such as ANN in seismic analysis and design. While traditional approaches offer valuable insights, the emergence of ANN demonstrates promising potential for enhancing the accuracy and reliability of seismic response estimation in structural engineering. Future research should focus on further refining ANN models and integrating them with existing methodologies to optimize seismic design practices and ensure resilient infrastructure in the face of seismic hazards.

References

- [1] G. M. Calvi, R. Pinho, G. Magenes, J. J. Bommer, L. F. Restrepo-Vélez, and H. Crowley, "DEVELOPMENT OF SEISMIC VULNERABILITY ASSESSMENT METHODOLOGIES OVER THE PAST 30 YEARS," 2006.
- [2] W. Abu Jame, "Pushover Analysis of Seismic Performance for Steel Trusses Bridges," May 2023, Accessed: Aug. 14, 2023. [Online]. Available: <http://scholar.ppu.edu:8080/xmlui/handle/123456789/8910>
- [3] A. K. C. et R. K. Goel, "A modal pushover analysis procedure for estimating seismic demands for buildings," *Earthquake engineering & structural dynamics*, vol. 31, pp. 561–582, 2002.
- [4] L. Murdiansyah, R. Permata, and D. Essen, "Modal pushover analysis on reinforced concrete arch bridge to estimate seismic responses," *E3S Web Conf.*, vol. 156, p. 03005, 2020, doi: 10.1051/e3sconf/202015603005.
- [5] "Pushover procedure for seismic analysis of buildings - Tso - 1998 - Progress in Structural Engineering and Materials - Wiley Online Library." Accessed: Jul. 07, 2023. [Online]. Available: <https://onlinelibrary.wiley.com/doi/abs/10.1002/pse.2260010317>
- [6] H. Aabbas and H. Jarallah, "Comparative Study of the Seismic Assessment According to ATC-40, FEMA-356 and FEMA-440 for Existing Hospital Building Located at Baghdad City," *International Journal of Civil Engineering*, vol. 1, May 2021.
- [7] FEMA-356, "Prestandard and Commentary for the Seismic Rehabilitation of Buildings American Society of Civil Engineers." 2000.
- [8] FEMA-440, "Improvement of Nonlinear Static Seismic Analysis Procedures. Federal Emergency Management Agency."
- [9] N. Asgarkhani, F. Kazemi, A. Jakubczyk-Gańczyńska, B. Mohebi, and R. Jankowski, "Seismic response and performance prediction of steel buckling-restrained braced frames using machine-learning methods," *Engineering Applications of Artificial Intelligence*, vol. 128, p. 107388, Feb. 2024, doi: 10.1016/j.engappai.2023.107388.
- [10] P. Hait, A. Sil, and S. Choudhury, "Seismic damage assessment and prediction using artificial neural network of RC building considering irregularities," *Journal of Structural Integrity and Maintenance*, vol. 5, no. 1, pp. 51–69, Jan. 2020, doi: 10.1080/24705314.2019.1692167.
- [11] J. Seo, L. Dueñas-Osorio, J. I. Craig, and B. J. Goodno, "Metamodel-based regional vulnerability estimate of irregular steel moment-frame structures subjected to earthquake events," *Engineering Structures*, vol. 45, pp. 585–597, Dec. 2012, doi: 10.1016/j.engstruct.2012.07.003.
- [12] N. Rahgozar, M. Pouraminian, and N. Rahgozar, "Reliability-based seismic assessment of controlled rocking steel cores," *Journal of Building Engineering*, vol. 44, p. 102623, Dec. 2021, doi: 10.1016/j.job.2021.102623.
- [13] A. A. R. Alilou and M. Pouraminian, "Seismic Fragility Assessment of RC Frame Equipped by Visco-Elastic Dampers Using NLTHA and FNA," *AJEAS*, vol. 12, no. 3, pp. 359–367, Jul. 2019, doi: 10.3844/ajeassp.2019.359.367.
- [14] V. Mahesh, "Artificial neural network (ANN) based investigation on the static behaviour of piezo-magneto-thermo-elastic nanocomposite sandwich plate with CNT agglomeration and porosity," *International Journal of Non-Linear Mechanics*, vol. 153, p. 104406, Jul. 2023, doi: 10.1016/j.ijnonlinmec.2023.104406.
- [15] Y. Liao, R. Lin, R. Zhang, and G. Wu, "Attention-based LSTM (AttLSTM) neural network for Seismic Response Modeling of Bridges," *Computers & Structures*, vol. 275, p. 106915, 2023.
- [16] K. Sajan, A. Bhusal, D. Gautam, and R. Rupakhety, "Earthquake damage and rehabilitation intervention prediction using machine learning," *Engineering Failure Analysis*, vol. 144, p. 106949, 2023.
- [17] N. D. Lagaros and M. Fragiadakis, "Fragility Assessment of Steel Frames Using Neural Networks," *Earthquake Spectra*, vol. 23, no. 4, pp. 735–752, Nov. 2007, doi: 10.1193/1.2798241.
- [18] EC8, "Eurocode 8 - conception et dimensionnement des structures pour leur resistance aux seismes." 2008. Accessed: Oct. 07, 2023. [Online]. Available: <https://www.eurocode1.com/fr/eurocode8.html>



An Application of Sentiment Analysis in Recommender Systems

Leyla Yılmaz¹, Özlem Erdaş Çiçek^{2*}

¹ Computer Engineering Department / Institute of Science, Necmettin Erbakan University, Turkey

² Computer Engineering Department /Necmettin Erbakan University, Turkey

[*ozlem.erdascicek@erbakan.edu.tr](mailto:ozlem.erdascicek@erbakan.edu.tr)

Abstract – The use of e-commerce systems has increased due to advancements in technology and the convenience they offer. The use of e-commerce systems has increased due to advancements in technology and the convenience they offer. The COVID-19 pandemic has further accelerated this trend, with many people relying on e-commerce for their needs. The use of e-commerce systems has increased due to advancements in technology and the convenience they offer. As a result, the number of available products has also increased, making it easier and quicker for users to find what they are looking for. Recommendation systems have become increasingly important in meeting the growing needs of users for personalized products. Their purpose is to identify new products based on users' previous reviews or those of similar users. The new products recommended to the user will be determined by the interactions and comments they make on the products. For this purpose, sentiment analysis methods can be utilized as a valuable tool for enhancing the effectiveness, personalization, and user satisfaction of recommender systems by enabling them to better understand and adapt to the sentiments and preferences of users. In this study, a recommender system was developed by analyzing product comments and associated emotions using the sentiment analysis method. The proposed system utilized the similarity matrix method and pairwise distances method to calculate scoring values. Recommendations were made to other users based on the average score of users, taking advantage of user-user similarity. The evaluation of recommendations was measured using RMSE (root mean squared error) for products rated by the user, rather than making predictions for unrated products.

Keywords – Recommendation Systems, Sentiment Analysis, Similarity Matrix, Pairwise Distance, User Ratings Prediction

I. INTRODUCTION

The use of e-commerce systems has increased with the technology used today and the desire of people to reach their needs more easily. Due to the pandemic, people have taken care of most of their needs through the e-commerce system. Thanks to these developing systems, the number of products has increased. The increase in products has made it easier and faster for users to access the product they want in the e-commerce system. For such reasons, it has become a goal to bring personalized products for users' systems. This goal is therefore to provide a more accurate recommendation system by comparing sentiment analysis methods. In this way, a personalized recommendation system will be created.

We live in a world where recommendations are so pervasive that we forget the apparent ease with which these systems, designed to optimize our consumer preferences, can be incorporated into practically every device and platform. This is why recommendation systems, which are becoming increasingly important, are actually used by many large companies.

The aim of this study is to optimize recommendation systems by using various algorithms used in sentiment analysis to provide a good shopping experience for users. In this case, we will increase the reliability of recommendation systems and prepare a more effective recommendation system for the user.

II. MATERIALS AND METHOD

A. Recommendation Systems

They are algorithms that aim to provide accurate filtering for the user by filtering the user's actions or product content. Recommender systems learn consumers' choices, discover adjustments in the data set and produce results in line with the roadmap on the site (seen in Fig. 1.). Many e-commerce systems such as eBay and Amazon utilize recommendation systems to deliver more efficient results to their customers.



Fig. 1. Recommendation Systems [14]

It should be reminded that recommendation systems are not just algorithms for recommending products. It has started to be used impressively in systems such as data mining and movie recommendation. It creates a learnable recommendation system for the user based on user profiles. Statistical analysis can be done by extracting linear combinations in numerical data with user ratings. Thus, the user may or may not be recommended as determined in the system [1].

B. Types of Recommendation Systems

1) Collaborative Filtering Systems

This filtering method generally works by making an assessment of the user's actions and taking into account the actions of other users. One of its most important advantages is that, unlike content-based filtering systems, it does not need to have any knowledge about the content and therefore can efficiently recommend items that are difficult to perceive. It compares the products previously selected by the users in the system and predicts that the other customer will select similar products. For example, if a user named X prefers P1, P2 and P3 products and a user named Y prefers P2, P3 and P4 products, it is likely that X will prefer P4 and Y will prefer P1 [2].

2) Content-based Filtering Systems

The content-based filtering method focuses on the content of the product and the user's preferred product content. This filtering method focuses on the keywords in the content of the defined product. The algorithm in this system recommends products that the user has previously preferred. The biggest problem with content-based filtering is whether user preferences can be learned from the content source of the products [3]. Comparison of collaborative and content-based filtering can be seen in Fig. 2.

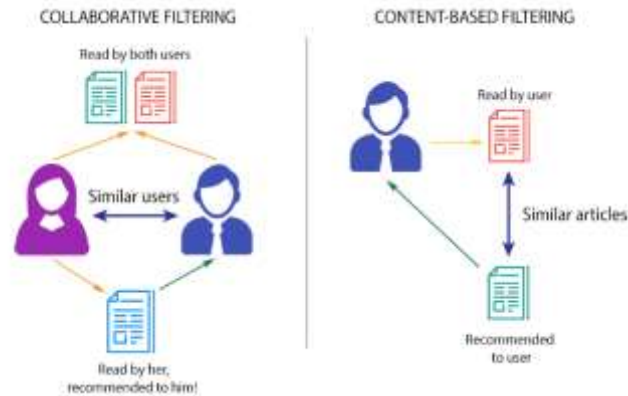

Fig. 2. Collaborative filtering vs. Content-based filtering [15]

3) Hybrid Systems

According to recent research, hybrid recommender systems have emerged to mitigate the disadvantages of collaborative and contextualized systems. Certain research has shown that this system can be more effective. By adding content-based features to a collaborative approach or by adding collaborative features to a content-based recommendation system, these approaches are combined into a single model [3].

Recommendation systems are one of the most important factors that e-commerce systems use when e-commerce users make product choices by generating new suggestions to users for products that have not yet interacted with the interactions of other users using the system. In this study, we developed a new hybrid recommender system that classifies and analyzes the comments on products as positive, negative or neutral with sentiment analysis methods and recommends them to other users accordingly [4].

An important factor is how quickly customers using an e-commerce system can access the product they want to purchase. Recommender systems recommend valuable products to customers by following a path from the actions customers take within the system.

Instead of relying on large-scale customer ratings, recommendation systems can use both ratings (0-10) and reviews (text) to recommend more accurately.

The result of the investigations to create a recommendation system is using a user-user based recommendation algorithm. In order to create this recommendation system, the kaggle dataset was utilized. The data provided to this algorithm is data for user-product rating. Python is used as the programming language. Development is done using Pycharm and Google Colab.

The data read in our data set includes userId, rating and product name. Then, our data is divided into training and test set. A pivot operation is applied to the training dataset with column information as prod_name and row information as userId.

A training set will be used to predict products that are not rated by the user. This training set will only be used for prediction and evaluation on products that are rated by the user. We will need similarities to be defined from user to user. For this, similarity will be created using the cosine metric of the pairwise method.

Instead of using RMSE (root mean squared error) to measure the recommendations made, instead of making predictions for products that have not been rated by the user, the evaluation is made for products that have been rated by the user. By using the user-user algorithm logic, we can prepare a new recommendation system for use in sentiment analysis.

C. Sentiment Analysis

With the increasing use of e-commerce systems, the feedback of users about these systems or the products in the system has started to gain great importance.

Thanks to the feedback of users, e-commerce systems have a great data opportunity. This data is analyzed and aims to determine the actual purpose of the text, the positive, negative or neutral feeling it wants to give for a product [5].

E-commerce systems provide the ability to reuse the data sets created through e-commerce systems and to create healthier systems thanks to this data. In this way, the importance and popularity of sentiment analysis used in systems has increased.

1) *Algorithms for Sentiment Analysis*

There are certain algorithms we can use for sentiment analysis. We can make the comparison with these methods: Linear Svm, Random Forest and XGBoost.

a) *Linear Svm*

It is one of the most widely used and preferred supervised learning methods in classification problems. It relies on maximizing the margin when creating a decision boundary between two classes [5].

b) *Random Forest*

Random forest algorithm is the combination of systems or decision trees that work unrelated to each other and determining the value with the highest, most efficient score among them [7].

c) *XGBoost*

XGBoost (eXtreme Gradient Boosting) is an additional performance version of the Gradient Boosting algorithm. It was introduced by Tianqi Chen and Carlos Guestrin in their 2016 paper "XGBoost: A Scalable Tree Boosting System". One of the most effective features of the algorithm is that it can achieve high predictive power, avoid overlearning, manage empty data, and do it fast. According to Tianqi, XGBoost runs 10 times faster than other popular algorithms [8].

d) *LSTM*

Long Short Term Memory Networks - often referred to as LSTMs - are a special type of RNN that can learn long-term dependencies. They were introduced by Hochreiter and Schmidhuber [9] have been widely cited and popularized by many in the following works. They work tremendously on a wide range of problems and are now widely used. LSTMs are explicitly designed to get ahead of the problem of long-term addiction. Remembering information for long periods of time is practically their default behavior, not something they strive to learn. All recurrent neural networks take the form of a chain of recurrent neural network modules. In standard RNNs, this recurrent module will have a very simple structure, like a single diagnostic layer.

III. RESULTS AND DISCUSSIONS

Today's competitive conditions force companies, especially retail and e-commerce companies, to get to know their customers better, to understand their preferences and behaviors, to predict their needs, and thus to offer them offers that will make them feel special. One of the methods used by companies to meet these personalization needs is product recommendation systems [13].

Recommender systems as a field of data mining and knowledge discovery have an enormous impact on movie recommendation platforms. Appropriate recommendation for viewers considering profiles is a quantifiable argument. Statistical analysis can be done by extracting linear combinations within some numerical data such as user voting actions. Thus, any item such as a movie may or may not be recommended to the user. The numerical calculation of the correlations, i.e. the similarity weighting, should be recalculated before the prediction to increase the impact of user similarities by more constant multiples. This method is called importance weighting, which takes one more step to emphasize the impact of similarities. The closeness between users can be the total number of co-voted items or some other inference for which more complex calculations are performed.

In this study, the importance weighting method related to Pearson Correlation is investigated using comparative approaches. The MovieLens dataset, including both ML100K and ML1M versions, is used in the experiments. The k-fold cross-validation method is applied in a shifted style to increase the number of tests. After obtaining Pearson Correlation Coefficients for user-user similarities, the weights are

expressed using three different approximations. The neighbors are then ranked to select the N closest users for the user under test.

Regarding the experimental results, the explicit method, which uses only the number of items voted in common, is preferred over the other two techniques, taking into account its simplicity and performance. In the experimental plots, accuracy and error measures are presented for the three different importance weighting approaches. Especially for the ML100K dataset, the simple weighting method performs better in terms of error measures [1].

Recommendation systems have been developed to increase user satisfaction and loyalty and to provide users with a personalized system experience. With recommendation systems, users can find the most suitable result for their preferences with the least effort. The importance of personalized recommendation systems has been increasing in recent years and has been applied in various fields such as movies, songs and news. Recommender systems are divided into two categories: memory-based and model-based. Collaborative filtering methods, one of the model-based filtering approaches, are widely used in recommender systems. In this study, jokes in the Jester dataset are clustered with user-based and item-based collaborative filtering methods. The results were compared according to Davies-Bouldin Index, Dunn Index and Silhouette Coefficient values. According to the results of the comparisons, it has been observed that the öget-based collaborative filtering method provides better accuracy than the user-based collaborative filtering method [10].

Companies, especially e-commerce companies, aim to increase customer satisfaction and therefore profitability by using suggestion systems. Today, suggestion systems are widely used and provide strategic advantages to the companies that use them. These systems consist of different stages. In the first stage, a user-product evaluation matrix is used to find similarities between the active user and other users. Then, based on these similarities, the active user's immediate neighbors are identified. In the prediction calculation phase, the weight vector of the active user's immediate neighbors is created using the similarities found in the first step. The neighbors affect the prediction calculation in proportion to these weights. In this study, new methods are developed for the last step of collaborative filtering algorithms, which is the prediction computation step. The performance of these methods is measured with the evaluation metrics used in the literature and compared with the studies in this field [11].

REFERENCES

- [1] Okyay, S., & Aygün, S. (2020). İşbirlikçi Filtreleme için Pearson Korelasyonu Üzerine Statik ve Dinamik Önem Ağırlıklandırma Çarpanları Çalışması. *European Journal of Science and Technology*. <https://doi.org/10.31590/ejosat.822968>
- [2] Yalçın, E. (2021). İşbirlikçi Filtreleme Algoritmalarının Çok-Beğenilen Ürünlere Yönelik Yanlılığı. *Bilecik Şeyh Edebali Üniversitesi Fen Bilimleri Dergisi*. <https://doi.org/10.35193/bseufbd.884634>
- [3] Burke, R. (2002). Hybrid recommender systems: Survey and experiments. *User modeling and user-adapted interaction*, 12, 331-370.
- [4] Aydoğan, M. (2020). Duygu analizi tabanlı yeni bir hibrit tavsiyeci sistem. *Euroasia Journal of Mathematics, Engineering, Natural and Medical Sciences*, 7(13). <https://doi.org/10.38065/euroasiaorg.383>
- [5] Medhat, W., Hassan, A., & Korashy, H. (2014). Sentiment analysis algorithms and applications: A survey. *Ain Shams engineering journal*, 5(4), 1093-1113.
- [6] Suthaharan, S., & Suthaharan, S. (2016). Support vector machine. *Machine learning models and algorithms for big data classification: thinking with examples for effective learning*, 207-235.
- [7] Khanvilkar, G., & Vora, D. (2018). Sentiment analysis for product recommendation using random forest. *International Journal of Engineering & Technology*, 7(3), 87-89.
- [8] Chen, T., & Guestrin, C. (2016). XGBoost: A scalable tree boosting system. *Proceedings of the ACM SIGKDD International Conference on Knowledge Discovery and Data Mining, 13-17-August-2016*. <https://doi.org/10.1145/2939672.2939785>
- [9] Hochreiter, S., & Schmidhuber, J. (1997). Long short-term memory. *Neural computation*, 9(8), 1735-1780.
- [10] Cingiz, M. Ö., & Marangoz, K. (2021). Kullanıcı Tabanlı ve Öğe Tabanlı İşbirlikçi Filtreleme ile Kümeleme Algoritmalarının Değerlendirilmesi. *Avrupa Bilim ve Teknoloji Dergisi*, (28), 453-458.

- [11] Bulut, H., & Milli, M. (2016). New prediction methods for collaborative filtering. *Pamukkale Üniversitesi Mühendislik Bilimleri Dergisi*, 22(2), 123-128.
- [12] Data Set, Available: <https://www.kaggle.com/datasets/datafiniti/grammar-and-online-product-reviews> . [Last visit: 5 December 2023]
- [13] Budak, H., & Gumustas, E. (2022). Kişiselleştirilmiş ürün öneri sistemi için kullanıcı bazlı işbirlikçi filtreleme ve kümeleme kullanan hibrit bir yaklaşım. *İstanbul Ticaret Üniversitesi Sosyal Bilimler Dergisi*, 21(43), 253-268.
- [14] Ferreira, D., Silva, S., Abelha, A., & Machado, J. (2020). Recommendation system using autoencoders. *Applied Sciences*, 10(16), 5510.
- [15] Doshi, S. (2019). Brief on Recommender Systems. Available: <https://towardsdatascience.com/brief-on-recommender-systems-b86a1068a4dd> [Last visit: 5 February 2024]



A Deep Learning-Based Approach for Image Denoising: Harnessing Autoencoders for Removing Gaussian and Salt-Pepper Noises

Halit BAKIR¹, Ufuk DEMİRCİOĞLU^{*2}, Rezan BAKIR¹ and Kemal ADEM¹

¹Computer Engineering, Sivas science and technology university, Turkey

²Mechanical Engineering, Sivas science and technology university, Turkey

**(udemircioglu@sivas.edu.tr) Email of the corresponding author*

Abstract – This research delves into the application of autoencoders as a robust method for noise removal in diverse image datasets, with a primary focus on Gaussian and Slat & Paper (S&P) noise types. Our study systematically evaluates the performance of autoencoder structures in terms of noise removing, utilizing objective metrics such as PSNR, SSIM, MSE, and MAE to quantify their effectiveness. The results conclusively demonstrate the autoencoder's success in minimizing the detrimental impact of noise, particularly excelling in scenarios involving Gaussian and S&P noise. Furthermore, additional analyses reveal the adaptability of the autoencoder in preserving essential image features while effectively suppressing noise artifacts. These compelling findings not only underscore the practical utility of autoencoder-based noise removal methods but also highlight their potential to elevate the reliability of future object detection systems, ensuring more accurate and dependable results in image processing applications.

Keywords – Autoencoder, Image denoising, Gaussian noise, S&P noise

I. INTRODUCTION

Today, the pivotal role of object detection and tracking extends across diverse sectors, including but not limited to autonomous vehicles, security systems, and the healthcare industry. [1], [2]. However, success in this area directly depends on the quality of the input data. The noise contained in data obtained from imaging systems can make object detection and tracking significantly difficult [3]. Noise can be defined as unwanted, random, or systemically added pixels in an image. In object detection and tracking applications, this noise can prevent algorithms from accurately recognizing and tracking objects [4]. Therefore, noise reduction techniques play a critical role in improving the reliability of object detection and tracking systems. Detecting and classifying objects in images is used in almost every aspect of our lives. For this reason, it has become a very active scientific subject, especially after the deep learning revolution and that's why many studies have been conducted in this field [5]. Various innovative architectures, including VGG, ResNet, Inception, Xception, MobileNet, Mask R-CNN, Fast R-CNN, Faster R-CNN, and Multiple object detection and image classification architectures have been proposed and implemented. Remarkably, models like YOLO (You Only Look Once) have demonstrated considerable success in the domain of object detection[6], [7], [8], [9], [10], [11]. While existing literature on object detection and image classification primarily centers on identifying objects within high-quality images [12], it's crucial to acknowledge that real-time images often exhibit noise attributed to environmental factors [12].- Indeed, the removal of undesired noise from images holds significant importance. By eliminating noise, the integrity of the visual data is enhanced, enabling more reliable and accurate object detection and classification processes. Rapid advances in image processing and deep

learning, especially autoencoder-based methods, have attracted significant attention in image denoising. There are a number of studies in the literature where autoencoder structures are used and successful results are obtained, especially in image-denoising applications.

For example, Gondara L. removed noise from the image using an autoencoder. In the [13] study, noise removal methods that are important in medical image analysis were examined. The performances of traditional and deep learning-based algorithms have been evaluated and it has been shown that denoising autoencoders created with small sample sizes can be used effectively. Additionally, it has been shown that noise reduction performance can be improved by increasing the sample size by combining heterogeneous images [13]. Bajaj et al aimed to effectively remove Gaussian noise by using the deep convolutional denoising autoencoder method. The method showed better PSNR performance compared to traditional image-denoising methods. The results obtained show that the proposed model is successful in producing clean images and skip connections are effective in solving the gradient fading problem [14]. Lee et al. in their [15] study used convolutional denoising autoencoder (CDAE) as an effective denoising method in medical image processing, especially in medical images containing microscopic anatomical structures. The proposed image noise removal technique using CDAE exhibits higher performance compared to traditional methods. Tests on chest radiograms obtained from real patients show that the CDAE-based algorithm effectively reduces noise without loss of information [15]. In their study, Nishio et al. proposed a patch-based image denoising method to reduce noise in ultra-low-dose Computed Tomography images. This method, trained using a neural network and a convolutional autoencoder, demonstrated successful performance on pairs of standard-dose and ultra-low-dose Computed Tomography images. Visual evaluations by radiologists and technologists have shown that the proposed method is superior to large-scale non-local mean and block matching and 3D filtering methods [16]. Xiang Q and Pang X studied the statistical properties of restored image residuals produced by Denoising Auto-encoders and proposed an improved training loss function for Denoising Auto-encoders. Additionally, this method was compared with the original Denoising Auto-encoders, BM3D, total variation minimization, and non-local mean algorithms. Experiments show that Improved Denoising Autoencoders introduce fewer non-existent virtual artifacts and are more robust than other leading denoising methods on PSNR and SSIM indices, especially under low SNR [17]. Venkataraman P. studied a neural network model called autoencoder, which is used to perform the task of image denoising. By creating different architectures and comparing the results, the most suitable one for the task was determined. The task of denoising with grayscale images of size 28*28 pixels has been addressed with distinctions between two different architectures: dense autoencoder and convolutional autoencoder. The findings show that convolution layers play a critical role in image noise removal with deep learning [18]. Halit B. and Rezan B. conducted an experimental study to test the durability of the YOLO v5 object detection algorithm in noisy environments. In this context, four different case studies were conducted to evaluate the ability of this algorithm to detect objects in noisy images. Specifically, four datasets were created by injecting different amounts of Gaussian noise into an image dataset with original quality. The YOLO v5 algorithm is trained and tested using the original high-quality dataset. Then, the trained YOLO algorithm was tested using the created noisy image datasets, and the changes in its performance were monitored depending on the injected Gaussian noise ratio. The results obtained showed that the YOLO algorithm could not process noisy images effectively and its performance deteriorated depending on the noise ratio [19].

Motivating on the importance of denoising images this study aims to reveal the potential of the autoencoder to successfully reduce noise in images containing Gauss and S&P noise. Evaluating the autoencoder's ability to effectively reduce such noise could be an important step in achieving more reliable and accurate results in future image processing applications.

Motivation and Innovation:

Noise in image data can negatively affect system performance by affecting the quality of data used for example in object detection and tracking applications. Therefore, noise reduction methods play a critical role in improving the accuracy of systems. Deep learning-based techniques such as Autoencoder can achieve significant success in reducing noise by effectively controlling data representation. These methods aim to create clean, meaningful representations by learning the internal properties of the data set.

This study offers a unique approach that evaluates noise removal methods applications. In particular, it aims to bring a new perspective to the literature by systematically examining the effects of deep learning-based techniques such as autoencoder which could be an important step towards making future systems more reliable and accurate.

II. MATERIALS AND METHOD

Deep learning is a sub-branch of machine learning that can perform complex operations on artificial neural networks and large data sets. Deep learning can model complex data structures and identify relationships between these structures by automatically learning high-level abstractions [20]. Deep learning has been successfully applied in many areas such as image recognition, classification, regression, natural language processing, and voice recognition [21]. Convolutional neural networks (CNN) are deep learning models that are widely used especially in image processing and recognition fields. CNNs learn hierarchically, using convolution and pooling layers to identify patterns and features within data. Thanks to these features, CNNs are successfully used in many tasks such as object detection, face recognition, and image classification [22].

2.1. Autoencoder

Autoencoders are one of the most popular models in the field of Deep Learning [23]. As its name suggests, it aims to automatically learn to convert any data into code. It consists of 2 parts: Encoder and Decoder as shown in Figure 1. These two parts are trained together as if they were a single model during the training phase. After the training is completed, these models are separated and used to compress and decompress the data. For example, if data is to be transported from one place to another, less data can be transported by placing an Encoder on the sender and a Decoder on the receiver. The purpose of the Autoencoder model is to compress the given data and reproduce it with as little loss as possible. Therefore, the loss function of the system is the difference between output and input, which can be expressed as $output - input$ (usually calculated using MSE). The generated code is obtained by taking the output of the middle layer. This layer is called the bottleneck layer and determines the size of the code to be obtained. So, this layer determines how much compression will be done.

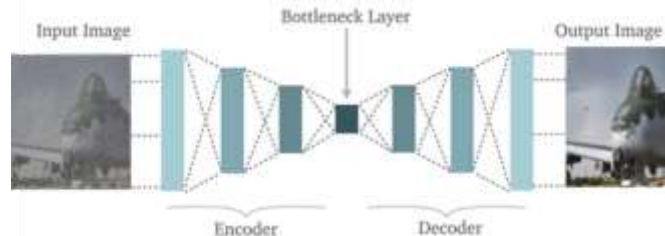

Fig. 1 Schematic of autoencoder

Various metrics are employed to assess the efficacy of noise removal processes including PSNR (Peak Signal-to-Noise Ratio), SSIM (Structural Similarity Index), MSE (Mean Squared Error), and MAE (Mean Absolute Error). PSNR is a metric that measures the similarity between the original and degraded version of a signal. The higher the PSNR value, the less distorted the signal is. SSIM is a metric that evaluates the similarity between two images. Unlike PSNR, SSIM considers pixel values as well as changes such as structure, contrast, and brightness. MSE is a metric that measures the mean square difference between predicted values and actual values. A lower MSE value indicates that the prediction model is closer to the actual data. MAE calculates the mean absolute difference between predicted values and actual values. It is less sensitive to outliers than MSE and provides a simple measure of the model's prediction accuracy. A lower MAE value indicates a closer match between predicted and actual values.

2.2. Gauss Noise

Gaussian noise is a type of noise represented by random numbers with a specific mathematical distribution added to an image. This noise is created using random numbers that usually fit a normal distribution (Gaussian distribution). It can be mathematically represented as follows;

$$PG(z) = \frac{1}{\sigma\sqrt{2\pi}} e^{-\frac{(z-\mu)^2}{2\sigma^2}}$$

Where Z represents the grey level, μ the mean grey value, and σ is the standard deviation.

Gaussian noise is added to the image by changing the values in each pixel by small amounts. These changes are often too small to be noticed by the human eye but can have significant effects on processing and analysis algorithms. Gaussian noise can occur naturally in many environments or can be caused by transmission, sensor errors, or various other factors.

2.3. S&P Noise

Salt and Pepper noise, often abbreviated as S&P noise, is a type of image distortion characterized by the presence of randomly occurring bright and dark pixels, akin to grains of salt and pepper scattered throughout an image [19]. This noise typically occurs due to various factors such as transmission errors in digital communication channels, faults in image sensors, or corruption during image processing. Salt and Pepper noise can significantly degrade image quality and affect the performance of image processing algorithms by introducing erroneous pixels that do not correspond to the true content of the scene. It is commonly mitigated using techniques such as median filtering, which aims to remove the extreme pixel values while preserving the overall structure of the image.

III. EXPERIMENTAL STUDY

All experimental studies have been conducted using a computer with 11th Gen Intel(R) Core(TM) i7-11700 @ 2.50GHz 2.50 GHz, GeForce RTX 3060 12GB GPU, and 64 GB RAM specifications. Some Python libraries such as Tensorflow, Keras, Keras_tuner, NumPy, Sklearn, etc. have been used for constructing the experimental studies in this work.

In this study, an autoencoder model was developed for noise removal. The architecture of the model was designed using a convolutional neural network (CNN) architecture, which is widely used in many deep learning applications. The model summary in Table 1 represents an Autoencoder architecture. The developed model first starts with the input layer. The input layer creates an input tensor for color images with a size of 150x150 pixels and 3 channels. Next comes the encoder part of the model. The encoder part includes convolutional layers (Conv2D), normalization layers (BatchNormalization) and maximum pooling layers (MaxPooling2D). These layers are used to extract features representing the image and reduce its size. After the encoder comes the decoder part of the model. The decoder part includes convolutional layers (Conv2D) and inverses of maximum pooling layers (UpSampling2D) to reconstruct the original input image using the feature vector generated by the encoder. The model is defined as an autoencoder model consisting of input and output layers. Training of the model is performed using the 'Adam' optimization algorithm and the 'mean_squared_error' loss function.

Table 1. Autoencoder Model Layers and Parameters

Layer (type)	Output Shape	Params
input_1 (InputLayer)	(None, 150, 150, 3)	0
conv2d (Conv2D)	(None, 150, 150, 32)	896
batch_normalization	(None, 150, 150, 32)	128
max_pooling2d	(None, 75, 75, 32)	0
conv2d_1 (Conv2D)	(None, 75, 75, 64)	18496
batch_normalization_1	(None, 75, 75, 64)	256
max_pooling2d_1	(None, 38, 38, 64)	0
conv2d_2 (Conv2D)	(None, 38, 38, 64)	36928
batch_normalization_2	(None, 38, 38, 64)	256
up_sampling2d	(None, 76, 76, 64)	0
conv2d_3 (Conv2D)	(None, 76, 76, 32)	18464
batch_normalization_3	(None, 76, 76, 32)	128
up_sampling2d_1	(None, 152, 152, 32)	0
conv2d_4 (Conv2D)	(None, 152, 152, 3)	867
cropping2d	(None, 150, 150, 3)	0

IV. RESULTS & DISCUSSION

Figure 2 shows an example taken from the dataset and includes six different images. The three images in the top row are respectively: (1) Original image, (2) Image with Gaussian noise added, and (3) Image denoised with Autoencoder. The three images in the bottom row are: (1) Original image, (2) Image with S&P noise added, and (3) Image with noise removed by Autoencoder. This figure shows the effectiveness of the autoencoder model for each type of noise and visually demonstrates how successful the model is at cleaning up noisy images. Cleaned images obtained using Autoencoder appear significantly clearer and

less distorted than noisy images. This can be used as an indicator to evaluate the noise removal functionality and efficiency of the model.



Fig. 2 A sample of the dataset used in this study.

Table 2 shows the metric values obtained as a result of Gaussian noise removal. The first column describes the evaluation metrics. The second column shows the values the original images have for each metric. The third column shows the corresponding metric values of images with Gaussian noise added. The fourth column contains the metric values of images denoised using autoencoder. PSNR (Peak Signal-to-Noise Ratio): According to the original image, the PSNR value of the image with Gaussian noise added is 17.56, while the PSNR value of the image with noise removed by autoencoder is 29.86. A higher PSNR value means less signal degradation. SSIM (Structural Similarity Index): According to the original image, the SSIM value of the image with Gaussian noise added is 0.5377, while the SSIM value of the image with autoencoder noise removal is 0.8889. A higher SSIM value indicates structural similarity between two images. MSE (Mean Squared Error): Compared to the original image, the MSE value of the image with Gaussian noise added is 0.0175, while the MSE value of the image with noise removed by autoencoder is 0.0010. A lower MSE value is indicative of a better estimate. MAE (Mean Absolute Error): According to the original image, the MAE value of the image with Gaussian noise added is 0.1128, while the MAE value of the image with noise removed by autoencoder is 0.0211. A lower MAE value is indicative of a better estimate.

Table 2. Result of Gaussian denoised image

Evaluation Metric	Original	Gaussian Noise	Denoised
PSNR	inf	17.56	29.86
SSIM	1.0	0.5377	0.8889
MSE	0.0	0.0175	0.0010
MAE	0.0	0.1128	0.0211

Table 3 contains the metric values obtained after S&P noise removal. The first column indicates the evaluation metrics. The second column presents the reference values for each metric of the original images. The third column shows the corresponding metric values of images with S&P noise added. The fourth column contains the metric values of images denoised using an autoencoder. Compared to the original image, the PSNR value of the image with S&P noise added is 7.67, while the PSNR value of the image with autoencoder noise removal is 30.64. A higher PSNR value means less signal degradation. Compared to the original image, the SSIM value of the image with S&P noise added is 0.2838, while the SSIM value of the image with noise removed by autoencoder is 0.9151. A higher SSIM value indicates

structural similarity between two images. Compared to the original image, the MSE value of the image with S&P noise added is 0.1712, while the MSE value of the image with noise removed by the autoencoder is 0.0009. A lower MSE value is indicative of a better estimate. Compared to the original image, the MAE value of the image with S&P noise added is 0.3834, while the MAE value of the image with autoencoder noise removal is 0.0208. A lower MAE value is indicative of a better estimate.

Table 3. Result of S&P denoised image

Evaluation Metric	Original	S&P Noise	Denoised
PSNR	inf	7.67	30.64
SSIM	1.0	0.2838	0.9151
MSE	0.0	0.1712	0.0009
MAE	0.0	0.3834	0.0208

V. CONCLUSION

As a result, this study shows that the autoencoder-based noise removal method can successfully combat especially Gaussian and S&P-type noise. The evaluations reveal that the noise reduction performance of the proposed method is quite impressive, based on PSNR, SSIM, MSE, and MAE metrics. The results of this study show that autoencoder-based noise removal methods are successfully applied, and noisy images are effectively cleaned. These results emphasize the potential of autoencoders for noise reduction in object detection and tracking applications. Notably, while existing literature predominantly focuses on a singular type of noise, our future work aims to address the denoising challenges presented by images containing multiple types of noise, commonly encountered in diverse scenarios. This strategic direction is crucial for effectively handling complex real-world applications. Understanding the intricate interactions between different types of noise and implementing adept removal strategies represents a pivotal opportunity for future innovation in the field of image processing. In this context, our forthcoming efforts will involve evaluating the performance of deep learning-based methods on an extensive dataset featuring diverse noise types. Our primary focus is on developing a more comprehensive and universal denoising solution to enhance the adaptability and efficacy of noise removal techniques across a wide array of practical scenarios.

ACKNOWLEDGMENT

This work has been supported by the Scientific Research Projects Coordination Unit of the Sivas University of Science and Technology. Project Number: 2023-GENL-Müh-0007.

REFERENCES

- [1] Y. Xiao et al., "A review of object detection based on deep learning," *Multimed Tools Appl*, vol. 79, no. 33–34, pp. 23729–23791, Sep. 2020, doi: 10.1007/s11042-020-08976-6.
- [2] Z. Q. Zhao, P. Zheng, S. T. Xu, and X. Wu, "Object Detection with Deep Learning: A Review," *IEEE Transactions on Neural Networks and Learning Systems*, vol. 30, no. 11. Institute of Electrical and Electronics Engineers Inc., pp. 3212–3232, Nov. 01, 2019. doi: 10.1109/TNNLS.2018.2876865.
- [3] L. Fan, F. Zhang, H. Fan, and C. Zhang, "Brief review of image denoising techniques," *Visual Computing for Industry, Biomedicine, and Art*, vol. 2, no. 1. Springer Science and Business Media B.V., Dec. 01, 2019. doi: 10.1186/s42492-019-0016-7.
- [4] C. Tian, L. Fei, W. Zheng, Y. Xu, W. Zuo, and C. W. Lin, "Deep learning on image denoising: An overview," *Neural Networks*, vol. 131. Elsevier Ltd, pp. 251–275, Nov. 01, 2020. doi: 10.1016/j.neunet.2020.07.025.

- [5] A. E. Ilesanmi and T. O. Ilesanmi, "Methods for image denoising using convolutional neural network: a review," *Complex and Intelligent Systems*, vol. 7, no. 5, pp. 2179–2198, Oct. 2021, doi: 10.1007/s40747-021-00428-4.
- [6] K. He, G. Gkioxari, P. Dollar, and R. Girshick, "Mask R-CNN," in *Proceedings of the IEEE International Conference on Computer Vision*, Institute of Electrical and Electronics Engineers Inc., Dec. 2017, pp. 2980–2988. doi: 10.1109/ICCV.2017.322.
- [7] A. G. Howard et al., "MobileNets: Efficient Convolutional Neural Networks for Mobile Vision Applications," Apr. 2017, [Online]. Available: <http://arxiv.org/abs/1704.04861>
- [8] R. Girshick, "Fast R-CNN," in *2015 IEEE International Conference on Computer Vision (ICCV)*, IEEE, Dec. 2015, pp. 1440–1448. doi: 10.1109/ICCV.2015.169.
- [9] J. Redmon, S. Divvala, R. Girshick, and A. Farhadi, "You Only Look Once: Unified, Real-Time Object Detection." [Online]. Available: <http://pjreddie.com/yolo/>
- [10] K. He, X. Zhang, S. Ren, and J. Sun, "Deep Residual Learning for Image Recognition." [Online]. Available: <http://image-net.org/challenges/LSVRC/2015/>
- [11] F. Chollet, "Xception: Deep learning with depthwise separable convolutions," in *Proceedings of the IEEE conference on computer vision and pattern recognition*, 2017, pp. 1251–1258.
- [12] H. BAKIR and S. B. EKER, "An Experimental Study for Evaluating the Performance of CNN Pre-Trained Models in Noisy Environments," *Politeknik Dergisi*, vol. 27, no. 1, pp. 355–369, doi: 10.2339/politeknik.1162469.
- [13] L. Gondara, "Medical image denoising using convolutional denoising autoencoders," in *2016 IEEE 16th international conference on data mining workshops (ICDMW)*, IEEE, 2016, pp. 241–246.
- [14] K. Bajaj, D. K. Singh, and M. A. Ansari, "Autoencoders Based Deep Learner for Image Denoising," in *Procedia Computer Science*, Elsevier B.V., 2020, pp. 1535–1541. doi: 10.1016/j.procs.2020.04.164.
- [15] D. Lee, S. Choi, and H. J. Kim, "Performance evaluation of image denoising developed using convolutional denoising autoencoders in chest radiography," *Nucl Instrum Methods Phys Res A*, vol. 884, pp. 97–104, Mar. 2018, doi: 10.1016/j.nima.2017.12.050.
- [16] M. Nishio et al., "Convolutional auto-encoder for image denoising of ultra-low-dose CT," *Heliyon*, vol. 3, p. 393, 2017, doi: 10.1016/j.heliyon.2017.
- [17] Q. Xiang and X. Pang, "Improved Denoising Auto-encoders for Image Denoising, Proceedings, 2018 11th International Congress on Image and Signal Processing, BioMedical Engineering and Informatics : CISP-BMEI 2018 : 13-15 October 2018, Beijing, China," 2018.
- [18] P. Venkataraman, "Image Denoising Using Convolutional Autoencoder," arXiv preprint arXiv:2207.11771, 2022.
- [19] H. BAKIR and R. BAKIR, "evaluating the robustness of yolo object detection algorithm in terms of detecting objects in noisy environment," *Journal of Scientific Reports-A*, no. 054, pp. 1–25, 2023, doi: 10.59313/jsr-a.1257361.
- [20] U. Demircioğlu and H. Bakır, "Deep learning-based prediction of delamination growth in composite structures: bayesian optimization and hyperparameter refinement," *Phys Scr*, vol. 98, no. 10, Oct. 2023, doi: 10.1088/1402-4896/acf812.
- [21] U. Demircioğlu, A. Sayil, and H. Bakır, "Detecting Cutout Shape and Predicting Its Location in Sandwich Structures Using Free Vibration Analysis and Tuned Machine-Learning Algorithms," *Arab J Sci Eng*, vol. 49, no. 2, pp. 1611–1624, Feb. 2024, doi: 10.1007/s13369-023-07917-3.
- [22] H. BAKIR, S. OKTAY, and E. TABARU, "detection of pneumonia from x-ray images using deep learning techniques," *Journal of Scientific Reports-A*, no. 052, pp. 419–440, 2023, doi: 10.59313/jsr-a.1219363.
- [23] H. Bakır and R. Bakır, "DroidEncoder: Malware detection using auto-encoder based feature extractor and machine learning algorithms," *Computers and Electrical Engineering*, vol. 110, Sep. 2023, doi: 10.1016/j.compeleceng.2023.108804.



Efficient Swin Transformer Model for Accurate Detection of Lung Cancer

Ishak Pacal*

¹Department of Computer Engineering /Faculty of Engineering, Iğdir University, Iğdir, Turkey

**(ishak.pacal@igdir.edu.tr) Email of the corresponding author*

Abstract – Lung cancer poses a challenging global health issue, necessitating early diagnosis to enhance treatment effectiveness and patient prognosis. This study investigates the utilization of deep learning methodologies, with a specific focus on the Swin Transformer architecture, to automate the detection of lung cancer from computed tomography (CT) scans. Utilizing a publicly available dataset, the study extensively trains and evaluates various convolutional neural network (CNN) architectures and other image transformer models. We propose a Swin-based model for more effective detection of lung cancer from CT images. The proposed model, optimized by adjusting the depth in the Swin-Base model and reducing the window size to 6 to focus more on cancerous tissues, achieves more effective detection. Alongside the proposed model, other deep learning models are optimized using data augmentation and transfer learning techniques. The findings highlight the superior performance of the proposed Swin model, reaching an impressive accuracy rate of 97.58% and a well-balanced F1 score of 95.42%. Furthermore, the research underscores the transformative potential of attention-based models in medical image analysis, offering effective pathways to advance lung cancer diagnosis and ultimately improve patient care outcomes.

Keywords – Swin Transformer, Lung Cancer Detection, Deep Learning, Cnns, Medical Image Analysis

I. INTRODUCTION

Cancer is a challenging illness that causes millions of deaths worldwide, particularly with types like lung cancer that are difficult to treat [1]. Lung cancer stands as a primary cause of cancer-related deaths and encompasses numerous clinically significant subtypes [2]. This disease is heterogeneous, and among its determinants, the histological phenotype holds particular importance in terms of treatment response and overall clinical outcomes [3]. While lung cancer has a high chance of successful treatment when detected early, late diagnosis can lead to serious health issues [4]. Therefore, early diagnosis, as with many cancer types, holds critical importance in combating cancer. Traditional medical imaging techniques have long been a cornerstone in diagnosing lung cancer [5]. Among these, PET, CT, and MRI stand as the principal modalities utilized in medical investigations [5,6]. Specifically, Computerized Tomography (CT) plays a pivotal role by delivering intricate details of lung tissue, enabling the detection of even minute tumors [7]. The provision of such high-resolution images is crucial for identifying cancer at its early stages, significantly enhancing the efficacy of treatment options [8].

Detecting cancer from lung images is prone to false positives and true negatives, leading to additional investigations, costs, and stress for patients, and an increased burden for doctors [6]. Recently, the involvement of Computer-Aided Diagnosis (CAD) systems in lung cancer detection has shown significant success, achieving greater accuracy than humans in a timely manner [4,9–11]. In this context, Artificial Intelligence and deep learning technologies can accelerate and improve the diagnostic process for physicians by analyzing medical images and learning complex patterns, aiding in the more accurate detection of early-stage lung cancer cases [12–15]. Convolutional Neural Networks (CNN) and Vision Transformers (ViT) have significantly impacted the widespread adoption of deep learning algorithms in

diverse areas such as agriculture, defense, natural language processing, generative AI, autonomous driving, and medical image processing [16–19]. These technological advances have set new benchmarks in image recognition and classification, particularly in medical imaging for tasks like lung cancer classification, detection, and segmentation. CNNs excel in capturing local features, while ViTs provide a broader context analysis, addressing some limitations of CNNs. Both architectures are crucial in developing and applying deep learning models for lung cancer diagnosis, thereby enhancing and streamlining diagnostic processes.

The robustness of deep learning in swiftly and accurately diagnosing lung cancers has drawn numerous researchers to this field, leading to significant advancements. For instance, Raza et al. [4] proposed a novel predictive model, Lung-EffNet, based on transfer learning to detect lung cancer. Lung-EffNet is constructed using the foundation of the EfficientNet architecture and further customized by incorporating supplementary layers. Experimental findings demonstrate Lung-EffNet's ability to effectively diagnose lung cancer patients into categories. Marentakis et al. [20] employed deep learning methods for detecting of lung cancer that included various techniques, including analyzing image features and using different types of neural networks, alone and in combination. They also had expert radiologists evaluate the CT images independently.

Shakeel et al. [11] introduced an innovative approach for lung cancer prediction utilizing advanced image processing and machine learning techniques. Their methodology involves gathering CT scan images of non-small cell lung cancer and enhancing them using a multilevel brightness preservation method. Subsequently, an upgraded deep neural network is employed to identify affected regions and extract features. Chaunzwa et al. [21] proposed a method using CT scans to predict the histology of non-small cell lung cancer tumors. They utilized CNNs trained on data from 311 early-stage NSCLC patients at Massachusetts General Hospital. Their CNNs successfully predicted tumor histology with an AUC of 0.71. Sori et al. [22] introduced a novel approach termed "denoising first," utilizing a two-path convolutional neural network (DFD-Net) to tackle the complexities of lung cancer detection. The methodology involved denoising through a residual learning denoising model (DR-Net), followed by detection using a two-path convolutional neural network. These paths aimed to integrate local and global features, with each employing distinct receptive field sizes to effectively capture local and global dependencies. Pandit et al. [8] significantly improved the accuracy of lung cancer prediction while simultaneously reducing processing time by incorporating multi space images into the pooling layer of a CNN. They introduced an autoencoder system to enhance accuracy, preprocess CT images, and reconstruct them for more effective prediction purposes.

II. MATERIALS AND METHOD

In this section, details of the CT dataset used for lung cancer detection are provided along with the proposed Swin Transformer architecture.

A. Deep Learning

The advent of deep learning has brought about a paradigm shift in artificial intelligence, revolutionizing the way algorithms learn from extensive datasets, particularly in the domain of computer vision [23]. Central to this transformation are CNNs, which have emerged as powerful tools for extracting intricate features from images through interconnected layers, thereby attaining profound insights into visual content [23]. However, the recent introduction of vision transformer models signifies a significant leap forward in this field. These models depart from the traditional CNN architecture by leveraging self-attention mechanisms and positional embeddings instead of convolutional layers. By integrating both local and global information, vision transformers offer a comprehensive approach to understanding visual scenes, presenting a compelling alternative to CNNs in various applications within the realm of computer vision [24,25].

B. Proposed Swin Transformer

Introduced by Microsoft Research in 2021, the Swin Transformer represents a monumental leap forward in the realm of computer vision [26]. This cutting-edge model introduces groundbreaking

concepts, including hierarchical feature maps and shifted window attention, engineered to tackle the complexities of processing large-scale image datasets with unparalleled efficiency and effectiveness. At its core, the Swin Transformer boasts an intricate architecture comprised of four meticulously designed stages, each meticulously optimized to enhance the processing of input images. The structure of the proposed Swin Transformer is depicted in Fig. 1.

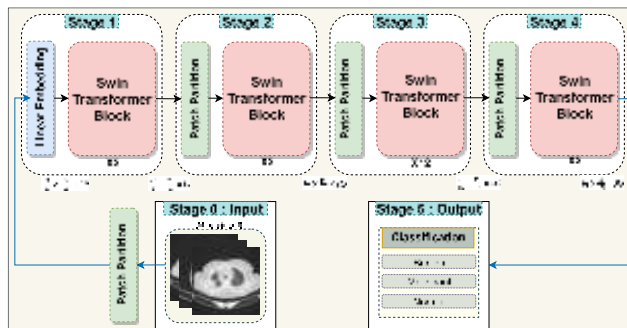

Fig. 1 Proposed Swin Transformer model

Each stage of the Swin Transformer contributes significantly to the model's functionality and effectiveness. These stages are strategically designed to progressively refine the features extracted from the input data, forming a hierarchical representation that captures both local and global information adeptly.

In the realm of lung cancer detection, the initial stage is pivotal for extracting foundational features from the input CT images. This involves dividing the image into smaller patches and processing them through the early layers of the Swin Transformer to extract basic patterns and features essential for subsequent analysis.

Subsequently, the second stage builds upon these extracted features, delving deeper to capture more nuanced information about the image content. This stage employs deeper layers of the Swin Transformer to extract complex features and patterns relevant to lung cancer detection.

Finally, the third stage consolidates the extracted features, preparing them for the final classification or prediction task. Here, additional processing is conducted to integrate features from different regions of the image, ensuring a comprehensive representation that facilitates accurate discrimination between benign, malignant, and normal lung tissue.

Given the critical role of each stage, specific adjustments were made to the third stage of our Swin Transformer model for lung cancer detection. By reducing the number of layers from 18 to 12, we aimed to enhance the model's performance while considering the unique characteristics of our CT-based dataset. This modification results in a more streamlined architecture, balancing model complexity and computational efficiency to improve the model's accuracy in detecting lung cancer lesions while conserving computational resources.

In our implementation using CT data for lung cancer detection with the Swin Transformer, we encountered instances where tumors appeared relatively small in size. To address this, we adjusted the window size from 7 to 6, aiming to enhance the model's ability to detect smaller tumors more effectively. This modification was made in response to the specific characteristics of the CT data and aimed to improve the sensitivity of the Swin Transformer in identifying smaller lesions associated with lung cancer. Adjusting the window size to 6 allowed for finer-grained analysis of the image data, potentially leading to more accurate detection and diagnosis of tumors within the lung tissue.

Initially, input images undergo a meticulous segmentation process, wherein they are divided into patches before being meticulously processed through Transformer blocks. This segmentation allows for a detailed examination of the CT data, facilitating the effective diagnosis of lung cancer. Subsequently, these processed patches are seamlessly merged to construct hierarchical feature representations, a pivotal aspect of the Swin Transformer's architectural framework. These hierarchical features enable the model to capture both local and global information crucial for accurate diagnosis. A cornerstone of this architecture

lies in the Swin Transformer Blocks (STBs), which serve as the backbone of its functionality, as depicted in Fig. 2.

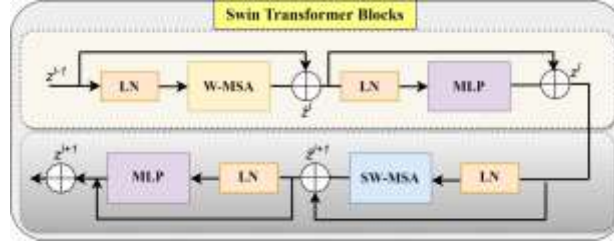

Fig. 2 General structure of Swin Transformer blocks

These blocks incorporate advanced multi-head self-attention mechanisms, including window-based and shifted window-based attention, enabling the model to efficiently capture relevant features indicative of lung cancer pathology. This comprehensive approach ensures the Swin Transformer's effectiveness in diagnosing lung cancer from CT data, offering insights into the presence and characteristics of cancerous lesions with high precision and reliability. The Swin Transformer incorporates two types of multi-head self-attention (MSA) modules: window-based MSA (W-MSA) and shifted window-based MSA (SW-MSA). These modules play a crucial role in capturing the connections among various elements in the input data, enabling the model to prioritize pertinent information and improve its comprehension of contextual associations.

$$\Omega (\text{MSA}) = 4hwC^2 + 2(hw)^2C \quad (1)$$

$$\Omega (\text{W-MSA}) = 4hwC^2 + 2M^2hwC \quad (2)$$

In Equation 1 and Equation 2, the MSA exhibits a quadratic computational complexity relative to the number of tokens, while the W-MSA module transitions to a linear complexity when M is constant (with a default value of 7). This arrangement notably enhances the Swin Transformer's performance and efficiency compared to the standard Transformer model.

Table 1. Details of Proposed Swin vs Swin Transformer

RTX 3090 Batch-size:16	Swin-Base	Proposed Swin
Params	86.75 M	67.81 M
GPU usage	6103 MB (25%)	5103 MB (21%)
Depths	(2, 2, 18, 2)	(2, 2, 12, 2)
Window-size	7	6

C. Dataset

The publicly available dataset known as IQ-OTH/NCCD [27,28] was utilized for the diagnosis of lung cancer and can be accessed through Kaggle [29] and Mendeley data [30]. CT scans from patients who are either healthy or have been diagnosed with lung cancer at various stages are included in this dataset. Numerous radiologists and oncologists have annotated it. The dataset is made up of CT scans of the human chest from 110 different instances, each with a different age, gender, level of education, place of residence, and way of life. As seen in Fig. 3, the cases in this study were split into three categories: benign, malignant, and normal.

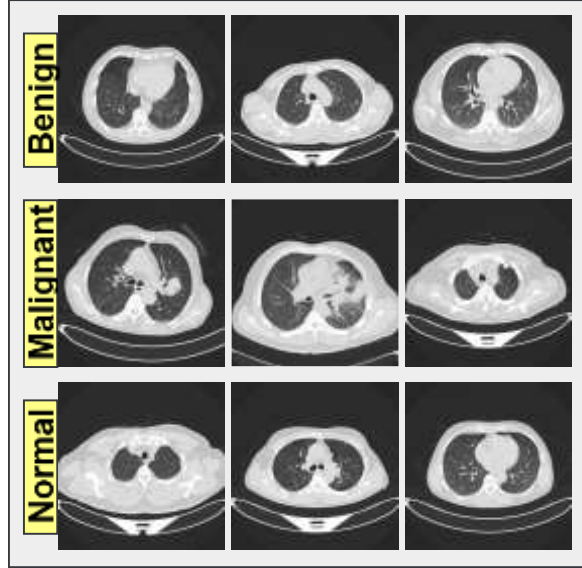

Fig. 3 Sample images from the IQ-OTH/NCCD dataset

Out of the 110 instances examined, 40 were found to be malignant, 15 to be benign, and 55 to be normal. The IQ-OTH/NCCD dataset comprises a total of 1097 images, with 120 images belonging to the benign class, 561 images to the malignant class, and 416 images to the normal class.

D. Implementation and Training Details

In this study, models were trained and tested using NVIDIA RTX 3090, the PyTorch framework, and the Python programming language. The publicly available IQ-OTH/NCCD CT dataset was split into 70% training, 15% validation, and 15% test data, with models evaluated solely on unseen test data. Data augmentation techniques were employed to enhance the models' generalization ability, involving various transformations to generate new examples and reduce overfitting. Specifically, cropping, flipping, rotating, copying-pasting, cropping, and scaling were applied to expand the dataset. Additionally, transfer learning with pre-trained ImageNet weights was utilized for faster model training and improved performance. As a result, the combination of data augmentation and transfer learning techniques enhanced the models' generalization ability and facilitated an effective training and testing process.

E. Performance Metrics

Performance metrics are crucial for evaluating the effectiveness and generalizability of deep learning algorithms. They help assess models during training and on validation and test datasets. Key metrics include accuracy, precision, recall, and F1 score, which quantify different aspects of model performance such as overall correctness, ability to identify true positives, and balance between precision and recall. These metrics are calculated using formulas involving true positives (TP), true negatives (TN), false positives (FP), and false negatives (FN).

$$Accuracy = (TP+TN)/(TP+TN+FP+FN)$$

$$Precision = (TP)/(TP+FP)$$

$$Recall = (TP)/(TP+FN)$$

$$F1-score = 2x (Precision x Recall)/(Precision+ Recall)$$

III. RESULTS

In this study, the proposed Swin Model's actual performance was measured and compared by training base models of popular CNN models including ResNet50, DenseNet121, Xception, as well as popular vision transformer architectures such as ViT, DeiT, and Swin, on the IQ-OTH/NCCD CT dataset under the same conditions. The results of the experiment are shown in Table 3, displaying the performance

metrics of these models. The evaluation of the models trained on the IQ-OTH/NCCD CT dataset was conducted using common performance metrics such as accuracy, precision, recall, and F1 score.

Table 2. Experimental results of deep learning models

Model	Accuracy	Precision	Recall	F1
ResNet50 [31]	0.9636	0.9286	0.9286	0.9286
DenseNet121 [32]	0.9636	0.9224	0.9418	0.9312
Xception [33]	0.9636	0.9378	0.9153	0.9256
Swin-Base [26]	0.9697	0.9452	0.9339	0.9393
ViT-Base-16 [34]	0.9636	0.9224	0.9418	0.9312
DeiT-Base [35]	0.9697	0.9452	0.9339	0.9393
Proposed	0.9758	0.9445	0.9656	0.9542

As seen in Table 2, a detailed comparison based on the diagnosis of lung cancer was conducted among deep learning models trained on the IQ-OTH/NCCD CT dataset. While the proposed model achieves the highest accuracy rate (97.58%), DeiT-Base demonstrates the best performance in terms of precision (94.52%). Additionally, the proposed model also holds the highest F1 score (95.42%), indicating a successful balance between precision and recall rates. On the other hand, although Xception model attains the highest accuracy rate with 93.78% precision, it exhibits slightly lower performance in recall rate (91.53%). However, Swin-Base and DeiT-Base models showcase similar performances with 96.97% accuracy rate and 93.39% recall rate, while Swin-Base model slightly surpasses DeiT-Base in precision with 94.52%. In conclusion, the superior accuracy, precision, and F1 scores of the proposed model emphasize its effectiveness and performance in image classification tasks, particularly in the diagnosis of lung cancer. These results indicate that attention-based image transformers may perform comparably or even better than traditional CNN architectures, such as ResNet50, DenseNet121, and Xception. The proposed model holds potential significance in the effective diagnosis of lung cancer, potentially playing a critical role in the early detection and treatment of the disease.

IV. DISCUSSION

The optimization performed on the proposed Swin model by reducing the window size from 7 to 6 and decreasing the stage 3 count (depth) from 18 to 12 has resulted in a reduction in both GPU usage and parameter count during the training process. As a consequence of these modifications, the training process has been completed more rapidly, and a significant improvement in the model's performance has been achieved. This approach has allowed the model to learn more effective features, leading to higher accuracy in diagnosing lung cancer. Ultimately, the optimized Swin model has taken a significant step forward by increasing training efficiency and achieving more successful results in lung cancer diagnosis.

These findings underscore the potential of attention-based image transformers highlighted by the proposed model, offering a new perspective in medical image analysis. Outperforming other models, the proposed model successfully distinguishes between cancerous and non-cancerous lung tissues. Moreover, the performance parity of attention-based models like Swin-Base and DeiT-Base with traditional CNN architectures emphasizes the importance of attention-based approaches in medical image analysis. These results hold promise for achieving more accurate and effective results in the diagnosis and treatment of

lung cancer. A confusion matrix for the proposed model is provided in Fig. 4.

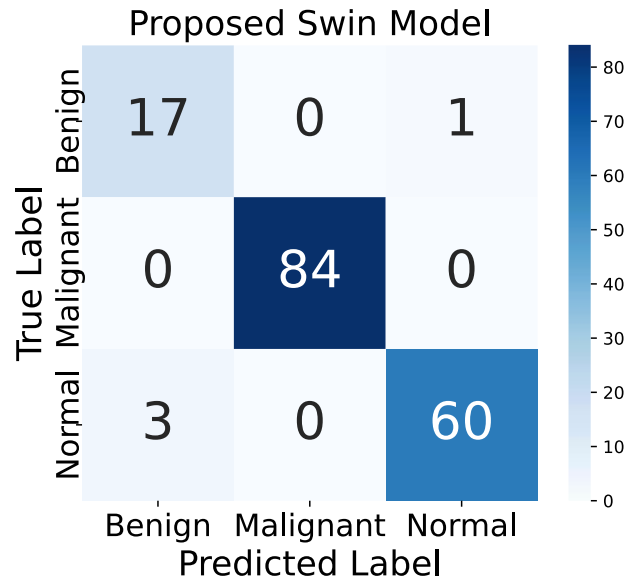

Fig. 4 Confusion matrix of proposed Swin model

As seen in Fig. 4, the proposed model accurately identifies the Malignant class, with 84 TP predictions, while in the Benign class, there are 17 TP, 3 FP, and 1 FN. In the Normal class, there are 60 TP, 3 FN, and 1 FP. Particularly in the cancerous class, the proposed model achieves a high level of accuracy, correctly identifying all predictions, resulting in a notable potential for success in lung cancer diagnosis, with an overall accuracy of 97.58%.

V. CONCLUSION

This study emphasizes the importance of deep learning methodologies, particularly the Swin Transformer architecture, in automating the detection of lung cancer from computed tomography (CT) scans. Through comprehensive training and evaluation on a publicly available dataset, we have demonstrated the capability of the proposed Swin-based model to accurately identify lung cancer lesions. By scaling the Swin-Base model and optimizing model parameters, such as adjusting depth and window size, a more effective and efficient detection process has been achieved, resulting in both improved computational efficiency and diagnostic accuracy.

The findings of this research highlight the potential of attention-based models in medical image analysis, offering promising opportunities to enhance lung cancer diagnosis and patient care outcomes. The utilization of advanced deep learning techniques, including data augmentation and transfer learning, further enhances the generalization ability and performance of the models.

Moving forward, the insights gained from this study can guide the development of stronger and more accurate deep learning models for lung cancer detection and other medical imaging tasks. Continued research in this field can make significant contributions to advancing early diagnosis and treatment of lung cancer, ultimately improving patient outcomes and healthcare delivery.

REFERENCES

- [1] I. Martínez-Reyes, N.S. Chandel, Cancer metabolism: looking forward, *Nat. Rev. Cancer*. 21 (2021) 669–680. <https://doi.org/10.1038/s41568-021-00378-6>.
- [2] R.L. Siegel, K.D. Miller, N.S. Wagle, A. Jemal, Cancer statistics, 2023, *CA. Cancer J. Clin.* 73 (2023) 17–48. <https://doi.org/10.3322/caac.21763>.
- [3] P. Guan, K. Yu, W. Wei, Y.L. Tan, J. Wu, Big Data Analytics on Lung Cancer Diagnosis Framework With Deep Learning, *IEEE/ACM Trans. Comput. Biol. Bioinforma. PP* (2023) 1–12. <https://doi.org/10.1109/TCBB.2023.3281638>.
- [4] R. Raza, F. Zulfiqar, M.O. Khan, M. Arif, A. Alvi, M.A. Iftikhar, T. Alam, Lung-EffNet: Lung cancer classification using EfficientNet from CT-scan images, *Eng. Appl. Artif. Intell.* 126 (2023) 106902.

<https://doi.org/10.1016/j.engappai.2023.106902>.

- [5] M.A. Heuvelmans, P.M.A. van Ooijen, S. Ather, C.F. Silva, D. Han, C.P. Heussel, W. Hickeys, H.U. Kauczor, P. Novotny, H. Peschl, M. Rook, R. Rubtsov, O. von Stackelberg, M.T. Tsakok, C. Arteta, J. Declerck, T. Kadir, L. Pickup, F. Gleeson, M. Oudkerk, Lung cancer prediction by Deep Learning to identify benign lung nodules, *Lung Cancer*. 154 (2021) 1–4. <https://doi.org/10.1016/j.lungcan.2021.01.027>.
- [6] G. Chassagnon, C. De Margerie-Mellon, M. Vakalopoulou, R. Marini, T.N. Hoang-Thi, M.P. Revel, P. Soyer, Artificial intelligence in lung cancer: current applications and perspectives, *Jpn. J. Radiol.* 41 (2023) 235–244. <https://doi.org/10.1007/s11604-022-01359-x>.
- [7] S.H. Hosseini, R. Monsefi, S. Shadroo, Deep learning applications for lung cancer diagnosis: A systematic review, *Springer US*, 2024. <https://doi.org/10.1007/s11042-023-16046-w>.
- [8] B.R. Pandit, A. Alsadoon, P.W.C. Prasad, S. Al Aloussi, T.A. Rashid, O.H. Alsadoon, O.D. Jerew, Deep learning neural network for lung cancer classification: enhanced optimization function, *Multimed. Tools Appl.* 82 (2023) 6605–6624. <https://doi.org/10.1007/s11042-022-13566-9>.
- [9] C. de Margerie-Mellon, G. Chassagnon, Artificial intelligence: A critical review of applications for lung nodule and lung cancer, *Diagn. Interv. Imaging*. 104 (2023) 11–17. <https://doi.org/10.1016/j.diii.2022.11.007>.
- [10] A. Alsadoon, G. Al-Naymat, A.H. Osman, B. Alsinglawi, M. Maabreh, M.R. Islam, DFCV: a framework for evaluation deep learning in early detection and classification of lung cancer, *Springer US*, 2023. <https://doi.org/10.1007/s11042-023-15238-8>.
- [11] P.M. Shakeel, M.A. Burhanuddin, M.I. Desa, Automatic lung cancer detection from CT image using improved deep neural network and ensemble classifier, *Neural Comput. Appl.* 34 (2022) 9579–9592. <https://doi.org/10.1007/s00521-020-04842-6>.
- [12] I. Pacal, D. Karaboga, A. Basturk, B. Akay, U. Nalbantoglu, A comprehensive review of deep learning in colon cancer, *Comput. Biol. Med.* 126 (2020) 104003. <https://doi.org/10.1016/j.compbiomed.2020.104003>.
- [13] M. Alaftekin, I. Pacal, K. Cicek, Real-time sign language recognition based on YOLO algorithm, *Neural Comput. Appl.* (2024). <https://doi.org/10.1007/s00521-024-09503-6>.
- [14] M. Lubbad, D. Karaboga, A. Basturk, B. Akay, U. Nalbantoglu, I. Pacal, Machine learning applications in detection and diagnosis of urology cancers: a systematic literature review, *Neural Comput. Appl.* 2 (2024). <https://doi.org/10.1007/s00521-023-09375-2>.
- [15] I. Pacal, MaxCerVixT: A novel lightweight vision transformer-based Approach for precise cervical cancer detection, *Knowledge-Based Syst.* 289 (2024) 111482. <https://doi.org/10.1016/j.knosys.2024.111482>.
- [16] I. Pacal, Enhancing crop productivity and sustainability through disease identification in maize leaves: Exploiting a large dataset with an advanced vision transformer model, *Expert Syst. Appl.* 238 (2024). <https://doi.org/10.1016/j.eswa.2023.122099>.
- [17] F. Shamshad, S. Khan, S.W. Zamir, M.H. Khan, M. Hayat, F.S. Khan, H. Fu, Transformers in medical imaging: A survey, *Med. Image Anal.* 88 (2023). <https://doi.org/10.1016/j.media.2023.102802>.
- [18] H. Qiu, S. Ding, J. Liu, L. Wang, X. Wang, Applications of Artificial Intelligence in Screening, Diagnosis, Treatment, and Prognosis of Colorectal Cancer, (2022). <https://doi.org/10.3390/curroncol29030146>.
- [19] I. Leblebicioglu, M. Lubbad, O. Melis, D. Yilmaz, K. Kilic, D. Karaboga, A. Basturk, B. Akay, U. Nalbantoglu, S. Yilmaz, M. Ayata, I. Pacal, A robust deep learning model for the classification of dental implant brands, *J. Stomatol. Oral Maxillofac. Surg.* (2024).
- [20] P. Marentakis, P. Karaiskos, V. Kouloulis, N. Kelekis, S. Argentos, N. Oikonomopoulos, C. Loukas, Lung cancer histology classification from CT images based on radiomics and deep learning models, *Med. Biol. Eng. Comput.* 59 (2021) 215–226. <https://doi.org/10.1007/s11517-020-02302-w>.
- [21] T.L. Chaunzwa, A. Hosny, Y. Xu, A. Shafer, N. Diao, M. Lanuti, D.C. Christiani, R.H. Mak, H.J.W.L. Aerts, Deep learning classification of lung cancer histology using CT images, *Sci. Rep.* 11 (2021) 1–12. <https://doi.org/10.1038/s41598-021-84630-x>.
- [22] W.J. Sori, J. Feng, A.W. Godana, S. Liu, D.J. Gelmecha, DFD-Net: lung cancer detection from denoised CT scan image using deep learning, *Front. Comput. Sci.* 15 (2021). <https://doi.org/10.1007/s11704-020-9050-z>.
- [23] Y. Lecun, Y. Bengio, G. Hinton, Deep learning, *Nature*. 521 (2015) 436–444. <https://doi.org/10.1038/nature14539>.
- [24] S. Khan, M. Naseer, M. Hayat, S.W. Zamir, F.S. Khan, M. Shah, Transformers in Vision: A Survey, *ACM Comput. Surv.* 54 (2022) 1–41. <https://doi.org/10.1145/3505244>.
- [25] I. Pacal, A novel Swin transformer approach utilizing residual multi-layer perceptron for diagnosing brain tumors in MRI images, *International Journal of Machine Learning and Cybernetics* (2024). <https://doi.org/10.1007/s13042-024-02110-w>.
- [26] Z. Liu, Y. Lin, Y. Cao, H. Hu, Y. Wei, Z. Zhang, S. Lin, B. Guo, Swin transformer: Hierarchical vision transformer using shifted windows, in: *Proc. IEEE/CVF Int. Conf. Comput. Vis.*, 2021: pp. 10012–10022.
- [27] H.F. Al-Yasriy, M.S. Al-Husieny, F.Y. Mohsen, E.A. Khalil, Z.S. Hassan, Diagnosis of Lung Cancer Based on CT Scans Using CNN, *IOP Conf. Ser. Mater. Sci. Eng.* 928 (2020). <https://doi.org/10.1088/1757-899X/928/2/022035>.
- [28] H.F. Kareem, M.S. AL-Husieny, F.Y. Mohsen, E.A. Khalil, Z.S. Hassan, Evaluation of SVM performance in the detection of lung cancer in marked CT scan dataset, *Indones. J. Electr. Eng. Comput. Sci.* 21 (2021) 1731–1738. <https://doi.org/10.11591/ijeecs.v21.i3.pp1731-1738>.

- [29] The IQ-OTH/NCCD lung cancer dataset, (n.d.). <https://www.kaggle.com/datasets/hamdallak/the-iqothnccd-lung-cancer-dataset> (accessed March 4, 2024).
- [30] hamdalla alyasriy, M. AL-Huseiny, The IQ-OTH/NCCD lung cancer dataset, 4 (2023). <https://doi.org/10.17632/BHMDR45BH2.4>.
- [31] K. He, X. Zhang, S. Ren, J. Sun, Deep residual learning for image recognition, Proc. IEEE Comput. Soc. Conf. Comput. Vis. Pattern Recognit. 2016-Decem (2016) 770–778. <https://doi.org/10.1109/CVPR.2016.90>.
- [32] G. Huang, Z. Liu, L. van der Maaten, K.Q. Weinberger, Densely Connected Convolutional Networks, (2016). <http://arxiv.org/abs/1608.06993>.
- [33] F. Chollet, Xception: Deep Learning with Depthwise Separable Convolutions, (2016). <http://arxiv.org/abs/1610.02357>.
- [34] A. Dosovitskiy, L. Beyer, A. Kolesnikov, D. Weissenborn, X. Zhai, T. Unterthiner, M. Dehghani, M. Minderer, G. Heigold, S. Gelly, J. Uszkoreit, N. Houlsby, An Image is Worth 16x16 Words: Transformers for Image Recognition at Scale, ICLR 2021 - 9th Int. Conf. Learn. Represent. (2020). <https://arxiv.org/abs/2010.11929v2> (accessed August 7, 2023).
- [35] H. Touvron, M. Cord, M. Douze, F. Massa, A. Sablayrolles, H. Jégou, Training data-efficient image transformers & distillation through attention, (2020) 1–22. <http://arxiv.org/abs/2012.12877>.



Geri Dönüşüm Noktalarının Harita Üzerinde Mobil Cihazlar Kullanılarak Belirlenmesi

Ezgi Melda ERDOĞAN^{1*}, Seda TUNCER ARSLAN^{2*}

¹Jeodezi ve Fotogrametri /Fen Bilimleri Enstitüsü, Fırat Üniversitesi, Türkiye

²Yazılım Mühendisliği/Fen Bilimleri Enstitüsü, Fırat Üniversitesi, Türkiye

*(yilmazezgimelda@gmail.com,satuncer@firat.edu.tr)

Özet – Gelişen dünya beraberinde büyüyen ekolojik sorunlarında beraberinde getirmektedir. Üretim ile doğru orantılı olarak tüketim oranlarının artmasıyla atık problemleri ortaya çıkmaktadır. Atık problemleri gerekli önlemler alınmadığı takdirde hem doğa hem de tüm canlı ekosistemi için büyük bir tehdit oluşturmaktadır. Aynı zamanda alınan önlemlerin sürdürülebilir olması atık probleminin çözümünde önemli bir rol oynamaktadır. Bu nedenle hali hazırda kullanılmakta olan geri dönüşüm kutularının daha etkin ve verimli kullanılması adına gelişen ve neredeyse tüm dünyaya hitap eden teknolojik gelişmelerden faydalanılarak global ve sürdürülebilir bir çözüm üretilmesi gerekmektedir. Bu çalışmada mobil uygulama kullanılarak geri dönüşüm kutularının lokasyonlarının bulunabilmesi için kolay ve alternatif bir yöntem geliştirilmiştir. Böylece atık yönetiminde toplumun hem katılım oranını hem de kullanım sıklığını artırmak amaçlanmaktadır. Çalışma ile bireylerin bu kutulara erişiminin daha aktif hale gelmesi ve geri dönüşüm kutularının kullanım oranının artırılması beklenmektedir.

Anahtar Kelimeler – Geri Dönüşüm, Mobil Cihazlar

I. GİRİŞ

Çevresel kirlilik problemi küresel bir sorundur ve birçok etkeni içinde barındırmaktadır. Bu etkenlerden biri de üretim-tüketim akışı içerisinde oluşan atıklar ve bu atıkların doğaya karışmasıdır. Bu atıkların büyük bir kısmı geri dönüştürülebilir atıklardan oluşmaktadır. Geri dönüşüm çevreye yönelik tahribatın önüne geçmek adına büyük etki yaratabilmekte aynı zamanda enerji tasarrufu sağlayabilmektedir. Bu sebeple geri dönüşümün desteklenmesi ve teşvik edilmesi gezegenimiz için bir zorunluluk halini almaktadır[1].

Zehirli kimyasal madde içermeyen boya ların, kullanımı bitmiş ürünlerin çöp olarak son bulması yerine teknik bir dönüşümle yeniden üretime geçirmek çevresel bir yaklaşım olarak değerlendirilmektedir. Çünkü üretilen her ürün çöp olacak şekilde üretilmekte ve bunun geri dönüşüm amaçlı kullanılması avantajlı olmayacağı gibi doğaya da zarar vermektedir [2].

Bu nedenle geri dönüşümü özendirmek ve miktarı arttırmak için bir çok çalışma yapılmaktadır.

İstanbul Belediyesi tarafından ülkemizde mevcut geri dönüşüm çalışmalarının geliştirilmesi için coğrafi bilgi sistemlerinin sunduğu verileri elde etme, stoklama, analiz etme ve görselleştirme gibi imkanlardan faydalanan bir yazılım uygulaması önerisi yapılmıştır [8]. Çalışmada geri dönüşüm projelerinde halkla birebir ilişki içinde olan yerel yönetimlerin önemli görevleri olduğu belirtilmektedir ve İstanbul ilçe belediyelerinin bu konuda yürütmüş olduğu çalışmalar incelenmektedir. Bu çalışmalara öneri olarak sunulan yazılım ile toplumun geri dönüşüm konusunda bilinçlendirilmesi ve bu sürece dahil edilmesi gerektiği belirtilmektedir.

Büyükçekmece Belediyesi vatandaşlara geri dönüşümün nasıl olması gerektiğini, atık toplama noktalarını ve bu noktalara ulaşım sağlayan rotaları gösteren bir portal geliştirmiştir [8]. Geri dönüşüm çalışmalarında mobil uygulama kullanan bir başka şehir ise Hong Kong yerel yönetimidir. Uygulamada; atık ayrıştırma türleri ve yöntemleri hakkında bilgi, atık toplama noktaları, rotasyon, atıkların toplandığı gün ve saat takvimi ve hatırlatıcılar bulunmaktadır [9].

İstanbul ilinde yapılan çalışmada ambalaj atıklarının geri dönüşüme kazandırılmasının maliyet analizini karakterizasyona dayalı olarak yapmıştır. Amacı evsel atık içerisindeki ambalaj atığı miktarı ile ayrı olarak toplanan ambalaj atığı miktarını kıyaslamak ve ayrı olarak toplanma durumunda bunun maliyetinin hesaplanmasını sağlamaktır. Çalışmada atık oluşumunda iki önemli nokta olan nüfus ve katı atık üretim miktarı vurgulanmıştır. Ülkemizde uygulanan katı atık toplama uygulamalarının sınıflandırma açısından yetersizliği belirtilmiş, kaynağında ayrıştırma işleminin daha verimli olacağı üzerinde durulmuştur [3].

Işık F. ve arkadaşları Manisa ilinde yaptıkları çalışmada uzakta algılama yöntemlerini kullanarak çöp toplama alanlarının çevreye olan etkilerini araştırmışlardır. Çalışmada QGIS yazılımı kullanılarak yakınlık ve kesişim analizi yapılmıştır. Çalışma ile ilde yapılacak kapasite büyütme girişiminin şehrin büyük bir popülasyonu etkileyeceği kanısına varılmıştır [4].

Yıldırım ve ark. yaptığı çalışmada DOKAP bölgesinde düzenli depolama alanları için yer tespiti çalışması yapılmıştır. Çalışmada, Kentsel Katı Atıkların (KKA) toplanması ve depolanması ve Düzenli Katı Atık Depolama Alanları (DÜKADA) için kullanılacak yer seçiminde konumsal tabanlı modeller oluşturulmuştur. Çalışmada SiSeGIS ve ArcGIS 10.4 yazılımı kullanılarak en elverişli DÜKADA alanları alternatif seçenekleriyle birlikte tespit edilmeye çalışılmıştır. Çalışma sonucunda 42 adet düzenli katı atık toplama alanı tespit edilmiş. Bu seçenekler arasından maliyet kıyaslaması ve gerekli kurum ve kişilerin görüşleri alınarak 14 bölgeye karar verilmiştir. Karar verilen 14 bölgenin jeolojik ve çevresel test ve analizleri yapılarak çalışma için uygunluğu ispat edilmiştir [5].

Ciritci ve ark. katı atık depolama alanı tespiti için Sivas ilini baz alarak yapmış olduğu çalışmada coğrafi bilgi sistemi ve çok ölçütlü karar verme yöntemleri kullanılarak bir ara yüz elde edilmiştir. Çalışmada ArcGIS yazılımı kullanılarak seçilebilecek konumların kısıtlayıcı sebepleri belirlenmiştir. Analiz sonucu yer tespiti için kısıtlayıcı faktörlerin yerleşim yerlerine ve akarsulara uzaklık, arazinin eğimi, arazi kullanımı, karayolları, imar durumu, havaalanı gibi 11 farklı ölçüt tespit edilmiştir. Bu çalışmanın literatürdeki diğer benzer çalışmalardan en önemli farkı, geliştirilen kullanıcı ara yüz programı ile analizlerin daha hızlı ve etkin bir şekilde yapılarak sonuca ulaşılmasıdır [6].

Çakır ve ark. Şanlıurfa ilindeki Suruç Belediyesine ait sahada bulunan katı atık toplama sisteminin etkilediği beşeri yapıyı, atık miktarını ve yol ağlarını inceleyerek bir veri sistemi oluşturmuştur. Elde edilen verilerden faydalanılarak katı atıkların toplanması ve güzergah oluşturulması adına çalışmalar yapılmıştır. Çalışmada katı atık haritalama işleminde ArcGIS 10.5 yazılımı kullanılmıştır. CBS sisteminin kullanıcının faydalanabileceği formatta olmasını sağlamak için ise Global Mapper 17 yazılımı kullanılmıştır. Çalışma sonucunda Dijkstra Algoritmasının en düşük maliyetli ve en kısa yolu sağlayan algoritma olduğu kanısına varılmıştır [7].

Ülkemizde belediyeler tarafından 2022 yılında 30,3 milyon ton atık toplanmıştır. Bu atıkların % 85,9'u atık işleme tesislerine, %13,5'i belediye çöplüklerine gönderilirken, %0,6'sı ise açıkta yakılarak, gömülerek, dereye veya araziye dökülerek bertaraf edilmiştir [10]. Atık toplama kutularının örnek görselleri Şekil 1.'deki gibidir.



Şekil 1. Atık toplama kutuları örnek görseli

II. MATERYAL VE YÖNTEM

Bu çalışmada Haritalarda Geri Dönüşüm Konumlarını Gösteren Mobil Uygulama gerçekleştirilirken ana materyaller ve teknolojiler aşağıdaki gibidir:

Kotlin: Bu çalışmada temel programlama dili olarak Kotlin kullanılmıştır. Bu dil, hızlı ve verimli yazılım geliştirme ve platformlar arası uyum sağladığı için tercih edilmektedir.

Kotlin Compose: Bu çalışma, kullanıcı arayüzünü oluşturmak için Kotlin Compose, Android için modern bir deklaratif UI toolkitini kullanmıştır.

Android Studio: Android Studio, bu çalışmada kullanılan temel geliştirme ortamıdır. Bu IDE, Android uygulamaları geliştirmek için gerekli tüm araçları ve özellikleri sunmaktadır.

Google Maps API: Bu API, uygulamanın harita özelliklerini sağlar. Kullanıcıların belirli geri dönüşüm noktalarını görmelerine ve bulmalarına olanak sağlamaktadır.

ArcGIS: Coğrafi verileri kullanarak haritalar oluşturmakta, bu haritalar üzerinden veri akışı, derleme, analiz, görselleştirme, katman oluşturma ve oluşturulan bilgi sistemini paylaşabilme gibi birçok özelliğe sahip bir yazılımdır. Bu sayede elimizdeki verileri kullanarak coğrafi temelli bir harita oluşturmamızı sağlamaktadır.

Android Architecture Components: Bu bileşenler, veri yönetimi ve UI durumunun kontrolü için kullanılır. ViewModel ve LiveData gibi bileşenler bu kapsamda kullanıldı.

Bu materyaller ve teknolojiler, bu çalışma için gerekli işlevselliği sağlamak ve kullanıcılarına değerli bir deneyim sunmak için birlikte çalışması amaçlanmıştır.

2.1. Android Uygulama Tasarımı Ve Geliştirme

Veriler Elazığ Belediyesinden tedarik edilmiştir. Elazığ Belediyesinden alınan konumlar Excel'e aktarılmıştır. Belediye tarafından yerleştirilen atık toplama kutuları ikiye ayrılmaktadır. Bunlardan birincisi kağıt/cam ayrışımı yapan ikili geri dönüşüm kutularıdır. Diğeri ise tekstil geri dönüşüm kutularıdır. Elazığ ilinde kategorisine göre geri dönüşüm kutu sayıları Tablo 1.' de gösterilmiştir.

Tablo 1. Tekstil geri dönüşüm kutularına ait koordinat listesi

Kategori	Sayı
Tekstil Geri Dönüşüm	200
Kağıt/Cam geri dönüşüm	186

Ardından android ile uyumlu olan JSON dosya türüne dönüştürülüp çalışmaya entegre edilmiştir. Geri Dönüşüm Konumlarının Gösterimi, Konum Bazlı Hizmetler, Arama ve Filtreleme, Kullanıcı Hesabı Yönetimi ve Bilgi ve Eğitim gibi başlıklar altında gereksinim analizleri yapılarak çalışmanın hangi ihtiyaçlara cevap vereceği belirlenmiştir. Elazığ/Merkez’de yer alan 100 adet tekstil geri dönüşüm kutusundan 10 tanesine ait koordinat listesi Tablo 2. de verilmiştir.

Tablo 2. Tekstil geri dönüşüm kutularına ait koordinat listesi

Nokta No	Koordinat	Nokta No	Koordinat(X,Y)
1	38.66208, 39.23248	6	38.66712, 39.20407
2	38.66942, 39.26129	7	38.67219, 39.17933
3	38.66709, 39.28887	8	38.65243, 39.15373
4	38.65836, 39.14992	9	38.66529, 39.19862
5	38.66691, 39.15289	10	38.65836, 39.17309

2.2. Kullanıcı Arayüzü Tasarımı ve Kodlama

Arayüz tasarımı uygulamanın kullanılabilirliğini ve kullanıcı deneyimini doğrudan etkileyen önemli bir faktör olmaktadır. Bu çalışmada, Kullanıcı Arayüzü (UI), Kotlin Compose kullanılarak geliştirilmiştir. Kotlin Compose, modern, deklaratif bir UI aracı kitidir ve Android UI geliştirmeyi kolay ve verimli hale getirmektedir.

2.3. Yazılım Kodlama

Yazılım kodlama, uygulamanın işlevselliğini belirleyen anahtar süreç olmaktadır. Bu çalışmada, Kotlin dili ve Kotlin Compose framework’ü kullanılmıştır. Kotlin, nesne yönelimli ve fonksiyonel programlama özelliklerini bir arada sunan, güvenli ve yüksek performanslı bir programlama dili olması sebebiyle kullanılmıştır. Kotlin ile Uygulama Strüktürü: Uygulama, belirli işlevselliklere sahip modüllere ayrılmıştır. Bu, kodun okunabilirliğini ve bakımını kolaylaştırmaktadır. Her modül, belirli bir görevi yerine getirmek için tasarlanmıştır ve birbirleriyle düşük bağımlılığa sahip olmaktadır.

Kotlin Compose ile UI Bileşenleri: Compose, UI’nin deklaratif bir biçimde tanımlanmasını sağlamaktadır. Bu, UI bileşenlerini düzenlemeyi ve durumlarına bağlı olarak güncellemeyi kolaylaştırmaktadır. Böylece, harita görüntüleme, arama ve filtreleme gibi her bir UI bileşeni için Composable fonksiyonlar oluşturulmuştur.

Veri Yönetimi: Bu uygulamada veri yönetimi, LiveData ve ViewModel gibi Android Architecture Components kullanılarak yapılmaktadır. Bu bileşenler, veri değişikliklerini takip etmekte ve UI’ı otomatik olarak güncellemektedir. Ayrıca, Google Maps’in sunmuş olduğu imkanlar, geri dönüşüm konumları için API verilerini almak ve işlemek için kullanılmaktadır. Şekil 2. ve Şekil 3.’te uygulamaya ait ekran görüntüleri aktarılmıştır.



Şekil 2. Android Çalışmasında Kağıt ve Cam Geri Dönüşüm Konumlarını Gösteren Sayfa

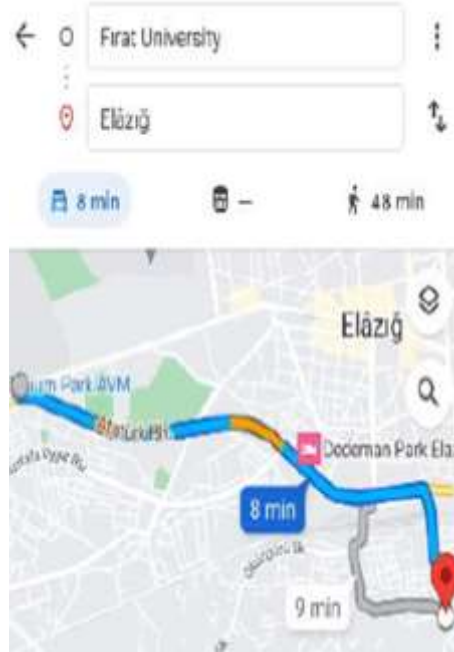

Şekil 3. Android Çalışmasında Yol Tarifini Gösteren Sayfa

2.4. Uygulamanın Test Edilmesi

Hata Yönetimi: Hataların ve istisnaların etkili bir şekilde yönetilmesi, uygulamanın kararlılığı ve güvenilirliği için hayati önem taşımaktadır. Bu nedenle, try-catch blokları, veri işleme ve API istekleri sırasında olası hataları yakalamak ve uygun yanıtlar sağlamak için kullanılmaktadır.

Testler: Yazılımın kalitesini ve güvenilirliğini sağlamak için birim ve entegrasyon testleri yazıldı. JUnit ve Espresso gibi araçlar, kodun doğru çalıştığını ve UI'nın beklenildiği gibi davrandığını doğrulamak için kullanılmaktadır.

"Haritalarda Geri Dönüşüm Konumlarını Gösteren Mobil Uygulama'nın test süreci, bir dizi farklı test tekniğini içerir:

Birim Testleri: Bu testler, uygulamanın temel işlevlerini doğrulamaktadır. Her birim testi, belirli bir fonksiyonun veya metodun doğru çıktığı verip vermediğini kontrol eder. Bu çalışmada, JUnit gibi araçlar birim testlerini gerçekleştirmek için kullanılmaktadır.

Entegrasyon Testleri: Bu testler, uygulamanın farklı bileşenlerinin birlikte nasıl çalıştığını değerlendirir.

Kullanılabilirlik Testleri: Bu testler, uygulamanın kullanıcı dostu olup olmadığını belirler. Gerçek kullanıcıların uygulamayı kullanması ve deneyimleri üzerine geri bildirim vermesiyle gerçekleştirilir. Bu süreç, uygulamanın kullanıcı ara yüzünün kullanıcı dostu olup olmadığını belirlemektedir.

III. BULGULAR

Bu çalışmanın sonuçları şu ana noktalara dayanmaktadır:

Performans: Uygulama, hızlı yanıtlar ve düzgün kullanıcı deneyimi sunarak yüksek performanslı olduğunu kanıtlamıştır. API isteklerinin hızı ve veri işleme yetenekleri, uygulamanın genel performansını olumlu bir şekilde etkilemiştir.

Kullanıcı Deneyimi: Kullanıcı geri bildirimleri genel olarak olumlu olmuştur. Kullanıcı geri bildirimleri için Anket çalışmaları düzenlenmiştir. Kullanıcılar, uygulamanın kullanım kolaylığını, hızını ve geri dönüşüm konumlarını bulma özelliğini özellikle takdir etmişlerdir.

Doğruluk: Uygulama, belirlenen gereksinimleri karşılayacak şekilde doğru ve güvenilir veriler sunmuştur. Geri dönüşüm noktalarının doğru konumları, uygulamanın değerini artıran bir unsur olmuştur.

Elde edilen bulgular, çalışmanın başarısını doğrulamaktadır. Uygulamanın yüksek performansı, doğruluk ve kullanıcı deneyimi, teknolojinin sürdürülebilirliği destekleme potansiyelini göstermektedir. Ayrıca, Kotlin Compose'un deklaratif UI yaklaşımı, etkileyici ve kullanıcı dostu bir arayüz oluşturma konusunda etkili olduğunu kanıtlamıştır.

IV. TARTIŞMA

Bu bölümde çalışmaya ait limitasyonlar belirtilmiştir. Elde edilen bulgular, çalışmanın gelecekteki yönelimlerini ve potansiyel iyileştirmeleri belirlemeye yardımcı olabilir.

Bu çalışma teknolojinin geri dönüşüm ve sürdürülebilirlik çabalarını nasıl destekleyebileceğine dair somut bir örnektir. Çalışma, geri dönüşüm noktalarını bulmayı kolaylaştırarak ve daha geniş bir kitleye ulaşarak toplumun geri dönüşüm alışkanlıklarını iyileştirme potansiyeline sahip bir araç geliştirmiştir.

Bu çalışma, Kotlin dilinde ve Kotlin Compose UI toolkit kullanılarak, kullanıcı dostu ve performansı yüksek bir mobil uygulama geliştirmenin mümkün olduğunu gösterdi. Testler ve kullanıcı geri bildirimleri, uygulamanın istenen özellikleri başarıyla yerine getirdiğini ve kullanıcıları için değerli bir deneyim sağladığını doğrulamıştır. Böylece geri dönüşüme ulaşım kolaylaştırılarak, kullanım oranı artışı sağlanmıştır.

V. SONUÇLAR

Bu çalışmada Geri dönüşüm noktalarına olan ulaşım Mobil uygulamalar yoluyla sağlanmış olup, çevresel farkındalığı artırabilir ve sürdürülebilir yaşam biçimlerini teşvik edebilir. "Haritalarda Geri Dönüşüm Konumlarını Gösteren Mobil Uygulama", bu amaç doğrultusunda önemli bir adımı temsil etmektedir.

Gelecek çalışmalarda, bu uygulamanın daha fazla özelliğin eklenmesi ve daha geniş bir coğrafi alana genişletilmesi hedeflenecektir. Bu, uygulamanın etkisini artırabilir ve daha fazla insanı geri dönüşüm yapmaya teşvik edebilir. Bu çalışma, geri dönüşümün önemini vurgulamak ve bu konuda farkındalık yaratmak için teknolojiyi kullanmanın değerli bir yolu olarak hizmet etmektedir.

KAYNAKLAR

- [1] Ö. Özden, *Geri Dönüşümün Çevre ve Ekonomi Açısından Önemi*, İstanbul Üniversitesi, Toplum Hekimliği Uygulama ve Araştırma Merkezi, Orman Fakültesi

- [2] A. Karasu, *Çevresel Atıklar Nedenleri, Çevresel Atıkların Geri Dönüştürülmesi ve Yenilenebilir Enerji Olanaklarının Araştırılması*, Bilecik Şeyh Ebedali Üniversitesi, Fen Bilimleri Enstitüsü Kimya Anabilim Dalı, Bilecik, 2013
- [3] E. Fakıhoğlu, *İstanbul'da Ambalaj Atıklarının Geri Dönüşüm Uygulamalarının Maliyet Analizi*, Tez (Yüksek Lisans) - Yıldız Teknik Üniversitesi, Fen Bilimleri Enstitüsü, 2011
- [4] F. Işık ve D. Çağatay, *Uzaktan Algılama ve Coğrafi Bilgi Sistemi Teknolojilerinin Kentsel Büyümenin İzlenmesi Süreçlerinde Kullanımı: Manisa Örneği, Yerel Politikalar*, 0(6): 0-0, 2014
- [5] V. Yıldırım, *Düzenli depolama Alanları için Yer Tespiti Çalışması ve Alternatif Katı Atık Bertaraf Sistemleri Araştırma Çalışması*, Karadeniz Teknik Üniversitesi Mühendislik Fakültesi Harita Mühendisliği Bölümü GISLab Ar-Ge / Trabzon, 2017
- [6] C. Dilara ve T. Tarık, *Alternatif Katı Atık Depolama Alanlarının Analitik Hiyerarşi Süreci ve Coğrafi Bilgi Sistemleri ile Otomatik Olarak Belirlenmesi: Sivas İli Örneği*, Jeodezi ve Jeoinformasyon Dergisi :06:01, 2019
- [7] M.E. Çakır, A. Demir Yetiş, M.İ. Yeşilçınar ve M. Ulukavak, *Katı Atıklar için Optimum Güzergâh Tespiti ve Alansal Dağılım Haritalarının CBS Ortamında Oluşturulması: Suruç (Şanlıurfa) Örneği*, Bitlis Eren Üniversitesi Fen Bilimleri Dergisi, c. 8, sayı. 2, ss. 595-603, doi:10.17798/bitlisfen.482893, 2019
- [8] URL1:<https://play.google.com/store/apps/details?id=com.bodev.android.atikbuyukcekmece&gl=TR> Erişim: 12 Nisan 2023
- [9] URL2:https://play.google.com/store/apps/details?id=hk.com.codecrafters.wsb&hl=en_US,Erişim: 12 Nisan 2023
- [10] URL3: <https://www.tuik.gov.tr/>



Using Prolog in education, to understand logical thinking and programming concepts, a use case in Albania

Anxhela Kosta¹, Endri Xhina², Ilma Lili³

¹Department of Computer Sciences, University of Tirana, Albania

²Department of Computer Sciences, University of Tirana, Albania

³Department of Computer Sciences, University of Tirana, Albania

*(anxhela.kosta@fshn.edu.al, endri.xhina@fshn.edu.al, ilma.lili@fshn.edu.al)

Abstract – In this paper we will show the use of logic programming (LP) and Prolog in teaching to promote logical thinking and understanding of programming concepts. Prolog is a logic programming language that is based on irregular predicate logic and the Natural Deduction rules of logic. First, it explains how using Prolog helps develop logical thinking skills. Due to Prolog's simple syntax and inherent logic, students can develop structured thinking skills and employ logical rules to tackle intricate problems more effectively. The literature points to problems in learning the language, but also to possible approaches to quality teaching. A primary focus of this research involves a targeted investigation within select schools in Albania, aiming to comprehend the acknowledgment and utilization of the Prolog language. Based on the results of research using Prolog in teaching encourages students to actively participate, experiment with writing logic rules, and see the results immediately. A little demonstration will be shown in this paper to promote interactive learning Artificial Intelligence through the use of Prolog by using Swi-Prolog. This active participation helps develop creativity, analytical skills and problem solving in a structured and logical manner. In conclusion, this paper supports the use of Prolog in teaching to understand logical thinking and programming concepts.

Keywords – Prolog, Teaching, Logic Programming (LP), SWI-Prolog, Artificial Intelligence

I. INTRODUCTION

As we know today, technology has advanced considerably, and we are surrounded by various technological devices such as laptops, PCs, smartphones, tablets, etc. We envision a world where sound reasoning and argumentation are embraced in all aspects of life, particularly in conflict resolution. Logic allows people to think more clearly and holds a central position in human affairs, as truth and (healthy) reasoning play a fundamental role in human thinking. However, learning logic can be challenging, and reasoning can be complex. These difficulties and complexities can be alleviated with Prolog. Prolog is simpler than first-order logic, making it possible for even younger students to understand it. Reasoning with Prolog is easier to follow. Prolog is not only an excellent tool for learning logic but also a great tool for developing computational thinking skills. Computational thinking helps students solve problems using basic concepts such as abstraction, problem decomposition, and recursion. Computational thinking can be specifically realized in Prolog, making it an excellent tool for teaching computer programming to students at all levels, including young children. To facilitate this, students and teachers, regardless of their location and time zone, need the support of the global academic community and access to the latest pedagogical tools. In conclusion, learning Prolog for young students is important as it enables them to develop a systematic way of thinking through the use of logic and acquire knowledge in the field of computer programming.

This will be demonstrated in a survey we have done in some schools in Albania. The aim of the (surveys) are to illustrate why there is a need for the learning and use of the Prolog language in education, examining its impact on teaching and its positive aspects. Since Artificial Intelligence keeps getting better every day, Prolog will keep getting better too, moving along with how fast AI is growing.

II. PROLOG AND ITS USE

Prolog is a logic programming language. It plays a significant role in artificial intelligence. Unlike many other programming languages, Prolog is primarily intended as a declarative programming language. In Prolog, logic is expressed as relationships. The logic programming language PROLOG (Programming in Logic) was conceptualized by Alain Colmerauer at the University of Aix-Marseille, France, where the language was first implemented in 1973. PROLOG was further developed by the logician Robert Kowalski, a member of the AI group at the University of Edinburgh [1]. Prolog evolved from research at the University of Aix-Marseille in the late '60s and early '70s. Alain Colmerauer and Philippe Roussel, both from the University of Aix-Marseille, collaborated with Robert Kowalski from the University of Edinburgh to create the foundational model of Prolog as we know it today. In Prolog, we don't have to mention how a problem can be solved; we just need to specify what the problem is so that Prolog can solve it automatically. However, in Prolog, we are supposed to provide data as a solution method. The components of Prolog are [9]:

Facts – A fact is a statement that is true; for example, if we say, "Tom is the son of Jack," then this is a fact.

Rules – Rules are deductions from facts containing conditional clauses. To fulfill a rule, these conditions must be satisfied. For instance, if we define a rule as: `grandfather(X, Y) :- father(X, Z), parent(Z, Y)` This implies that for X to be the grandfather of Y, Z must be the parent of Y, and X must be the father of Z.

Queries – To execute a Prolog program, we need queries, and these queries can be answered by the facts and rules provided.

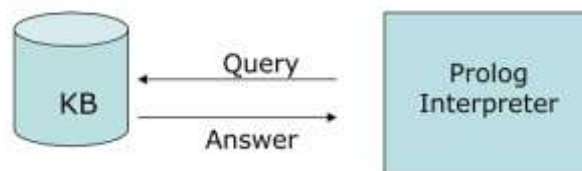

Fig. 1 Prolog ask based DB knowledge

The primary applications of the language can be found in the field of artificial intelligence, but PROLOG is also being used in other areas where symbolic manipulation is equally crucial. [6] Some fields of Prolog application include:

- Machine Learning
- Robotics
- Problem-solving
- Specification
- Database Retrieval
- Natural Language Understanding
- Automation systems

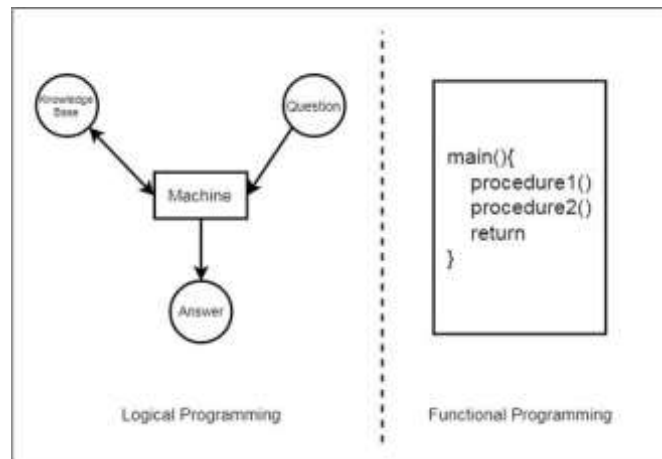

Fig. 2 Logical, Functional Programming

Functional Programming defines procedures and specifies how these procedures work step by step to solve a specific problem based on the algorithm. On the other hand, for Logic Programming, we provide a knowledge base. Utilizing this knowledge base, the machine can find answers to given questions, which is entirely different from functional programming. In functional programming, we need to mention how a problem can be solved, but in logic programming, we need to specify for which problem we actually want the solution. Then, logic programming automatically finds a suitable solution that will help us solve that specific problem [3].

Table 1. Difference between Functional and Logical Programming.

Functional Programming	Logical Programming
It is totally based on functions.	It is totally based on formal logic
programs are constructed by applying and composing functions.	program statements usually express or represent facts and rules related to problems within a system of formal logic.
Programming follows the Von Neumann Architecture or uses the following steps.	Logic Programming uses an abstract model or deals with objects and their relationships.
It simply uses functions.	It simply uses predicates.

A good interpreter to use Prolog is SWI-Prolog [10] . This should be installed on your computer and used for writing queries. Bellow is an example

Table 2. Example of Prolog

Function	Description	Response
?-dog(jane).	[Is Jane a dog? No - a cat]	false.
?- animal(fido).	[Is fido an animal?] [yes - because it is a dog and any dog is an animal]	true.
?- dog(X).	[Is it possible to find anything, let us call it X, that is a dog?] [All 3 possible answers are provided]	X= fido; X= rover; X= henry
?- animal(felix)	[felix is a cat and so does not qualify as an animal, as far as the program is concerned]	false.

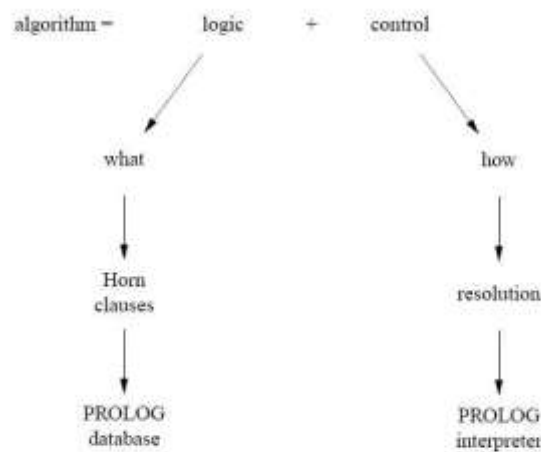

The relationship between PROLOG and logic programming.

Fig. 3 Logical and Prolog

III. PROLOG IN EDUCATION

End of 1970, Prolog emerged as a potentially powerful tool for elementary education.[4] Early experiments in teaching children Prolog programming suggested that it improved their logical thinking, a finding later confirmed. In 1982, a PROLOG project in Exeter followed the same course, but by 1985, it transitioned to using Prolog Knowledge-Based Intelligent Systems (IKBS). These IKBS take the form of authoring predicates that enable students to represent their understanding of a subject as a computer program written in English [5]. Predicates have been applied in teaching Humanities, children with Specific Learning Difficulties (SLD - Dyslexia), and in the elementary curriculum. Work has also been done in language instruction and teacher training. The article describes various aspects of the curriculum development project at the University of Exeter, which has developed and implemented Prolog IKBS [5]. Understanding Prolog programming is a challenge for many beginners, and numerous instructors and researchers have proposed and adopted various teaching approaches to help students grasp Prolog easily. However, it is unknown whether any of the teaching methods currently in use are suitable from the student's perspective [4].

IV. ADVANTAGE AND DISADVANTAGE OF PROLOG

Some of the advantages of incorporating Prolog at work are as follows [8] [9]:

- **Declarative Programming**:- Prolog is a declarative programming language that focuses on "what" needs to be achieved rather than "how" to achieve it. This allows for concise and expressive code, making it easier to write and understand complex logic. [7]
- **Logical Reasoning** : Prolog is based on logic and provides a natural way to express and reason about problems using rules and facts. It excels in domains that require symbolic reasoning and intelligent problem-solving.
- **Built-in Backtracking** : Prolog has built-in backtracking capabilities, allowing it to explore multiple solutions to a problem. This makes it well-suited for tasks such as search algorithms, constraint satisfaction problems, and expert systems.
- **Pattern Matching and Unification** : Prolog's powerful pattern matching and unification capabilities make it efficient at matching complex data structures and solving problems involving pattern recognition, parsing, and symbolic manipulation.
- **Rapid Prototyping** : Prolog's high-level abstraction and concise syntax make it suitable for rapid prototyping and experimentation. It allows developers to quickly test ideas and explore different problem-solving approaches.

In the other hand there are also some cons [8][12]:

- **Limited Performance for Certain Tasks:** Prolog may not perform as well as other languages, particularly for tasks that require extensive number crunching or low-level system operations. It may not be the best choice for performance-critical applications.
- **Steep Learning Curve:** Prolog's unique declarative and logic-based paradigm can be challenging for developers accustomed to imperative or object-oriented programming. Understanding and effectively utilizing Prolog's features and the underlying unification mechanism may require a learning curve.
- **Limited Library Ecosystem :** Compared to more mainstream languages, Prolog has a smaller library ecosystem and fewer available resources, frameworks, and tools. This may require more effort to find and integrate third-party libraries or develop specific functionalities from scratch.
- **Lack of Standardization :** There are several Prolog dialects available, and each dialect may have its own syntax, features, and quirks. This lack of standardization can create compatibility issues when porting code between different Prolog implementations.
- **Not Suitable for Every Problem :** While Prolog is powerful for certain problem domains, it may not be the best choice for all types of applications. Tasks that heavily rely on mutable state, complex algorithms with intricate control flow, or real-time systems may be better suited for other languages

V. USE CASE IN ALBANIA

In recent years, as technologies such as video projectors, smart boards, computers, software, the internet, tablets, mobile devices, etc., have been integrated into the education system, teaching resources have changed considerably. Educators believe that there are many advantages to using technology in the classroom, such as: it makes the student more interested in the subject matter, reduces learning time, and provides opportunities for non-traditional learning.[23] To understand the importance of technology in the educational process, we pose the question of how and to what extent the use of technological devices in primary and lower secondary education would stimulate students' motivation to learn, engage them during teaching and learning activities, and how much technology would support learning methods. To answer this question, explaining the role and significance of technology in the teaching process, educational methodists have conducted numerous studies during which they have observed that the use of various technological devices in the classroom truly presents distinct benefits. They emphasize that interviews with teachers, students, parents, and classroom observations show that the motivation and concentration of students during learning activities increase when they use technological devices to complete these tasks. [12]

[13] Logical Programming has received much critical attention over the past two decades from both a linguistic perspective and as a methodology for practical problem-solving. An analysis of Prolog's use in commercial, research, and educational environments indicates the existence of an established user base, and after a period of rapid growth, the language currently has a slowly growing profile. The key to its success so far lies in its continuous evolution through the incorporation of features not initially seen within the concept of a pure logical language. Important features that have contributed to the success of Prolog include integration with other languages, object-oriented-oriented expansions, representation constraints, parallel execution, as well as improved speed and stability. Factors contributing to the success of Prolog are identified, and possible future developments are explored [2]. As an academic instructional language, Prolog is frequently used in universities and colleges, not only as an AI language but also as a language where students are exposed to problem-solving to focus solely on execution [27]. Various surveys have been conducted in England, Germany, etc., regarding the Prolog programming language, and the responses have been mostly positive towards its use in education. Therefore, it is a language that would also be recommended in Albania and its schools.

Despite the fact that the Prolog programming language is well-known and applied in several different countries worldwide, the situation is not the same in Albania. In our country, this language is not widely recognized. To precisely understand how well Prolog is known in Albania and what chances it has for use in education, we have conducted two surveys, one directed towards teachers and another towards several companies. Both surveys are constructed with 10 questions, where the main focus is on the recognition of Prolog in Albania and how likely it is to be used. We did the survey to 18/20 high schools to see if they teach Prolog in laboratories or if they have knowledge of this language. Based on the statistics gathered from the first survey, directed to some teachers from "Arben Broci" High School, Tirana, "Ismail Qemali", "Petro Nini Luarasi", and "Sami Frasherri" High School, Tirana, we can say that the Prolog programming language was unknown to them, but it was well received for implementation in education in Albania. The charts below present the more detailed percentage responses for the most important questions:

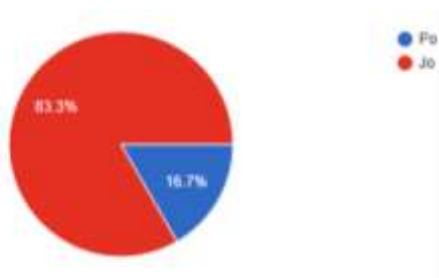

Question 1: Did you have difficulty during learning coding?

As seen from the above graph, the majority of teachers have responded that they have encountered difficulties during the course of instruction. This is due to the subject matter and the level of difficulty it may present.

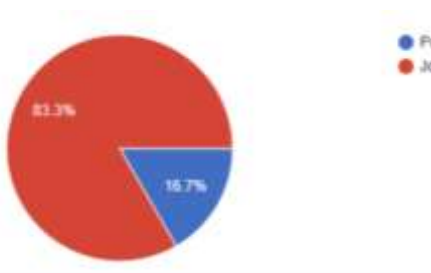

Question 2: If they know the Prolog Language

As seen in the graph, around 83.3% were not aware of Prolog.

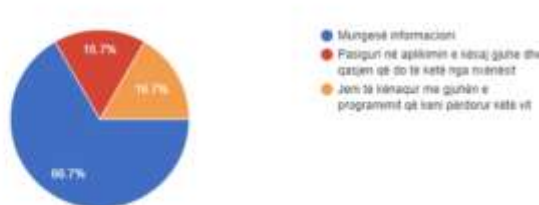

Question 10 : The reason for the non-use of Prolog.

When asked about the factors that would contribute to the non-use of Prolog, the majority of teachers' responses were due to a lack of information

After finishing the first survey we did some open lessons to introduce the Prolog to them. We demonstrated the family tree to understand the logic of Prolog, the rules, facts and queries. At knowledge base we write:

```

/* Facts */
male(jack).
male(oliver).
parent_of(jack,jess).
parent_of(jack,lily).

/* Rules */
father_of(X,Y):- male(X),
parent_of(X,Y).

mother_of(X,Y):- female(X),
parent_of(X,Y).

brother_of(X,Y):- male(X),
mother_of(M, Y), mother_of(M,X),X \= Y.

At Swi prolog we write the queries
/*query*/
?-mother_of(jess,helen).
?-brother_of(X,lily).

```

After this open lesson (workshop) we did the second survey and asked both teachers and young students if they want to use and learn Prolog.

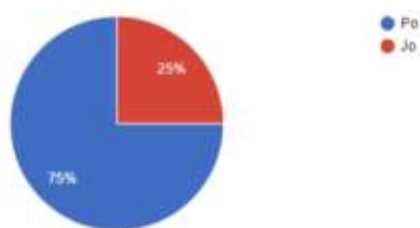

Question 11 : After this demonstration, do you see the Prolog useful?

As can be seen from the graph, the majority have responded that Prolog and its usage would facilitate their work, so they would use it.

VI. FUTURE OF PROLOG

In the future, the most influential Prolog books will be those that clearly expose the pure essence of Prolog and the unique advantages and possibilities of applying logic programming, along with limitations such as:

- declarative correction
- declarative integer
- arithmetic combined optimization.

By fully embracing such concepts and utilizing them to their maximum advantage, future generations can finally witness and benefit from the true power of Prolog. [26]

In Albania there are too many laboratories in Artificial Intelligence that will use Prolog for students in high school.

VII. CONCLUSION

The purpose of this paper was to present the existing works related to the Prolog programming language and the advantages it has if it can be used in education, also in our country Albania. Numerous academic and scientific papers were reviewed, gathering all the results achieved so far. In some countries, Prolog has been used and proved successful in the teaching process, as it is a declarative language.

A practical demonstration of Prolog was presented in multiple high schools across Albania, aiming to explain the logic and the importance of Prolog. Our results show that students and teachers were able to focus on logical programming and problem solving within the declarative programming paradigm. As an academic instructional language, Prolog is frequently used in universities and colleges, not only as an AI language but also as a language where students are exposed to problem-solving[26] to focus solely on execution. Various surveys have been conducted in England, Germany, Italy etc., regarding the Prolog programming language, and the responses have been mostly positive towards its use in education(high school). Therefore, it is a language that would also be used in Albania and its schools.

VIII. RECOMMENDATION

This paper focused on the use of the Prolog language and its implementation in teaching, in addition to education, has practical value in other fields as in various companies that operate with AI, etc. Many functionalities of this device are quite useful. The study showed that this language was not known in our country, but as shown, the feedback received from the questionnaires was positive. We recommend the use of Prolog firstly to every school and university, as it helps and improves the educational process, secondly we recommend it to companies that deal with data collection and have a lot of things to memorize, to companies that use artificial intelligence.

REFERENCES

- [1] Bramer, Max (2005): Logic Programming with Prolog.
- [2] Darby-Dowman, Ken (1997): Critical Factors in the Evolution of Logic Programming and Prolog.
- [3] YUANLIN ZHANG, MARITZA REYES, TIMOTHY T. YUEN, Introducing Computer Science to High School Students through Logic Programming(2003)
- [4] Yang, Shanshan (December 15, 2015): Approaches for Learning Prolog Programming.
- [5] Nichol, Jon (July 9, 2006): PROLOG in the Classroom.
- [6] Harrison, A. (1994): Prolog as a first programming language.
- [7] Bramer, Max (2005): Logic Programming with Prolog. Second Edition.
- [8] (Pears et al. 2007; Chakravarty and Keller 2004; Scherz and Haberman 1995; Ball and Zorn 2015
- [9] Agna's Blog (October 26, 2010): An Introduction To Prolog : Rules and Fact.
- [10] SWI-Prolog: <https://www.swi-prolog.org/>
- [11] Bramer, Max (2005): Logic Programming with Prolog. Second Edition.
- [12] R. P. Gabriel, (1993): The End of History and the Last Programming Language, Journal of Object Oriented Programming.
- [13] Moss, Halfway (1993): The Prolog Thousand ,Logic programming - The Newsletter of the Association for Logic Programming.
- [14] Carlsson, Mats (November 19, 1991): SICStus Prolog User's Manual.
- [15] Brogi, Antonio (January 1, 1991): The concurrent language, Shared Prolog.
- [16] Clark, KL (1981): IC-PROLOG LANGUAGE FEATURES.
- [17] Triska, Markus (2005): The Future of Prolog.
- [18] Zhou, Nf (2012): The language features and architecture of B-Prolog.
- [19] Korner, Phillip (2022): Fifty Years of Prolog and Beyond.
- [20] Gupta, Gopal (2003): Next Generation of Logic Programming Systems. 58
- [21] Jos e J ulio Alferes, Lu ís Moniz Pereira, and Terrance Swift (2004): Abduction in well- founded semantics and generalized stable models via tabled dual programs.
- [22] Vitor Santos Costa, Ines de Castro Dutra, and Ricardo Rocha (2010): Threads and or- parallelism unified.
- [23] Hanus, Michael (2022): From Logic to Functional Logic Programs.
- [24] Erik T. Mueller. (2014): Commonsense reasoning: an event calculus based approach. Morgan Kaufmann.
- [25] Robert A. Kowalski. (1979): Logic for Problem Solving.
- [26] Matteo Baldoni, Cristina Baroglio, Viviana Patti, and Paolo Rena. From tags to emotions: Ontology-driven sentiment analysis in the social semantic web. *Intelligenza Artificiale*, 6(1):41–54, 2012.



Heart Disease Classification Using Random Forest Machine Learning

Muhammet Çakmak*

¹Computer Engineering, Faculty of Engineering and Architecture, Sinop University, Sinop

*(mcakmak@sinop.edu.tr) Email of the corresponding author

Abstract – Heart disease classification is a critical task in healthcare, aiming to diagnose patients and provide timely treatment accurately. In this study, we employed Random Forest machine learning algorithms to classify heart disease based on a comprehensive dataset encompassing demographic, clinical, and diagnostic attributes. The dataset, originating from 1988 and comprising four databases, namely Cleveland, Hungary, Switzerland, and Long Beach V, contains 76 attributes. However, our analysis focused on a subset of 14 key attributes, including age, sex, chest pain type, resting blood pressure, serum cholesterol levels, and more. Our Random Forest model demonstrated exceptional performance metrics through rigorous evaluation compared to other machine learning methods. While Ada Boost, Gradient Boosting, Naive Bayes, and Logistic Regression achieved accuracies ranging from 80% to 93%, Random Forest excelled with an accuracy of 99%. The Random Forest model significantly outperformed its counterparts with precision, recall, and f1-scores exceeding 97% for both classes (0 and 1). This indicates the model's robust ability to accurately classify instances of both the absence and presence of heart disease. The ensemble nature of Random Forest allows for effective feature selection and handling of complex interactions within the dataset, resulting in superior classification performance. Our study contributes to advancing heart disease diagnosis by showcasing the efficacy of Random Forest machine learning algorithms in accurately predicting heart disease based on diverse patient attributes. The high accuracy and performance metrics attained underscore the potential of machine learning in improving diagnostic accuracy and patient outcomes in cardiovascular medicine.

Keywords – Heart Disease, Machine Learning, Classification

I. INTRODUCTION

Heart disease is a leading cause of death globally, claiming millions of lives annually. Early diagnosis and timely treatment are crucial in reducing heart disease-related mortality and improving patient outcomes. In the past few years, machine learning algorithms have surfaced as a promising asset in the realm of healthcare, presenting opportunities to improve diagnostic precision and optimize clinical decision-making processes.

Rapidly developing technology has caused artificial intelligence applications to affect all sectors rapidly [1], [2]. To date, machine learning and deep learning applications have been used in many fields, such as technology [1], [3], health [4], economy [5], commerce [6], cyber security [7], education [8] and agriculture [9]. Determining the disease classification through the observation and experience of an experienced expert is a process that takes a long time and lacks accurate prediction [10].

This study aims to investigate the efficacy of Random Forest machine learning algorithms in classifying heart disease based on a comprehensive dataset encompassing demographic, clinical, and diagnostic attributes.

The dataset used in this study originates from 1988 and comprises four databases, namely Hungary, Cleveland, Long Beach V and Switzerland containing 76 attributes. However, our analysis focused on a subset of 14 key attributes, including age, sex, chest pain type, resting blood pressure, serum cholesterol levels, and more. The primary objective of this study is to evaluate the performance of the Random Forest

algorithm in accurately predicting heart disease based on these attributes and compare it to other machine learning methods.

Several machine learning algorithms, including Ada Boost, Gradient Boosting, Naive Bayes, and Logistic Regression, were employed for comparison purposes. The results demonstrate that while these algorithms achieved accuracies ranging from 80% to 93%, the Random Forest model excelled with an accuracy of 99%. The Random Forest model significantly outperformed its counterparts with precision, recall, and f1-scores exceeding 97% for both classes (0 and 1). This indicates the model's robust ability to accurately classify instances of both the absence and presence of heart disease.

The ensemble nature of Random Forest allows for effective feature selection and handling of complex interactions within the dataset, resulting in superior classification performance. The high accuracy and performance metrics attained in this study underscore the potential of machine learning in improving diagnostic accuracy and patient outcomes in cardiovascular medicine. By showcasing the efficacy of Random Forest machine learning algorithms in accurately predicting heart disease based on diverse patient attributes, this study contributes to advancing heart disease diagnosis and paving the way for more personalized and effective treatment strategies.

II. LITERATURE

Heart disease is a significant public health issue, affecting millions of people worldwide. Over the years, researchers have proposed various methods for diagnosing heart disease, ranging from traditional clinical approaches to more recent machine learning-based methods. In this section, we review the relevant literature on heart disease diagnosis, with a particular focus on machine learning-based approaches.

Traditional methods for diagnosing heart disease include clinical evaluation, electrocardiography (ECG), stress testing, and coronary angiography. However, these methods have limitations, such as low sensitivity and specificity, high cost, and invasiveness. Machine learning-based approaches, on the other hand, offer the potential to overcome these limitations by enabling accurate and non-invasive diagnosis.

Several studies have explored using machine learning algorithms for heart disease diagnosis. For instance, Mohapatra et al. [11] proposed a prediction model for heart disease prediction using various classifiers at two levels (Basic level and Meta level). The model achieved 92% accuracy in prediction with a sensitivity and precision score of 92.6%, specificity of 91%. Similarly, Rajendran and Karthi [12] used an Entropy based Logistic Regression and Naive Bayes to predict heart disease based on a dataset containing 14 attributes, achieving an accuracy of 92.7%. In another study, Roy et al. [13] applied an Exception deep learning method to classify heart disease, achieving a sensitivity of 98.5% and specificity of 98.7%.

Random Forest is an ensemble learning algorithm that has shown promising results in various classification tasks. In the context of heart disease diagnosis, several studies have explored the use of Random Forest. For instance, Siddiqui et al. [14] applied a Random Forest algorithm to classify heart disease based on a dataset containing 14 attributes, achieving an accuracy of 95.8%. Similarly, Asadi et al. [15] employed a Hybrid Random Forest algorithm to predict heart disease based on a dataset, achieving an accuracy of 88.26%.

In this study, we aim to fill this gap by evaluating the performance of the Random Forest algorithm for heart disease diagnosis based on a comprehensive dataset containing 14 key attributes and comparing it with several other machine learning algorithms. The results of this study have the potential to advance heart disease diagnosis and improve patient outcomes by enabling accurate and timely diagnosis.

III. MATERIALS AND METHOD

A. Dataset

In this study, we utilized a comprehensive dataset to classify heart disease using Random Forest machine learning algorithms. The dataset originates from 1988 and comprises four distinct databases, namely Hungary, Cleveland, Long Beach V and Switzerland containing 76 attributes; however, our

analysis focused on a subset of 14 key attributes, selected based on their relevance to heart disease diagnosis. Age, sex, chest pain type, resting blood pressure, serum cholesterol, fasting blood sugar, resting electrocardiographic results, maximum heart rate, exercise-induced angina, ST depression, slope of the peak, number of major vessels, Thalassemia, heart disease: The target variable, indicating the presence or absence of heart disease (1 = presence, 0 = absence).

Figure 1 shows the distribution of age, Thalassemia and Serum Cholesterol data in the dataset.

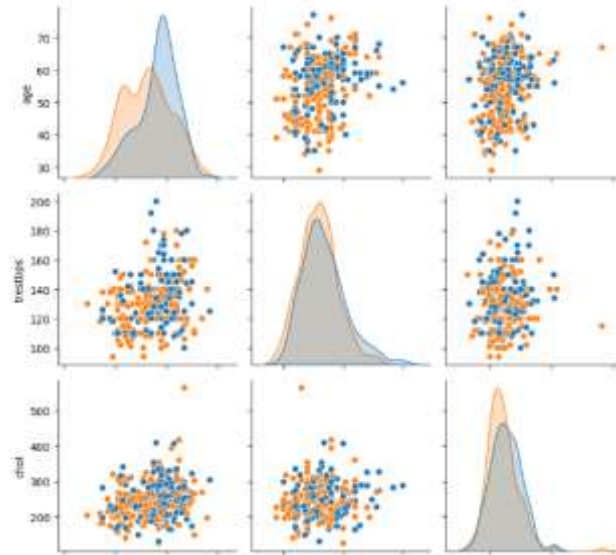

Fig. 1 Distribution of some sample data in the dataset

B. Machine Learning Methods

In this study, we employed five popular machine learning algorithms, namely Random Forest, Ada Boost, Gradient Boosting, Naive Bayes, and Logistic Regression, to classify heart disease based on a comprehensive set of demographics, clinical, and diagnostic attributes.

Random Forest stands out as an ensemble learning technique that harnesses the power of multiple decision trees to enhance classification accuracy. It uses a bagging technique to randomly select a subset of features and instances for each decision tree, which reduces overfitting and enhances generalization. Random Forest also provides feature importance scores, which can be used for effective feature selection.

Ada Boost and Gradient Boosting are boosting algorithms that iteratively train weak learners to improve the overall performance of the model. Ada Boost assigns higher weights to misclassified instances in each iteration, while Gradient Boosting uses gradient descent to minimize the loss function. Both algorithms have shown to be effective in handling complex interactions within the dataset.

Naive Bayes stands as a probabilistic technique grounded on Bayes' theorem, operating under the assumption of feature independence given the class label. Despite its straightforwardness, Naive Bayes showcases commendable performance across diverse classification assignments, particularly benefiting from extensive datasets and feature independence.

Logistic Regression is a linear model used for binary classification problems. It models the probability of the target variable given the input features using a logistic function. Logistic Regression is widely used in healthcare due to its interpretability and ease of implementation.

C. Experimental Study

The measurements given in Table 1 and Figure 2 show the performance of the RF model on the binary classification task, especially in classifying heart disease cases. With a precision of 97% for class 0 and 100% for class 1, the model demonstrates high accuracy in correctly identifying instances of both the absence and presence of heart disease. The recall rates of 100% for class 0 and 97% for class 1 indicate the model's ability to capture the majority of true instances within each class effectively.

Table 1. Classification report of Random Forest

Random Forest				
	precision	recall	f1-score	support
	0.97	1.00	0.99	102
	1.00	0.97	0.99	103
accuracy			0.99	205
macro avg	0.99	0.99	0.99	205
weighted avg	0.99	0.99	0.99	205

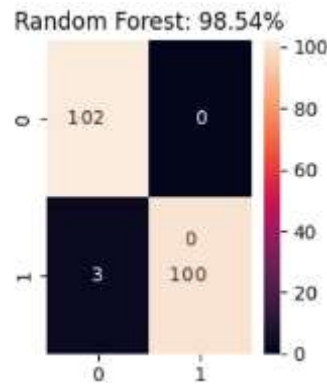

Fig. 2 Random Forest confusion matrix

The F1-score, which combines precision and recall into a single metric, also reflects a high level of performance for both classes, reaching 99%. The overall accuracy of 99% further emphasizes the model's effectiveness in accurately classifying heart disease cases. These results suggest that the Random Forest model is highly reliable and robust in its predictions, making it a valuable tool for assisting in the diagnosis and management of heart disease in clinical settings.

The measurements given in Table 2 and Figure 3 show the performance of the Ada Boost model on the binary classification task, especially in classifying heart disease cases. With precision scores of 87% for class 0 and 89% for class 1, the model exhibits a high level of accuracy in correctly identifying instances of both absence and presence of heart disease. The recall rates of 89% for class 0 and 86% for class 1 indicate the model's ability to capture the majority of true instances within each class effectively.

Table 2. Classification report of Ada Boost

Ada Boost				
	precision	recall	f1-score	support
	0.87	0.89	0.88	102
	0.89	0.86	0.88	103
accuracy			0.88	205
macro avg	0.88	0.88	0.88	205
weighted avg	0.88	0.88	0.88	205

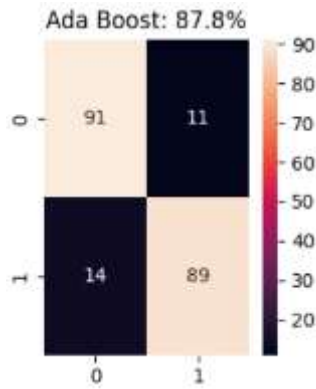

Fig. 3 Ada Boost confusion matrix

Additionally, the F1-score, which balances precision and recall, attains 88% for both classes, reflecting a harmonious performance in terms of both positive and negative cases. The overall accuracy of 88% underscores the model's capability to make accurate predictions across the dataset. These results suggest that the Ada Boost model holds promise as a reliable tool for aiding in the diagnosis and prognosis of heart disease, contributing to more effective patient care and management strategies.

The measurements given in Table 3 and Figure 4 show the performance of the Gradient Boosting model on the binary classification task, especially in classifying heart disease cases. The metrics provided for the Gradient Boosting model indicate its strong performance in classifying heart disease cases. With a precision of 95% for class 0 and 92% for class 1, the model demonstrates high accuracy in correctly identifying instances of both the absence and presence of heart disease. The recall rates of 91% for class 0 and 95% for class 1 suggest the model's effectiveness in capturing the majority of true instances within each class. Additionally, the F1-score, which considers both precision and recall, reaches 93% for both classes, highlighting a balanced performance in terms of both positive and negative cases. The overall accuracy of 93% further emphasizes the model's capability to make accurate predictions across the dataset.

Table 3. Classification report of Gradient Boosting

Gradient Boosting				
	precision	recall	f1-score	support
	0.95	0.91	0.93	102
	0.92	0.95	0.93	103
accuracy			0.93	205
macro avg	0.93	0.93	0.93	205
weighted avg	0.93	0.93	0.93	205

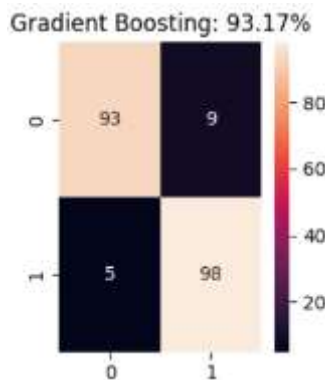

Fig. 4 Gradient Boosting Confusion Matrix

The measurements given in Table 4 and Figure 5 show the performance of the Ada Boost model on the binary classification task, especially in classifying heart disease cases. With a precision of 87% for class 0

and 75% for class 1, the model demonstrates a relatively higher accuracy in identifying instances of no heart disease compared to those with heart disease. The recall rates of 71% for class 0 and 89% for class 1 indicate the model's ability to correctly capture the majority of true instances within each class, with a particularly high recall rate for class 1. The F1-scores, which consider both precision and recall, reach 78% for class 0 and 82% for class 1, suggesting a reasonably balanced performance in terms of both positive and negative cases. The overall accuracy of 80% indicates the model's effectiveness in making accurate predictions across the dataset, albeit with some variability in performance between the two classes.

Table 4. Classification report of Naïve Bayes

Naïve Bayes				
	precision	recall	f1-score	support
	0.87	0.71	0.78	102
	0.75	0.89	0.82	103
accuracy			0.80	205
macro avg	0.81	0.80	0.80	205
weighted avg	0.81	0.80	0.80	205

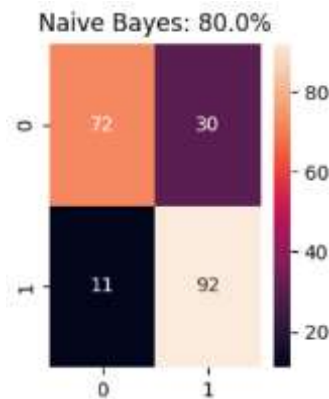

Fig. 5 Naive Bayes confusion matrix

The measurements given in Table 5 and Figure 6 show the performance of the Ada Boost model on the binary classification task, especially in classifying heart disease cases.

Table 5. Classification report of Logistic Regression

Logistic Regression				
	precision	recall	f1-score	support
	0.86	0.73	0.79	102
	0.76	0.88	0.82	103
accuracy			0.80	205
macro avg	0.81	0.80	0.80	205
weighted avg	0.81	0.80	0.80	205

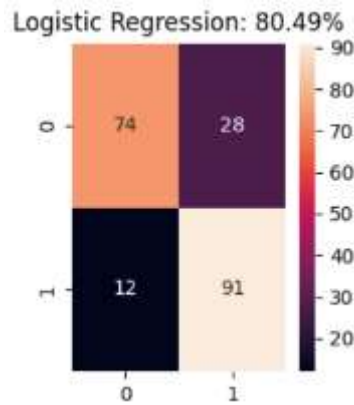

Fig. 6 Logistic Regression confusion matrix

IV. RESULT AND DISCUSSION

The comparative analysis of various machine learning models for heart disease classification provides valuable insights into their performance and suitability for clinical applications.

With an exceptional accuracy of 99%, Random Forest emerges as the top-performing model in accurately classifying instances of heart disease. Its high precision, recall, and F1-score for both disease and non-disease cases highlight its robustness in correctly identifying positive and negative instances. Random Forest's ability to handle complex datasets and capture intricate relationships between features contributes to its superior performance. Despite achieving a slightly lower accuracy of 88% compared to Random Forest, Ada Boost demonstrates commendable performance. Its ensemble learning approach, which combines multiple weak learners to create a strong classifier, enables it to maintain balanced precision, recall, and F1-score for both classes. Gradient Boosting achieves an accuracy of 93% and exhibits balanced performance across precision, recall, and F1-score for both disease and non-disease instances. Its iterative optimization process, where models are sequentially added to correct errors made by previous models, enhances its performance and robustness. Despite its simplicity, Naive Bayes achieves a reasonable accuracy of 80%. However, its precision, recall, and F1-score are comparatively lower than ensemble methods like Random Forest and Gradient Boosting. Naive Bayes' assumption of feature independence may not hold true in complex datasets like heart disease classification, affecting its performance. Logistic Regression, with an accuracy of 80%, demonstrates balanced performance with reasonable precision, recall, and F1-score for both disease and non-disease cases. Its simplicity and interpretability make it suitable for scenarios where model transparency is crucial.

In summary, Random Forest emerges as the top-performing model for heart disease classification, followed closely by Gradient Boosting and Ada Boost. These findings emphasize the significance of employing ensemble methods for accurate and reliable heart disease diagnosis in clinical settings..

V. CONCLUSION

This study evaluated the performance of various machine learning models for heart disease classification, aiming to assess their suitability for clinical applications. The findings demonstrate that Random Forest achieved outstanding accuracy of 99%, making it the most effective model in accurately classifying instances of heart disease. High precision, recall, and F1-score highlight Random Forest's ability to correctly identify both positive and negative instances. Ada Boost and Gradient Boosting performed closely to Random Forest, while Naive Bayes and Logistic Regression obtained lower accuracy rates. These results underscore the importance of employing ensemble methods when dealing with complex clinical data, contributing to the development of reliable and accurate models for diagnosing heart disease.

REFERENCES

- [1] G. Dhanush, N. Khatri, S. Kumar, and P. K. Shukla, "A comprehensive review of machine vision systems and artificial intelligence algorithms for the detection and harvesting of agricultural produce," *Sci Afr*, vol. 21, p. e01798, Sep. 2023, doi: 10.1016/J.SCIAF.2023.E01798.
- [2] S. Schramm, C. Wehner, and U. Schmid, "Comprehensible Artificial Intelligence on Knowledge Graphs: A survey," *Journal of Web Semantics*, vol. 79, p. 100806, Dec. 2023, doi: 10.1016/J.WEBSEM.2023.100806.
- [3] M. Çakmak and Z. Albayrak, "AFCC-r: Adaptive Feedback Congestion Control Algorithm to Avoid Queue Overflow in LTE Networks," *Mobile Networks and Applications*, vol. 27, no. 5, 2022, doi: 10.1007/s11036-022-02011-8.
- [4] N. Lassau *et al.*, "Three artificial intelligence data challenges based on CT and MRI," *Diagn Interv Imaging*, vol. 101, no. 12, pp. 783–788, Dec. 2020, doi: 10.1016/J.DIII.2020.03.006.
- [5] M. Sharma, S. Luthra, S. Joshi, and A. Kumar, "Implementing challenges of artificial intelligence: Evidence from public manufacturing sector of an emerging economy," *Gov Inf Q*, vol. 39, no. 4, p. 101624, Oct. 2022, doi: 10.1016/J.GIQ.2021.101624.
- [6] C. Wang *et al.*, "An empirical evaluation of technology acceptance model for Artificial Intelligence in E-commerce," *Heliyon*, vol. 9, no. 8, p. e18349, Aug. 2023, doi: 10.1016/J.HELİYON.2023.E18349.
- [7] H. C. Altunay and Z. Albayrak, "A hybrid CNN + LSTMbased intrusion detection system for industrial IoT networks," *Engineering Science and Technology, an International Journal*, vol. 38, Feb. 2023, doi: 10.1016/j.jestch.2022.101322.
- [8] E. M. Lim, "Metaphor analysis on pre-service early childhood teachers' conception of AI (Artificial Intelligence) education for young children," *Think Skills Creat*, vol. 51, p. 101455, Mar. 2024, doi: 10.1016/J.TSC.2023.101455.
- [9] S. Oyebisi and T. Alomayri, "Potential application of artificial intelligence to the alpha and gamma radiation from agricultural byproducts used as building and construction materials," *Sci Afr*, vol. 21, p. e01792, Sep. 2023, doi: 10.1016/J.SCIAF.2023.E01792.
- [10] N. Çetin, K. Karaman, E. Kavuncuoğlu, B. Yıldırım, and A. Jahanbakhshi, "Using hyperspectral imaging technology and machine learning algorithms for assessing internal quality parameters of apple fruits," *Chemometrics and Intelligent Laboratory Systems*, vol. 230, p. 104650, Nov. 2022, doi: 10.1016/J.CHEMOLAB.2022.104650.
- [11] S. Mohapatra *et al.*, "A stacking classifiers model for detecting heart irregularities and predicting Cardiovascular Disease," *Healthcare Analytics*, vol. 3, p. 100133, Nov. 2023, doi: 10.1016/J.HEALTH.2022.100133.
- [12] R. Rajendran and A. Karthi, "Heart disease prediction using entropy based feature engineering and ensembling of machine learning classifiers," *Expert Syst Appl*, vol. 207, p. 117882, Nov. 2022, doi: 10.1016/J.ESWA.2022.117882.
- [13] T. S. Roy, J. K. Roy, and N. Mandal, "Classifier identification using deep learning and machine learning algorithms for the detection of valvular heart diseases," *Biomedical Engineering Advances*, vol. 3, p. 100035, Jun. 2022, doi: 10.1016/J.BEA.2022.100035.
- [14] A. Siddiqui, S. Wajahat, and A. Rizvi, "Heart Disease Prediction by using Random Forest Classifier," *Journal of Applied Science and Education (JASE)*, vol. 3, no. 2, pp. 1–9, Nov. 2023, doi: 10.54060/JASE.V3I2.29.
- [15] S. Asadi, S. E. Roshan, and M. W. Kattan, "Random forest swarm optimization-based for heart diseases diagnosis," *J Biomed Inform*, vol. 115, p. 103690, Mar. 2021, doi: 10.1016/J.JBI.2021.103690.



Estimating Forced Convection Behavior of Magnetic Nanofluid in Wavy Tube Using Scaled Conjugated Gradient Algorithm and Feed-Forward Backprop Neural Network

Furkan Yıldırım^{*1}, Mehmet Gürdal²

¹*Institute of Science, Department of Mechanical Engineering, Kastamonu University, Türkiye*

²*Department of Mechanical Engineering, Kastamonu University, Türkiye*

**(furkanyildirim078@gmail.com) Email of the corresponding author*

This study highlights advancements in heat transfer enhancement technology, particularly focusing on passive methods like wavy tape inserts and nanofluids. Studies have investigated the use of nanofluids to improve heat transfer performance, showing promising results in heat exchanger applications. Artificial neural networks (ANNs) have been employed to accurately predict heat transfer efficiency, providing valuable insights for design optimization. A novel approach integrating wavy taped turbulators with magnetic nanofluids has been introduced to comprehensively analyze thermo-hydraulic performance. Computational studies demonstrate the impact of wavy tape inserts on flow and heat transfer characteristics, highlighting improvements in heat convection and friction coefficient. Overall, the findings emphasize the importance of considering factors such as the wave ratio of wavy tape inserts and the type of working fluid in optimizing heat transfer performance in various engineering applications.

Keywords – Heat Transfer, Internal Flow, Nanofluids, Forced Heat Convection, CFD, Artificial Neural Network, MATLAB

I. INTRODUCTION

In order to build a sustainable society, an innovation in heat transfer enhancement technology through forced convection is strongly demanded due to the increasing demand for energy savings and further improvement of the performance and functions of products such as electric vehicles, air conditioning systems and electronic equipment. In order to meet this demand, studies on heat transfer enhancement methods are becoming increasingly dependent on the variability in the size of thermal energy systems and the increase in energy costs [1]. This energy consumption can be avoided by reducing the cost of the system through changes in the design of thermal energy systems. Nowadays, a significant number of researchers are looking for new methods to enhance heat transfer between surfaces and the surrounding fluid. These methods can be categorized into two heat transfer improvement methods: active methods and passive methods. Active methods require external power as an input from outside, such as creating a vibrational flow within the moving fluid to improve heat transfer rates. On the other hand, passive retrofit methods are those that do not require external power to maintain the retrofit properties. Due to their simpler performance and ease of use in new thermal heat exchangers, passive methods have attracted more attention than active ones [2].

Among passive methods, coiled wire and twisted tape inserts are more common than other passive methods [3–5]. Twisted tape inserts inside the heat exchangers induce vortex flow in the direction of the heat exchangers without proper thermal contact with the heat exchanger walls. For twisted tape inserts, the main contribution to the heat transfer increase is due to the effect of the induced vortex. Due to the distortion-induced shape drag and increased turbulence, the pressure drop with flow through an enhanced tube is always greater than that obtained with a straight tube for the same length, flow rate and diameter.

Rahimi et al. [6] report experimental and Computational Fluid Dynamics (CFD) investigations on the friction factor, Nusselt number and thermal-hydraulic performance of a tube equipped with three conventional and three modified twisted tape inserts. The results showed that the Nusselt number and performance of the serrated insert are higher than others. Nakhchi et al. [7] performed a numerical analysis to investigate the flow structure and thermal hydraulic performance of turbulent flow through a circular pipe equipped with twisted bands with different cut shapes. The presence of rectangular cut twisted tape (RCT) has a significant effect on the heat transfer and friction factor in this region, leading to better fluid mixing and centrifugal force near the wall. The results show that both heat transfer and pressure drop depend on the shear rate. [8] et al. developed a 3D numerical model for a straight circular pipe with a diameter of 11.08 mm and a length of 1920 mm using water as the heat transfer fluid and investigated the flow and heat transfer characteristics of water in the pipe. The simulation was performed for a range of Reynolds numbers (1500-24,000) and four bent tape inserts with different widths (1, 2, 2.5 and 3 mm). The results revealed that the twisted tape inserts cause a noticeable vortex in the flow inside the pipe.

Nanofluidics is one of the widely used passive methods in various heat transfer applications recently to improve the thermophysical properties of the working fluid for higher heat transfer performance [9,10]. Ju et al. [11] numerically investigated the hydrothermal performance of multiple semi-twisted tape inserts in a heat exchanger tube in three dimensions. This study aims to find the optimum case to have the highest heat transfer enhancement with the lowest friction factor using nanofluid ($\text{Al}_2\text{O}_3/\text{water}$). It was found that increasing the number of semi-twisted tapes increases the number of swirling flow streams and leads to an increase in the friction factor as well as the local Nusselt number. Dagdevir et al. [12] experimentally investigated the effects of different twisted tapes on the heat transfer and flow characteristics in the heat exchanger tube to improve the performance of a heat exchanger flowing mixtures of ethylene glycol (EG) and water (W). Three different volumetric ratios of EG and W mixtures were used, namely (0:100), (20:80) and (40:60). The results showed that the use of twisted tape inserts improved the heat transfer performance. Hosseinneshad et al. [13] numerically investigated the turbulent flow of water/ Al_2O_3 nanofluid in a tubular heat exchanger with two twisted tape inserts in three-dimensional coordinates. The SIMPLEC algorithm was used for coupling the velocity-pressure equations. The results of this research revealed that by decreasing the twist ratio, the twisted band with counter vortex flow and increasing the volume fraction of Al_2O_3 nanoparticles in the base fluid, the average Nusselt number increases.

Researchers have recently been working on an innovative process approach or method to predict heat transfer efficiency [14–16]. Artificial neural networks have been developed and applied in many different fields to overcome the problem of complex relationship between nonlinear input and output data. Adopting artificial neural network (ANN) method to predict efficiency in various heat remediation processes can be an attractive proposal due to its high accuracy. Ayli et al. [17] conducted a numerical study to investigate the effect of twisted tape splices on heat transfer. The numerical results show that the tube with twisted tape and different number of tapes is more effective than the straight tube in terms of thermo-hydraulic performance. The developed ANN architecture is able to predict the heat transfer improvement performance of similar problems with R2 values higher than 0.93. Khan et al. [18] used an artificial neural network (ANN) to predict the efficiency of a twin-tube heat exchanger using T-W band splices with different fin width ratios (w/W) of 0.31, 0.47 and 0.63. The effects of friction factor (f), Nusselt number (Nu) and thermal performance (η) are predicted using a multilayer ANN. The results prove that the developed ANN model can accurately predict the experimental data. The obtained mean squared error is less than 0.7 compared to the experimental values.

The innovative approach of integrating the twisted band turbulator with the magnetic nanofluid inside the tube channel distinguishes this work from similar studies. Our aim was to comprehensively analyze the thermo-hydraulic performance under certain boundary conditions and present a comparative study by predicting the results of this analysis with an artificial neural network model.

II. MATERIALS AND METHOD

The external diameter of the test tube is 20 mm, and it extends to a length of 1500 mm. These dimensions have been meticulously chosen to ensure the attainment of fully developed thermo-hydrodynamic conditions within the tube. Additionally, the wall thickness of the tube has been precisely determined to be 2 mm. The design of the Wavy Tape Insert (WTI) is defined by a dimensionless parameter denoted as 'y' (w/t), where 'w' (measured in millimeters) indicates the distance between the peaks of the two waves, and 't' (also in millimeters) represents the width of the WTI.

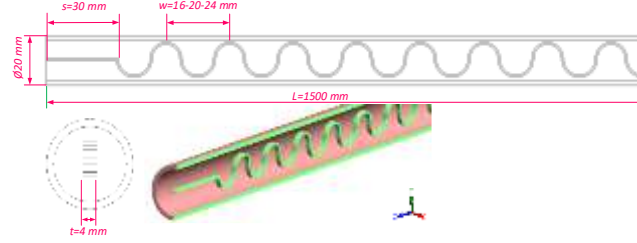

Fig. 1 Channel with wavy tape

All analyses were performed under laminar flow condition ($500 < Re < 2000$). Ansys Fluent, one of the popular CFD programs, was used for the solution of the analyses. SIMPLEX algorithm was preferred as a solution method because it provides faster and consistent results for incompressible and Newtonian fluid analyses. Numerical analyses were executed by applying the principles of continuity, momentum, and energy conservation. The core conservation equations are presented as follows Eq(1), Eq(2), and Eq(3).

Continuity Eq. :

$$\frac{\partial \rho}{\partial t} + \frac{\partial(\rho u_i)}{\partial x} = 0 \quad (1)$$

Momentum Eq. :

$$\frac{\partial(\rho u_i)}{\partial t} + \frac{\partial(\rho u_i u_j)}{\partial x_j} = -\frac{\partial P}{\partial x_i} + \frac{\partial}{\partial x_j} \left[\mu \left(\frac{\partial u_i}{\partial x_j} + \frac{\partial u_j}{\partial x_i} - \frac{2}{3} \delta_{ij} \frac{\partial u_k}{\partial x_k} \right) \right] + i \frac{\partial}{\partial x_j} (-\overline{\rho u'_i u'_j}) \quad (2)$$

Energy Eq. :

$$\frac{\partial}{\partial t} (\rho E) + \frac{\partial}{\partial x_i} [u_i (\rho E + Pr)] = \frac{\partial}{\partial t} \left[\left(k + \frac{c \mu_i}{Pr_t} \right) \right] \frac{\partial T}{\partial x_j} + \mu_i (\tau_{ij})_{eff} \quad (3)$$

Mesh number and properties play an important role in numerical analysis. The mesh serves as a means of discretizing the computational domain, and the number of elements within the mesh has a direct impact on both the accuracy and convergence of the solution. While a finer mesh may yield more precise results, it also increases the computational burden. The subtleties of network design, including element shapes and sizes, also affect the accuracy and stability of the solution. For this study, all mesh refinement iterations were performed at 2000 Reynolds number (Re) to ensure consistency and reliability in the analysis. Thanks to the mesh optimization study, 601140 number of mesh elements was determined as the optimum number of elements for this particular scenario, taking into account the relevant boundary conditions.

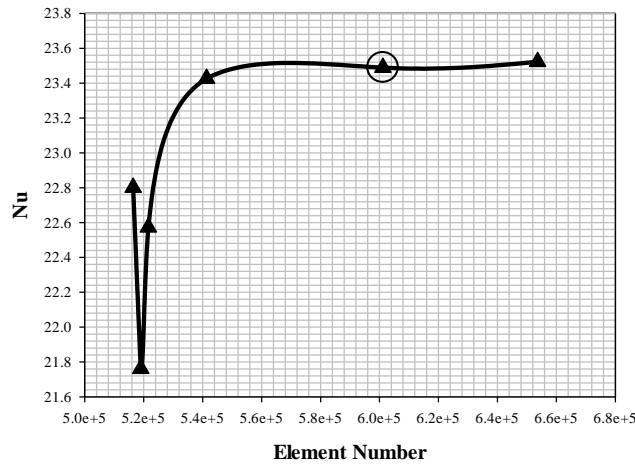
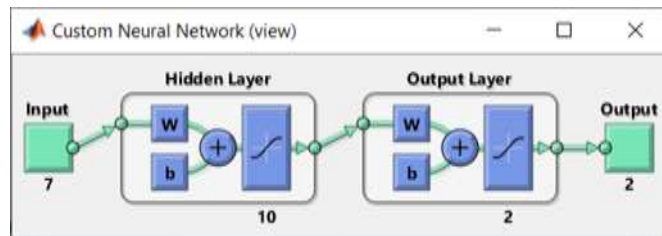
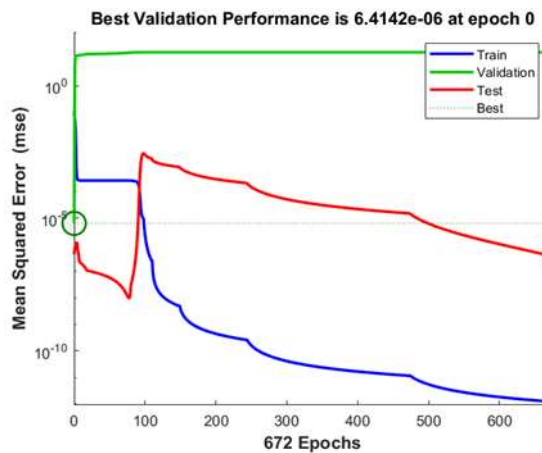

Fig. 2 Mesh Independence Test

ANNs are information processing systems with specific features that work effectively with biological neural networks. ANN is one of the most widely used and developed models for investigating the relationship between linear or nonlinear input-output models. A neural network is a mapping between inputs and outputs based on a set of known sample input-output pairs. ANNs also facilitate training and approximation of the test team. The performance of using ANNs has predictable success. In this study, neural networks were specified using MATLAB program and all tests were performed on the computer. Some of the most important parameters for ANN performance and prediction convergence are Mean Square Error (MSE) and Relation correlation (R^2). MSE value less than 10^0 and R^2 value close to 1 indicate the reliability of the results. The ANN performance indicators obtained in this study are presented in Figure 3(a), Figure 3(b) and Figure 3(c).



(a)



(b)

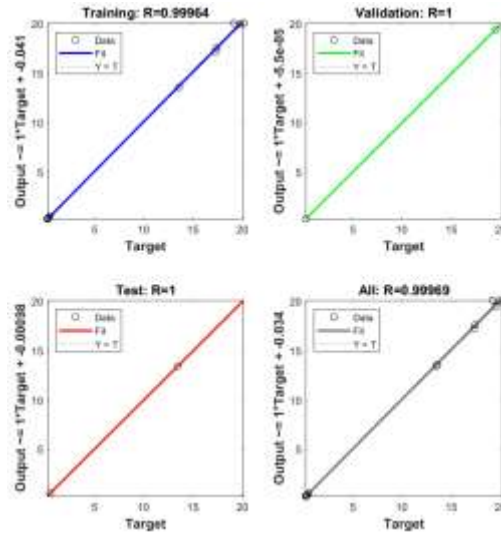

(c)

Fig. 3 (a) A schematic diagram for the deep feed-forward neural network, (b) Varying of MSE values, (c) Varying of R^2 value according to target finding

III. RESULTS

Extensive computational studies have been conducted to investigate the impact of Wavy Tape Inserts (WTI) on the flow and heat transfer characteristics of $\text{CoFe}_2\text{O}_4/\text{H}_2\text{O}$ fluid within a circular tube. The analyses were conducted under laminar flow conditions, specifically within the Reynolds number range of 500 to 2000. A magnetic nanofluid composed of $\text{CoFe}_2\text{O}_4/\text{H}_2\text{O}$ with a volume fraction of 1.0% was utilized as the working fluid. Additionally, a constant and uniform heat flux of 2000 W/m^2 was applied across the surface of the test tube.

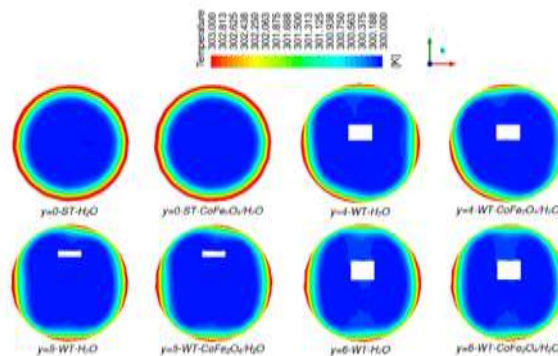

Fig. 4 Temperature distribution

To explore the effects of WTI, three different waveband ratios ($y=4, 5,$ and 6) were employed. The results are presented in terms of average Nusselt number (Nu), Darcy Friction Factor (f), and the variation of PEC (Performance Evaluation Criteria) with Reynolds number and wave ratio. Contour plots depicting temperature and velocity are also provided to elucidate the underlying physical mechanisms of forced convection in both straight and wavy-taped tubes. Results should be clear and concise. The most important features and trends in the results should be described but should not interpreted in detail.

Figure 4 illustrates the temperature distributions for fluid flowing in both Base Fluid (BF) and Nanofluid (NF) within Straight Tubes (ST) and Wavy Taped Tubes (WT) with wave ratios of 4, 5, and 6. The combined use of Wavy Tape Inserts (WTI) and nanoparticles leads to a more significant reduction in tube wall temperature and an increase in temperature gradient, consequently enhancing heat convection compared to Base Fluid (BF), as depicted in Figure 4.

As the dimensionless parameter 'y' decreases, both the Darcy Friction Factor (f) and the Nusselt number (Nu) exhibit substantial enhancements across the tube cross-section. Analyzing the velocity contours for all cases at a distance of z=0.75 m from the tube (as shown in Figure 5), it is evident that the velocity values between CoFe2O4/H2O and water flow do not exhibit significant changes.

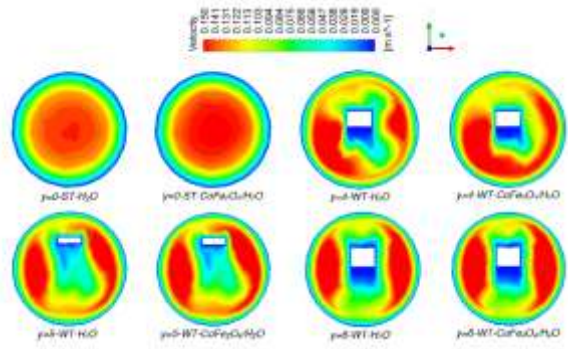

Fig. 3 Velocity distribution

IV. DISCUSSION

IV.A.1 USING WATER AS A WORKING FLUID

The influence of the dimensionless parameter 'y' on the Nu is clearly illustrated in Figure 6. The variation of Nusselt number (Nu) with Reynolds number (Re) for both Straight Tubes (ST) and Wavy Taped Tubes (WT) with different wave ratios is depicted in Figure 6. It is evident from the figures that Nu increases with Re number, as expected, and it also increases with increasing values of 'y'. The highest Nu values are attained at Re=2000. Moreover, increasing the wave ratio results in more vortex formation and boundary layer separation, consequently enhancing forced convection. These phenomena collectively contribute to the overall improvement in Nu. It can be seen that the results are in good agreement with the results obtained in CFD and ANN approach. When the ANN results are analyzed, a deviation of 2.24% is observed when the Nusselt number results obtained in the ANN approach are compared with the Nusselt number results obtained with CFD.

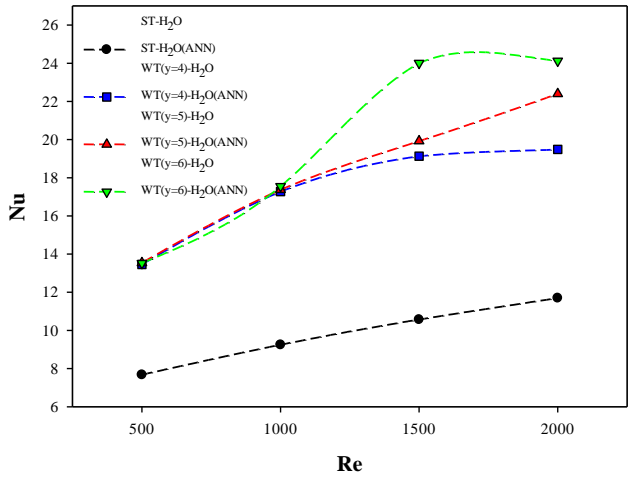

Fig. 6 Varying Nu number for water

In Figure 7, the variation of the Darcy Friction Factor (f) with Reynolds number (Re) for water flow in both Straight Tubes (ST) and Wavy Taped Tubes (WT) with different wave ratios is compared. It is observed that the maximum f value for WT with a wave ratio of 5 and 6 is obtained with a percentage

increase of 627.79% and 326.00%, respectively, compared to the case of ST at Re=2000 and Re=500, respectively.

It can be seen that the results are in good agreement with the results obtained in CFD and ANN approach. When the ANN results are analyzed, a deviation of 2.39% is observed when we compare the Darcy Friction Coefficient (f) results obtained in the ANN approach with the Darcy Friction Coefficient (f) results obtained with CFD.

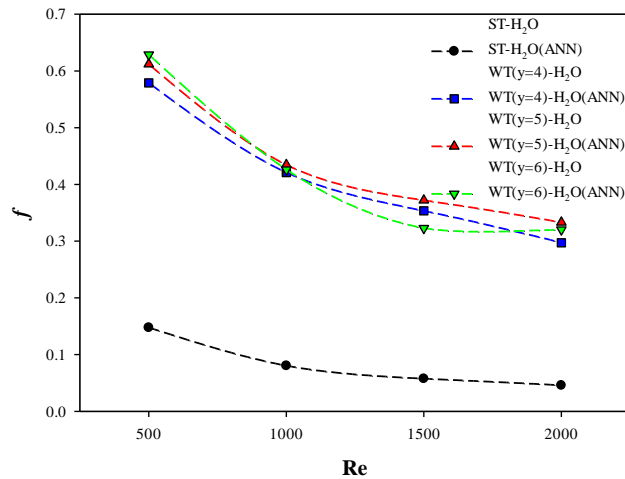

Fig. 7 Varying Darcy Friction Factor for water

To determine the optimal design geometry, Performance Evaluation Criteria (PEC) values for various wave ratios have been simulated and presented in Figure 8 using water flow. It is observed that PEC values remain above 1 for all geometries until Re=1500. Notably, the WT with a wave ratio of 6 exhibits the most stable and consistent results across all flow rates.

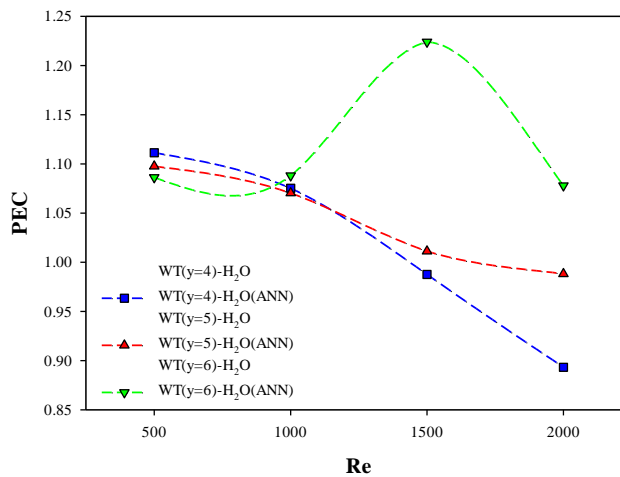

Fig. 8 Varying PEC for water

It can be seen that the results are in good agreement with the results obtained in CFD and ANN approach. When the ANN results are analyzed, a deviation of 4.23% is observed when we compare the PEC results obtained with the ANN approach with the PEC results obtained with CFD. It is seen that the increase in the error rate is caused by the result of Re=1500 at y=6 wave ratio.

IV.A.2 USING NANOFLUID AS A WORKING FLUID

To elucidate the influence of the nanofluid and the Wavy Tape Insert (WTI) on forced heat convection, the variation of average Nusselt number (Nu) with Reynolds number (Re) in the WT ($y=4-5-6$) for a

nanoparticle volume fraction of 1.0 vol.% has been investigated and depicted in Figure 9. As discerned from this figure, the highest Nu values are attained for a y value of 6 at Re=2000. The most significant enhancement in Nu is observed at Re=2000, with an increase of 105.76% compared to CoFe₂O₄/H₂O flow in ST. This underscores the notable augmentation in heat transfer performance facilitated by the combination of a magnetic nanofluid and the utilization of WTI. It can be seen that the results are in good agreement with the results obtained in CFD and ANN approach. When the ANN results are analyzed, a deviation of 5.79% is observed when the Nusselt number results obtained in the ANN approach are compared with the Nusselt number results obtained with CFD. It is seen that the increase in the error rate is caused by the results in the smooth tube and y=5 wave ratio.

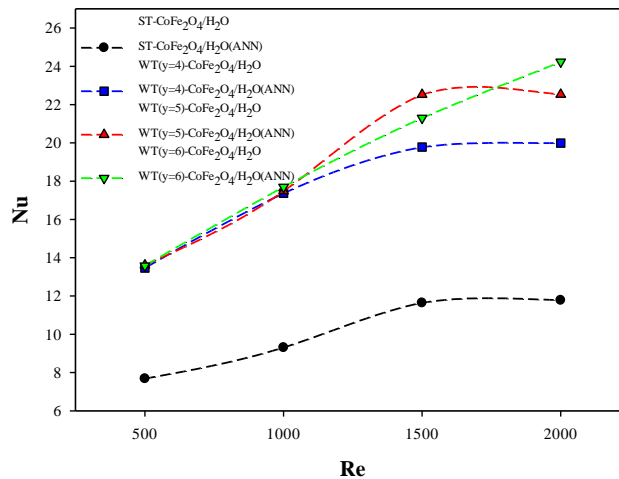

Fig. 9 Varying Nu Number for nanofluid

In Figure 10, the Darcy friction coefficient values resulting from the nanofluid flow in both Straight Tubes (ST) and Wavy Taped Tubes (WT) with different wave ratios are compared across Reynolds numbers. Upon analysis, notable increases are observed with the utilization of WT compared to ST, while altering the wave ratio exerts a greater influence on the friction coefficient (f). Specifically, the increase in the friction coefficient for wave ratios of 4, 5, and 6 compared to ST averages at 452.16%, 482.51%, and 470.94%, respectively. These findings underscore the significant impact of the Wavy Tape Insert (WTI) on enhancing the frictional characteristics of the nanofluid flow, with varying wave ratios playing a discernible role in this effect. It can be seen that the results are in good agreement with the results obtained in CFD and ANN approach. When the ANN results are analyzed, there is a deviation of 8.45% when we compare the Darcy Friction Factor (f) results obtained in the ANN approach with the Darcy Friction Factor(f) results obtained with CFD. It is seen that the increase in the error rate is caused by the results in the smooth tube and y=5 wave ratio.

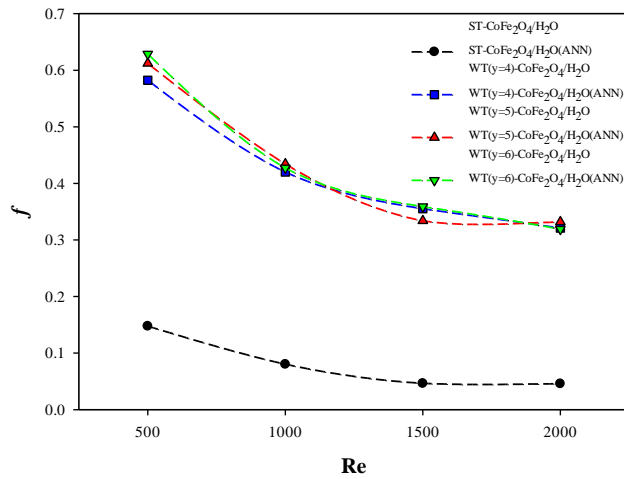

Fig. 10 Varying Darcy Friction Factor for nanofluid

In Figure 11, Performance Evaluation Criteria (PEC) values for Nanofluid (NF) flow in different channel types are compared. It is observed that PEC values up to $Re=1500$ provide results deemed suitable for industrial applications. However, a realistic assessment indicates that channels with wave ratios of 4 and 5 are not preferred at $Re=2000$. Interestingly, the most stable and balanced situation is observed for Wavy Taped Tubes (WT) with a wave ratio of 6. This suggests that the WT with a wave ratio of 6 offers the most favorable performance in terms of both stability and efficiency across varying Reynolds numbers. It can be seen that the results are in good agreement with the results obtained in CFD and ANN approach. When the ANN results are analyzed, a deviation of 6.42% is observed when we compare the PEC results obtained in the ANN approach with the PEC results obtained with CFD. It is seen that the increase in the error rate is caused by the results at $y=5$ wave ratio.

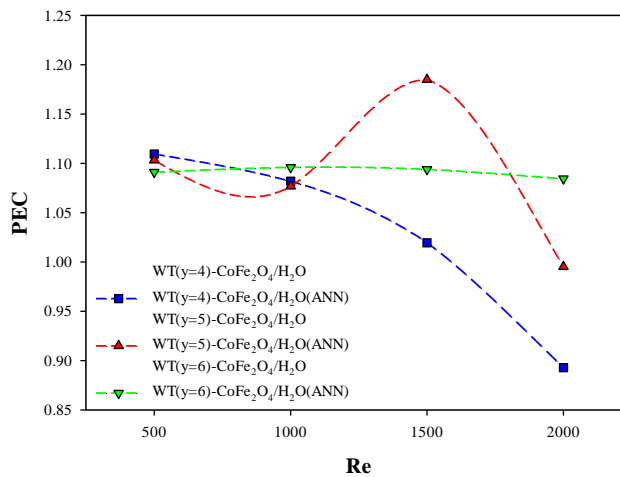

Fig. 11 Varying PEC for nanofluid

V. CONCLUSION

In an endeavor to understand the influence on forced convective heat transfer, friction coefficient, and entropy production within channel domains containing either water or a $CoFe_2O_4/H_2O$ nanofluid, this study employs numerical analyses utilizing the Finite Volume Method (FVM). Notably, what sets this investigation apart is its comprehensive examination of the $CoFe_2O_4/H_2O$ nanofluid, featuring a 1% volume fraction, alongside wave tape inserts with distinct wave ratios of 4, 5, and 6. This holistic approach aims to provide a thorough understanding of the combined effects of nanofluid properties and

wavy tape geometries on heat transfer characteristics and fluid dynamics within the channel. The following conclusions can be drawn from the present investigation:

- It has been determined that the wave ratio of the wavy tape insert, the type of working fluid, and the Reynolds number exert significant influence on both the Nusselt number and the friction coefficient.
- The case with the highest average Nusselt number and Performance Evaluation Criteria (PEC) values is observed for the Wavy Taped Tube (WT) with a wave ratio of 6, particularly under the flow of $\text{CoFe}_2\text{O}_4/\text{H}_2\text{O}$, across varying Reynolds numbers.
- All ANNs considered show accurate predictions except for some errors. The errors are seen in the smooth tube and $y=5$ wavelength predictions.

REFERENCES

- [1] H. Naik, S. Tiwari, Thermal performance analysis of fin-tube heat exchanger with staggered tube arrangement in presence of rectangular winglet pairs, *International Journal of Thermal Sciences* 161 (2021) 106723. <https://doi.org/10.1016/J.IJTHERMALSCI.2020.106723>.
- [2] M.R. Ali, K. Al-Khaled, M. Hussain, T. Labidi, S.U. Khan, L. Kolsi, R. Sadat, Effect of design parameters on passive control of heat transfer enhancement phenomenon in heat exchangers—A brief review, *Case Studies in Thermal Engineering* 43 (2023) 102674. <https://doi.org/10.1016/J.CSITE.2022.102674>.
- [3] W.X. Chu, C.A. Tsai, B.H. Lee, K.Y. Cheng, C.C. Wang, Experimental investigation on heat transfer enhancement with twisted tape having various V-cut configurations, *Appl Therm Eng* 172 (2020) 115148. <https://doi.org/10.1016/J.APPLTHERMALENG.2020.115148>.
- [4] A.T. Wijayanta, Mirmanto, M. Aziz, Heat transfer augmentation of internal flow using twisted tape insert in turbulent flow, *Heat Transfer Engineering* 41 (2020) 1288–1300. <https://doi.org/10.1080/01457632.2019.1637149>.
- [5] B. Kumar, A.K. Patil, S. Jain, M. Kumar, Effects of Double V Cuts in Perforated Twisted Tape Insert: An Experimental Study, *Heat Transfer Engineering* 41 (2020) 1473–1484. <https://doi.org/10.1080/01457632.2019.1649926>.
- [6] M. Rahimi, S.R. Shabani, A.A. Alsairafi, Experimental and CFD studies on heat transfer and friction factor characteristics of a tube equipped with modified twisted tape inserts, *Chemical Engineering and Processing: Process Intensification* 48 (2009) 762–770. <https://doi.org/10.1016/J.CEP.2008.09.007>.
- [7] M.E. Nakhchi, J.A. Esfahani, Numerical investigation of rectangular-cut twisted tape insert on performance improvement of heat exchangers, *International Journal of Thermal Sciences* 138 (2019) 75–83. <https://doi.org/10.1016/J.IJTHERMALSCI.2018.12.039>.
- [8] A. Ramadhan Al-Obaidi, I. Chaer, Study of the flow characteristics, pressure drop and augmentation of heat performance in a horizontal pipe with and without twisted tape inserts, *Case Studies in Thermal Engineering* 25 (2021) 100964. <https://doi.org/10.1016/J.CSITE.2021.100964>.
- [9] C. Tianpong, K. Wongcharee, H. Safikhani, S. Chokphoemphun, A. Sroysroy, S. Skullong, S. Eiamsa-ard, Multi objective optimization of $\text{TiO}_2/\text{water}$ nanofluid flow within a heat exchanger enhanced with loose-fit delta-wing twisted tape inserts, *International Journal of Thermal Sciences* 172 (2022) 107318. <https://doi.org/10.1016/J.IJTHERMALSCI.2021.107318>.
- [10] A. Kumar, S. Sharma, S. Kumar, R. Maithani, Thermohydraulic analysis of twisted tape inserts with $\text{SiO}_2/\text{H}_2\text{O}$ nanofluid in heat exchanger, *Australian Journal of Mechanical Engineering* 21 (2023) 1184–1197. <https://doi.org/10.1080/14484846.2021.1960672>.
- [11] Y. Ju, T. Zhu, R. Mashayekhi, H.I. Mohammed, A. Khan, P. Talebizadehsardari, W. Yaïci, Evaluation of Multiple Semi-Twisted Tape Inserts in a Heat Exchanger Pipe Using Al_2O_3 Nanofluid, *Nanomaterials* 2021, Vol. 11, Page 1570 11 (2021) 1570. <https://doi.org/10.3390/NANO11061570>.

- [12] T. Dagdevir, V. Ozceyhan, An experimental study on heat transfer enhancement and flow characteristics of a tube with plain, perforated and dimpled twisted tape inserts, *International Journal of Thermal Sciences* 159 (2021) 106564. <https://doi.org/10.1016/J.IJTHERMALSCI.2020.106564>.
- [13] R. Hosseinnezhad, O.A. Akbari, H. Hassanzadeh Afrouzi, M. Biglarian, A. Koveiti, D. Toghraie, Numerical study of turbulent nanofluid heat transfer in a tubular heat exchanger with twin twisted-tape inserts, *J Therm Anal Calorim* 132 (2018) 741–759. <https://doi.org/10.1007/S10973-017-6900-5/FIGURES/15>.
- [14] Y. Elmasry, R. Chaturvedi, E. Solomin, G.F. Smaisim, S.K. Hadrawi, The numerical investigation of a solar thermal collector with double-twisted tape insert absorber tube; the prediction of outlet temperature through a machine learning model, *Eng Anal Bound Elem* 161 (2024) 247–255. <https://doi.org/10.1016/J.ENGANABOUND.2024.01.015>.
- [15] J. Heeraman, R. Kumar, P.K. Chaurasiya, T.N. Verma, D.K. Chauhan, Optimisation and comparison of performance parameters of a double pipe heat exchanger with dimpled twisted tapes using CFD and ANN, <https://doi.org/10.1177/09544089231223599> (2024). <https://doi.org/10.1177/09544089231223599>.
- [16] S. Salimi, M.J. Mozoun, R. Beigzadeh, Heat transfer enhancement of serpentine channels with twisted tape insert by computational fluid dynamics and artificial intelligence, *Can J Chem Eng* 102 (2024) 1322–1340. <https://doi.org/10.1002/CJCE.25108>.
- [17] E. Ayli, E. Kocak, Prediction of the heat transfer performance of twisted tape inserts by using artificial neural networks, *Journal of Mechanical Science and Technology* 36 (2022) 4849–4858. <https://doi.org/10.1007/S12206-022-0843-X/METRICS>.
- [18] M.Z.A. Khan, M. Aziz, A.T. Wijayanta, Prediction of heat transfer enhancement of delta-wing tape inserts using artificial neural network, *Case Studies in Thermal Engineering* 27 (2021) 101322. <https://doi.org/10.1016/J.CSITE.2021.101322>.



An overview of using artificial neural networks to determine the behavior of steel beam-column connections

BOUBEKRI Amel¹, RAS Abdelouahab² BOUMECHRA Nadir³

¹Civil engineering, Abou Bekr Belkaid University, Tlemcen, Algeria

² Civil engineering, Abou Bekr Belkaid University, Tlemcen, Algeria

³ Civil engineering, Abou Bekr Belkaid University, Tlemcen, Algeria

¹ boubekriamel40@gmail.com

Abstract –The column-beam connections are important elements in the design and construction of steel structures. Their behavior is characterized by strength, stiffness, and stability, which must be reliably produced to represent the real behavior of a structure, especially when considering dynamic or seismic loading. Therefore, this article presents the results of a scientific review on the use of artificial neural networks to predict the strength and initial stiffness of steel column-beam connections. Different types of assemblies have been studied under monotonic and cyclic loading. The neural network results proved to be consistent with experimental and design code reference values.

Keywords – Steel Structures, Beam-To-Column Connections, Artificial Neural Networks, Joint Stiffness, Hysteretic Behavior

I. INTRODUCTION

Steel beam-column joints have been widely used in structures to ensure continuity between elements.

Traditionally, joints are considered either rigid or pinned. However, in reality, the most flexible joints are capable of transmitting a certain bending moment, while the stiffer joints allow for relative rotation of the assembled parts. Recognizing this reality led to the introduction of the concept of semi-rigidity in structural analysis. This concept, which aims to approximate the actual behavior of joints in structural analysis, offers great flexibility in the selection and sizing of joints. The behavior of an assembly is characterized by the Moment-Rotation law, and three characteristics are commonly used to describe this behavior: initial stiffness $S_{j,int}$ resisting moment $M_{j,Rd}$, and rotation capacity Φ . Fig.1.

After the Northridge earthquake in 1994 and the Kobe earthquake in 1995, extensive experimental and analytical studies [1], [2] were undertaken to investigate the feasibility of using bolted connections in frames for seismic resistance in

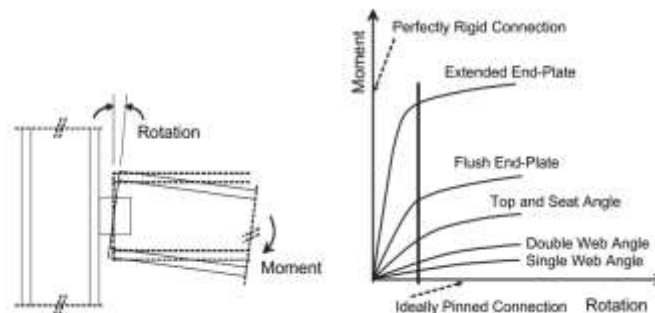

Fig.1. Typical moment-rotation curve of various connection types [3].

frames for seismic resistance in high-seismicity areas. Past research has demonstrated that semi-rigid connections can be effectively utilized for seismic design; however, the spectrum of their behaviour strongly influences the stability and strength of frames. To take advantage of semi-rigid connections, it is necessary to accurately represent the real hysteresis behaviour of the joint in analytical assessment and design analysis. Most modelling approaches are based on well-established fundamental mechanical theories using material and geometric properties. On the other hand, informative approaches have been used in several applications and have shown real potential as alternatives to mechanical approaches by directly extracting a hysteresis relationship from available data using a neural network or other optimization techniques.

II. MATERIALS AND METHOD

Various parameters contribute to characterizing the behavior ($M-\Phi$) of bolted connections, as shown in Fig. 2. Therefore, it is necessary to use reliable modeling techniques. In addition to experimental tests, three different modeling options are presented in the form of analytical or empirical models, advanced finite element models and component mechanical models. Among the multitude of research studies conducted on beam-column connections with end plates or with angles, traditional experimental or numerical methods are used in most cases.

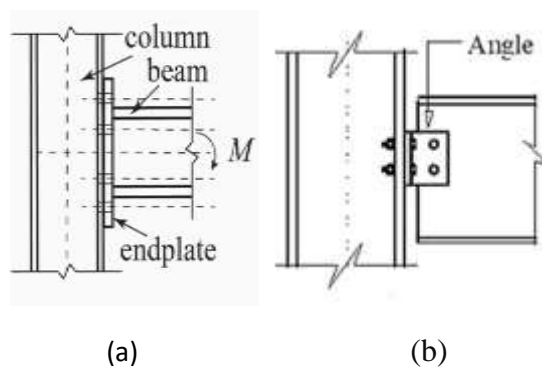

Fig. 2 Beam-column connection: (a) with end plate, (b) with angle.

This work is based on a review of the application of artificial neural network (ANN) techniques for the analysis of this type of connection.

ANNs are widely used to solve complex problems in civil engineering (and other fields), and their application has significantly increased in recent years. ANNs can be effectively applied for predictive modeling in various engineering domains, especially in cases where prior analyses (experimental or numerical) are already available. The origins of ANNs can be traced back to biology, where the biological brain is composed of billions of highly interconnected neurons forming a neural network.

III. ANN IN CIVIL ENGINEERING

Since the early 1990s, modeling methods based on artificial neural networks (ANNs) have been widely explored and applied in various fields.

In the field of civil engineering in particular, these approaches have been used for predicting structural behavior [4], [5], soil mechanics and geotechnical works [6], modeling concrete strength [7], [8], seismic applications [9], studies on pavement coatings [10], as well as for predicting bridge movement.

IV. ANN IN THE FIELD OF STEEL JOINTS

In recent years, promising progress has been made in the use of artificial neural networks (ANNs) in the field of steel connections.

Abdala and Stavroulakis [11] used a backpropagation neural network to estimate the behavior of semi-rigid steel connections, considering different types of connections such as angle connections and end plate connections, with three input parameters (number of bolts, length, and thickness of the angle).

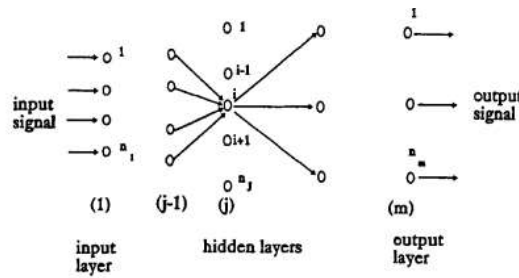

Fig. 3 Backpropagation learning, feedforward neural network [11]

Anderson et al. [12], applied ANN to predict the behavior of steel connections along the minor axis, showing acceptable accuracy but with approximately 19% misclassification for determining $M_{j,Rd}$, and a difference of 14.3% for Φ .

Lima et al.[13] employed a backpropagation ANN approach on 26, 34, and 18 specimens, respectively using end plate, welded, and angle configurations. Two neural networks were used for each type of connection: the first was used to predict the bending moment resistance, while the second was used to predict the stiffness of the connection. The input parameters included geometric and mechanical characteristics Fig.4. They demonstrated that for different types of connection configurations, the prediction performance for initial stiffness exhibited notably larger discrepancies compared to bending moment resistance, with variances of up to 59% from experimental results.

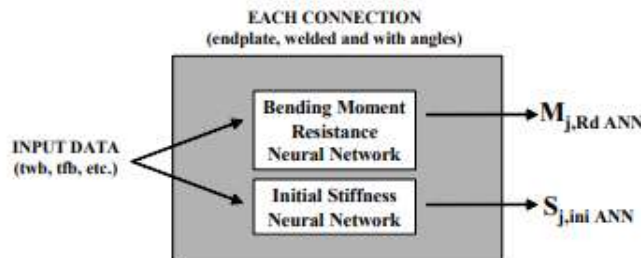

Fig. 4 Neural network configurations [13].

G. J. Yun et al. [14] proposed a self-learning simulation based on an auto-progressive algorithm to train a neural network model to learn the cyclic behaviour of beam-column connections with angles from analytically generated data and experimental data from the measured force-displacement response of the structure. It is reported that the proposed model demonstrates good ability to predict hysteretic responses.

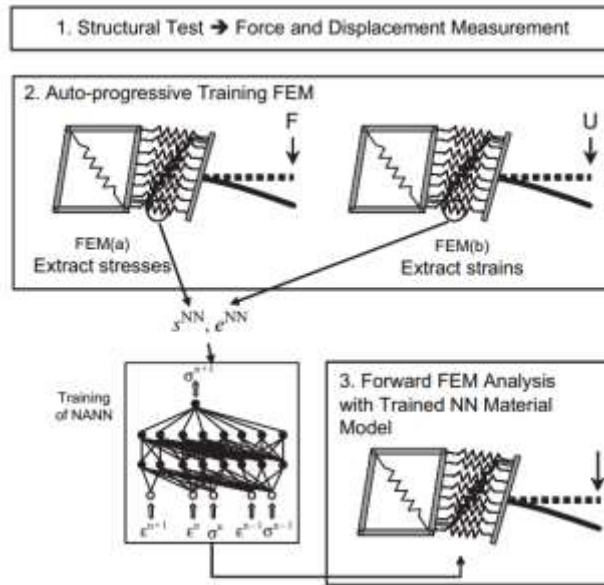

Fig. 5 Procedure of self-learning simulation based on auto-progressive algorithm. [14]

A study aimed to characterize the hysteretic response of a beam-column connection with end plate by Gholamzera et al.[15] using a neural network. The authors demonstrated that the proposed model is capable of estimating the initial stiffness, rotation capacity, and overall behavior, characterizing pinching effects, energy absorption, and ultimate strength. However, it is not able to distinguish the separate contribution of each component in the overall response of the assembly.

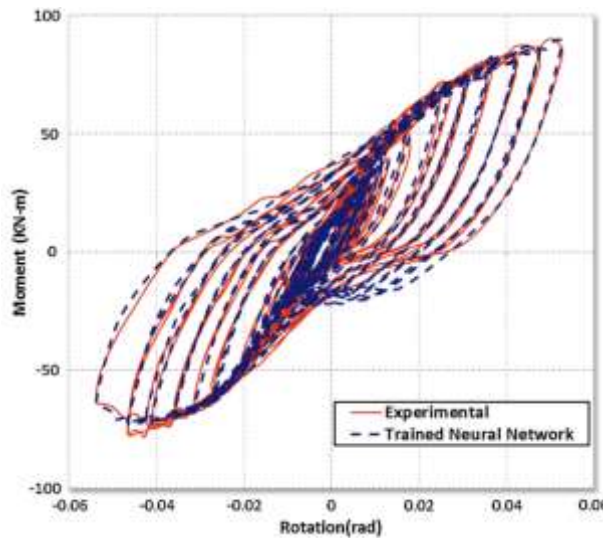

Fig. 6 Comparison of experimental results and NN model [15]

A. B. H. Kueh [16], proposes explicit expressions for predicting M_{max} and S_j using artificial neural network (ANN) and multiple linear regression (MLR) approaches, characterized by a simplistic input parameter insertion in terms of geometric characteristics of the assembled elements and mechanical properties of the bolt. The results show that both approaches are highly reliable in predicting the $(M- \Phi)$ relationship.

V. CONCLUSION

According to this review, it is evident that Artificial Neural Networks (ANNs) have been effectively utilized in various areas of construction engineering, particularly for predicting the behaviour of assemblies. In many situations in civil engineering, problems are complex and, making traditional mathematical modelling ineffective for simulating their behaviour. ANNs, on the other hand, rely solely on input-output

data for their training, making them suitable for solving complex problems. Additionally, they can be continuously improved by incorporating new training examples as new data becomes available. Thus, ANNs offer several significant advantages that make them a powerful and practical tool for addressing many challenges in the field of construction engineering, and their use is likely to expand in the future.

REFERENCES

- [1] A. S. Elnashai, A. Y. Elghazouli, and F. A. Denesh-Ashtiani. "Response of semirigid steel frames to cyclic and earthquake loads." *Journal of structural Engineering* 124.8 (1998): 857-867.
- [2] K. Takanashi, et al. "Earthquake behaviour of steel and composite frames." *University of Tokyo, Japan, Department of civil engineering, Imperial College, University of London* (1993).
- [3] S. L. Chan, and P. T. Chui, eds. *Non-linear static and cyclic analysis of steel frames with semi-rigid connections*. Elsevier, 2000.
- [4] M. Koçer, M. Öztürk, and M. Hakan Arslan. "Determination of moment, shear and ductility capacities of spiral columns using an artificial neural network." *Journal of Building Engineering* 26 (2019): 100878.
- [5] M. Z. Naser, S. Thai, and H. T. Thai. "Evaluating structural response of concrete-filled steel tubular columns through machine learning." *Journal of Building Engineering* 34 (2021): 101888.
- [6] S. K. Das, B. Manna, and D. K. Baidya. "Prediction of the dynamic soil-pile interaction under coupled vibration using artificial neural network approach." *Geo-Frontiers 2011: Advances in Geotechnical Engineering*. 2011. 1-10.
- [7] M. M. Alshihri, A. M. Azmy, and M. S. El-Bisy. "Neural networks for predicting compressive strength of structural light weight concrete." *Construction and Building Materials* 23.6 (2009): 2214-2219.
- [8] Y. Aggarwal, and P. Aggarwal. "Prediction of compressive strength of SCC containing bottom ash using artificial neural networks." *International Journal of Mathematical and Computational Sciences* 5.5 (2011): 762-767.
- [9] R. A. Hernandez-Becerril, "Seismic Alert System based on Artificial Neural Networks." *International Journal of Geological and Environmental Engineering* 6.6 (2012): 342-347.
- [10] H. S. Yoo, and Y. S. Kim. "Development of a crack recognition algorithm from non-routed pavement images using artificial neural network and binary logistic regression." *KSCE Journal of Civil Engineering* 20 (2016): 1151-1162.
- [11] K. M. Abdalla, and G. E. Stavroulakis. "A backpropagation neural network model for semi-rigid steel connections." *Computer-Aided Civil and Infrastructure Engineering* 10.2 (1995): 77-87.
- [12] D. Anderson, et al. "Application of artificial neural networks to the prediction of minor axis steel connections." *Computers & Structures* 63.4 (1997): 685-692.
- [13] L. R. O. De Lima, et al. "Neural networks assessment of beam-to-column joints." *Journal of the Brazilian Society of Mechanical Sciences and Engineering* 27 (2005): 314-324.
- [14] G. J. Yun, J. Ghaboussi, and A. S. Elnashai. "Development of neural network based hysteretic models for steel beam-column connections through self-learning simulation." *Journal of Earthquake Engineering* 11.3 (2007): 453-467.
- [15] A. Gholamreza, et al. "Determination of hysteretic behavior of steel end-plate beam-to-column connection with mechanical and neural network modeling." *Arabian Journal for Science and Engineering* 39 (2014): 7661-7671.
- [16] A. B. H. Kueh, "Artificial neural network and regressed beam-column connection explicit mathematical moment-rotation expressions." *Journal of Building Engineering* 43 (2021): 103195.



Elektrokardiyogram İşaretlerin Öz kodlayıcı Yöntemiyle Sıkıştırılması

Yücel KOÇYİĞİT^{1*}

¹Elektrik-Elektronik Müh. Bölümü /Manisa Celal Bayar Üniversitesi, Türkiye

*(yucel.kocyigit@cbu.edu.tr)

Özet – Elektrokardiyogram (EKG) işareti, temel olarak kalbin elektriksel faaliyetine denk gelir. EKG işareti, literatürde çeşitli hedefler doğrultusunda, kalp anormalliklerini teşhis etme, kalp atım hızını belirleme gibi amaçlar için analiz edilmiş ve kullanılmıştır. Ayrıca uzun süreli kalp ritmini takip etmek için Holter cihazları ile EKG işaretlerinin kayıt altına alınması gerekmektedir. Ancak uzun izleme süreleri, saklanması ve iletilmesi zor olan büyük miktarda veri üretir. Bu çalışmada EKG işaretlerine ait bilgileri kaybetmeden verilerin öz kodlayıcı yöntemiyle sıkıştırılması analiz edilmiştir.

Anahtar Kelimeler – Elektrokardiyogram, Segmentasyon, Öz kodlayıcı, Veri Sıkıştırma

I. GİRİŞ

Elektrokardiyogram (EKG), insan kalp aktivitesi hakkında bilgi sağlar ve kalbe ait hastalıklar esas olarak EKG ile izlenmektedir. Non-invaziv ve uygun maliyetli yapısı nedeniyle tıbbi kurumlarda yaygın olarak kullanılmaktadır. Sağlık hizmetlerinde giyilebilir EKG tespit sistemlerinin hızlı gelişimi, EKG işaretlerinin saklanması ve iletilmesi ihtiyacını artırmıştır. Holter cihazlarında olduğu gibi uzun süreli EKG işareti tespiti, çok büyük miktarda veri oluşturacaktır. Tipik olarak bu cihazlar, EKG veri aktarımı için kablosuz teknolojiyi kullanır ve bu da büyük veri hacimlerinin gerçek zamanlı aktarımında zorluk oluşturur.

EKG işareti veri aktarımından önce sıkıştırılarak bu sorun çözülebilir; bunun sonucunda iletilen veri miktarı azaltılırken teşhis ve tedaviye yönelik bilginin etkisi korunur. Bu nedenle verimli bir sıkıştırma teknolojisinin seçilmesi kritik öneme sahiptir. Literatürde EKG işaretlerinin sıkıştırılması için çeşitli yöntemler kullanılmıştır: Karhunen-Loeve Dönüşümü (KLD) [1], Fourier Tabanlı Dönüşüm (FTD) yöntemi [2], Ayrık Kosinüs Dönüşüm (AKD) yöntemi [3], Dalgacık Tabanlı Dönüşüm (DTD) yöntemi [4].

Bu çalışmada öz kodlayıcı yönteminin sıkıştırma amaçlı EKG işaretlerine uygulanması ele alınmıştır. Hedef, içerdiği bilgileri kaybetmeden (düşük hatayla) EKG işaret verilerinin yüksek oranda öz kodlayıcı yöntemiyle sıkıştırılmasıdır.

II. MATERYAL VE YÖNTEM

A. VERİ SETİ

Bu çalışmada, PhysioNet veri tabanında normal sinüs ritmi olan kişilere ait 15 adet EKG kaydı kullanıldı [5,6] (Şekil 1).

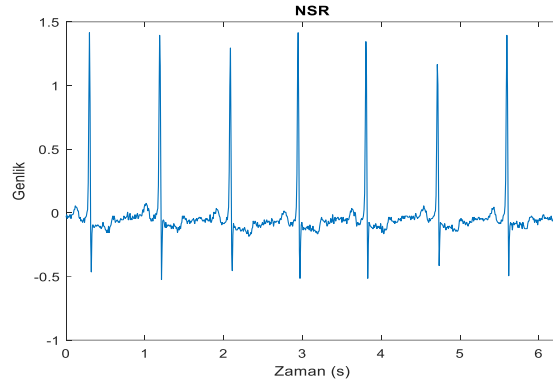

Şekil 1. NSR'ye ait EKG kayıtları

B. SEGMENTASYON

Normal sinüs ritmine ait EKG verileri Pan-Tompkins [7] algoritması kullanılarak RR aralıklarına ait veriler elde edildi (Şekil 2). Her QRS kompleksine ait R tepesi temel alınarak P dalgası ve T tepesini içerecek şekilde EKG kayıtları parçalara ayrıldı.

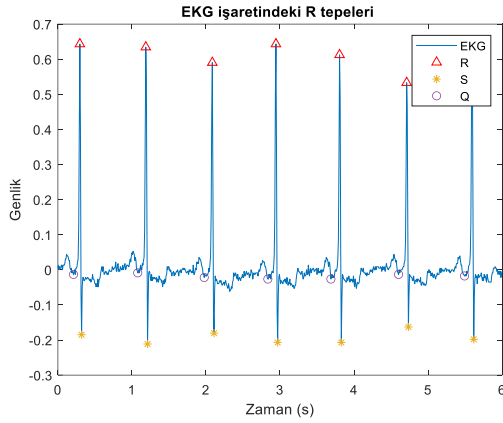

Şekil 2. Pan-Thompkins algoritması ile EKG işaretinde tespit edilen R tepeleri

C. ÖZ KODLAYICI (AUTO ENCODER) YÖNTEMİ

Öz kodlayıcı, girdi verilerini temel özelliklerine kadar verimli bir şekilde sıkıştırmak (kodlamak) ve ardından bu sıkıştırılmış gösterimden orijinal girdiyi yeniden oluşturmak (kodunu çözmek) için tasarlanmış bir tür sinir ağı mimarisidir.

Bir Öz kodlayıcı oluşturmak için iki bölüm gereklidir (Şekil 3). İlk bölüm "Kodlayıcı" olarak adlandırılır. Giriş verilerinden doğru bir kodlama elde etmekten sorumludur. Bu kodlama, giriş verilerinin daha küçük bir versiyonu olan sıkıştırılmış bir bilgi türüdür. Kodlama, bu verileri yeniden oluşturmak için kullanılabilir. Aslında, girdi verilerini çoğaltmak, Öz Kodlayıcının ikinci bölümünün öğrendiği şeydir. Bu kısma "Kod Çözücü" denir. Kod çözücü, aynı Öz Kodlayıcının girişine benzer bir Öz Kodlayıcının çıktısı oluşturmak için kodlamayı kullanır [8].

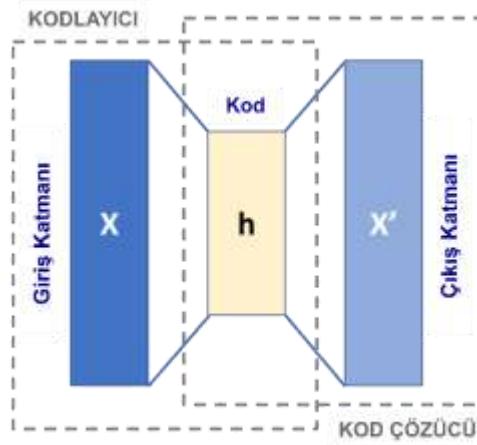

Şekil 3. Öz kodlayıcıya ait yapı [9]

Öz kodlayıcı verileri yeniden oluştururken Denklem 1’de verilen kayıp (loss) fonksiyonunu kullanır. x' çıkışını, x girişine yaklaştırmak ve kayıp fonksiyonunu küçültmek için yapay sinir ağlarındaki gibi ağırlıkları (W) dereceli günceller.

$$\mathcal{L}(x, x') = \|x - x'\|^2 \quad (1)$$

Denklem 2 ve Denklem 3, x' ve h 'yi elde etmek için kullanılan formüllerdir. Bu denklemlerle gizli katmandaki h değerleri ve bunları kullanarak çıkış katmanındaki x' değerleri bulunur. Denklemdeki σ , ileri beslemeli sinir ağlarındaki gibi aktivasyon fonksiyonunu temsil etmektedir.

$$h = \sigma(Wx + b) \quad (2)$$

$$x' = \sigma'(W'h + b') \quad (3)$$

D. PERFORMANS DEĞERLENDİRMESİ

Literatürde yaygın olarak kullanılan değerlendirme kriterleri, önerilen EKG sıkıştırma yaklaşımının sıkıştırma verimliliğini ve yeniden oluşturulan sinyallerin kalitesini belirlemek için kullanılmıştır. Bu performans ölçümleri aşağıdaki gibidir: (1) sıkıştırma oranı (CR); (2) ortalama karesel hatanın karekökü (RMS); (3) yüzde RMS farkı (PRD)[10]

Sıkıştırma Oranı (CR): Orijinal sinyali içeren dosyanın boyutu ile yeniden yapılandırılmış sinyali içeren dosyanın boyutu arasındaki, Denklem 4 ile hesaplanan oranı temsil eder.

$$R = \frac{D_{or}}{D_{re}} \quad (4)$$

Burada D_{or} orijinal sinyalin boyutunu, D_{re} ise yeniden oluşturulan sinyalin toplam boyutunu temsil eder.

Ortalama Karesel Hatanın Karekökü (RMS): Bir model tarafından tahmin edilen çıktı ile gerçek çıktı arasındaki varyansın belirlenmesinde yaygın olarak kullanılan bir yöntemdir. Bu çalışmada Denklem 5, burada S_o orijinal giriş sinyalini ve S_r ise orijinal giriş sinyalini temsil eder. Yeniden yapılandırılmış sinyal, RMS bu iki değer arasındaki varyansı hesaplamak için kullanılır.

$$RMS = \sqrt{\frac{\sum_{i=0}^{D-1} (S_o(i) - S_r(i))^2}{D-1}} \quad (5)$$

Yüzde RMS Farkı (PRD): Sıkıştırma yeniden oluşturulan verilerin kalitesini hesaplamak için kullanılan, yaygın olarak kullanılan bir performans ölçüsüdür. Kaliteli bir sıkıştırma yaklaşımı için PRD değerinin mümkün olduğu kadar düşük olması beklenir.

$$PRD(\%) = 100 * \sqrt{\frac{\sum_{i=0}^{D-1} (S_o(i) - S_r(i))^2}{\sum_{i=0}^{D-1} (S_o(i))^2}} \quad (6)$$

III. BULGULAR

Bu çalışmada EKG işaretlerine ait bilgileri kaybetmeden verilerin öz kodlayıcı yöntemiyle sıkıştırılması amaçlanmıştır. Bu amaçla PhysioNet veri tabanından alınan 15 adet EKG kaydı kullanıldı [5]. Bu kayıtlar eğitim ve test aşamalarında kullanılmak üzere sırasıyla %70-%30 oranında ayrıldı.

Öncelikle her bir ham EKG kaydı, Pan-Thompkins algoritması ile segmentasyon işlemine tabi tutuldu ve R tepeleri tespit edildi. 128 Hz örnekleme frekansına bağlı olarak R tepesi öncesi 30 ve sonrası 40 katsayı olmak üzere P dalgasını ve T tepesini içeren 71 katsayıdan oluşan toplam 10272 adet tek atım EKG örnekleri elde edildi. Normal sinüs ritmine (NSR) ait bu örneklerin 7191 adet örneği eğitim aşamasında; 3081 adet örneği test aşamasında kullanıldı.

Çalışmanın temel yaklaşımı, Pan-Thompkins algoritması ile yapılan segmentasyon sonucu tek atımlık EKG işaretlerini Öz kodlayıcının girişine uygulamak ve gizli katmandaki düğüm sayılarının miktarına göre boyut azaltmaktır; yani EKG işaretini sıkıştırmaktır. Ağın yapısı kodlayıcı ve kod çözücü olduğundan giriş uygulanan işaretler, aynı zamanda çıkış işaretlerini oluşturacaktır. Bu nedenle gizli katmandaki düğümler EKG bilgilerini içerecektir. Denenen farklı gizli düğüm sayılarına ait Sıkıştırma Oranı, Eğitim ve Test aşamalarındaki RMS ve PRD değerleri Tablo 1’de verilmiştir.

Öz kodlayıcı ağın eğitim ve test aşamalarında kullanılan EKG örneklerinin 5 ve 15 adet gizli düğüm için orijinal ve yeniden oluşturulan işaretleri sırasıyla Şekil 4 ve Şekil 5’te gösterilmiştir.

IV. TARTIŞMA

Öz kodlayıcı ağında giriş ile çıkış aynı olduğundan dolayı gizli katman çıkışlarının işaretlere ait öznelikleri taşıdığı; bir başka deyişle

Tablo 1. Eğitim ve test aşamalarındaki sıkıştırma oranları, RMS ve PRD değerleri

Gizli Düğüm sayısı	Sıkıştırma Oranı	Eğitim		Test	
		RMS	PRD(%)	RMS	PRD(%)
5	14,20	0,041	28,415	0,041	28,868
8	8,88	0,032	22,088	0,032	22,724
10	7,10	0,028	19,213	0,028	20,009
15	4,73	0,021	14,414	0,021	14,940
20	3,55	0,018	12,236	0,018	12,933

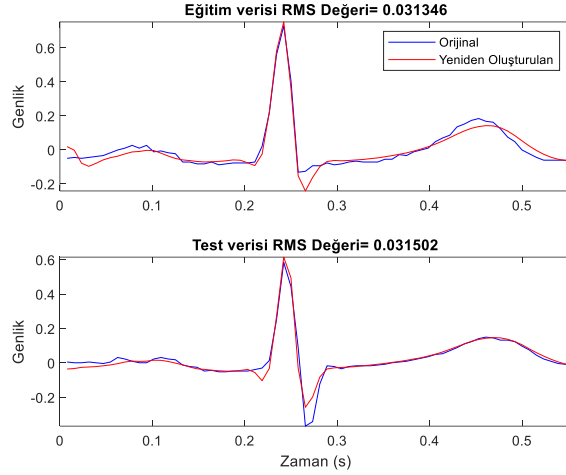

Şekil 4. Öz kodlayıcı ağı eğitim ve test aşamalarında kullanılan EKG örneklerinin 5 adet gizli düğüm için orijinal ve yeniden oluşturulan işaretleri

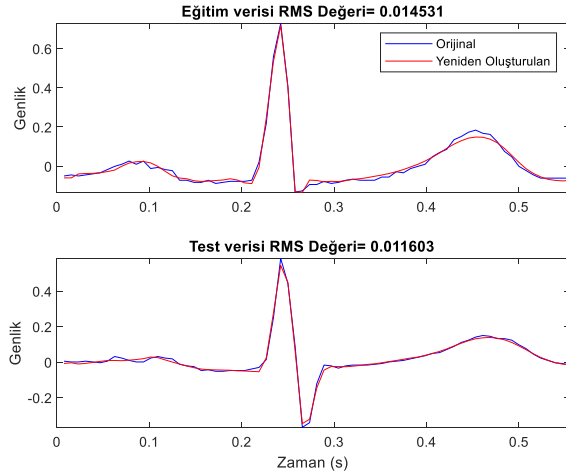

Şekil 5. Öz kodlayıcı ağı eğitim ve test aşamalarında kullanılan EKG örneklerinin 15 adet gizli düğüm için orijinal ve yeniden oluşturulan işaretleri

işaretin sıkıştırıldığı düşünülmüştür. Tablo 1. 'de görüldüğü gibi gizli katmanda kullanılan düğüm sayısına bağlı olarak sıkıştırma oranı değişmektedir. Farklı düğüm sayıları ile yapılan eğitimler ve test sonuçlarına göre sıkıştırma oranı arttıkça RMS ve PRD değerleri de artmaktadır. Örneğin, 5 gizli düğümüne sahip ağda oran 14,2 iken hata oranı 0,041 ve PRD %28,86 olmaktadır. Aynı şekilde 20 gizli düğüm için sıkıştırma oranı 3,55 gibi küçük bir değerde iken hata oranı 0,018 ve PRD değeri 12,93 bulunmuştur. İdeal durumda sıkıştırma oranının yüksek, hata ve PRD değerlerinin düşük olması istenir. Bu sonuçlar, literatürde elde edilen sonuçlara göre daha düşük başarılı çıkmıştır. Kullanılan EKG kayıtlarının örnekleme frekansının düşük olmasından dolayı ele alınan katsayı miktarının az olması ve buna bağlı olarak gizli düğüm sayısının daha düşük seçilememesi sıkıştırma oranını etkilemiştir. Hata oranlarının yüksek çıkması ise işarete herhangi bir ön işlem uygulanmamasından kaynaklı olabileceği düşünülmektedir. Diğer taraftan Şekil 4 ve Şekil 5'te görüldüğü gibi yeniden oluşturulan EKG örneğinde sapmalar olsa bile orijinal işareti büyük oranda temsil etmiştir; yani hata oranının yüksek olması EKG işaretindeki bilgilerin tam olarak kaybolduğu anlamına gelmemektedir.

V. SONUÇLAR

Bu çalışmada normal sinüs ritmine ait EKG kayıtlarının Pan-Tompkins algoritmasıyla segmente edilerek sıkıştırma amaçlı Derin Öğrenme algoritmalarından olan Öz kodlayıcı yöntemine uygulanması ele alınmıştır.

Bulunan sonuçlar literatürdeki diğer çalışmaların epey gerisinde kalmakla birlikte EKG kayıtlarına uygulanacak önışlemler sayesinde başarının daha yüksek olacağı düşünülmektedir.

KAYNAKLAR

- [1] Olmos S., Millan M., Garcia J., Laguna P., *ECG data compression with the Karhunen-Loeve transform*, Computers in Cardiology, Indianapolis, ABD, 253-256, 8-11 Sept, 1996.
- [2] Reddy B.S., Murthy I.S.N., *ECG data compression using Fourier descriptors*, IEEE Trans. Biomed. Eng., (4), 428-434, 1986.
- [3] Benzid R., Messaoudi A., Boussaad A., *Constrained ECG compression algorithm using the block-based discrete cosine transform*, Digital Signal Process., 18 (1), 56-64, 2008
- [4] Shinde A.A., Kanjalkar P., *The comparison of different transform based methods for ECG data compression*, Int. Conf., ICSCCN-IEEE, Thuckafay, India, 332-335, 21-22 June, 2011.
- [5] Wayne King (2023) mathworks/physionet_ECG_data (https://github.com/mathworks/physionet_ECG_data), GitHub. Retrieved September 21, 2023.
- [6] S. Goldberger AL, Amaral LAN, Glass L, Hausdorff JM, Ivanov PCh, Mark RG, Mietus JE, Moody GB, Peng C-K, Stanley HE. PhysioBank, PhysioToolkit, and PhysioNet: Components of a New Research Resource for Complex Physiologic Signals. *Circulation*. Vol. 101, No. 23, 13 June 2000, pp. e215-e220.
- [7] Pan, J., & Tompkins, W. J. (1985). *A real-time QRS detection algorithm*. IEEE transactions on biomedical engineering, (3), 230-236.
- [8] Sellat, Q., Bisoy, S. K., & Priyadarshini, R. (2022). *Semantic segmentation for self-driving cars using deep learning: a survey*. In Cognitive Big Data Intelligence with a Metaheuristic Approach (pp. 211-238). Academic Press.
- [9] The wikipedia website. [Online]. Available <https://en.wikipedia.org/wiki/Autoencoder>.
- [10] Yildirim, O., San Tan, R., & Acharya, U. R. (2018). *An efficient compression of ECG signals using deep convolutional autoencoders*. Cognitive Systems Research, 52, 198-211.



Artificial Intelligence and Its Use in Civil Engineering

Rachid RABEHI^{1,*}, Mohamed RABEHI², Mohammed OMRANE³, Said ZAOUAI⁴, Ahmed Rafik BELAKHDAR⁵ and Mohamed AMIEUR⁶

¹Laboratory (LDMM), Civil Engineering Department, University of Djelfa, Algeria

²Civil engineering and sustainable development laboratory, Ziane Achour University of Djelfa, 17000, Algeria

³Applied Automation and Industrial Diagnostic Laboratory, University of Djelfa, Algeria

⁴Laboratory of Eco-materials: Innovation & Applications (EMIA), Civil Engineering Department, University of Djelfa, Algeria

⁵Mining Laboratory, Department of Civil Engineering, Larbi Tebessi University, 12002, Tebessa, Algeria

⁶National School of Built and Ground Work Engineering, ENSTP, Alger, Algeria

**(rachid.rabehi@univ-djelfa.dz) Email of the corresponding author*

Abstract – Civil engineering stands to be revolutionized by artificial intelligence (AI) given mounting infrastructure demands from population growth and urbanization. AI's ability to process massive datasets allows it to enhance virtually every aspect of civil engineering projects. In design, generative AI algorithms can explore optimized solutions balancing factors like structural integrity, sustainability, and cost. During construction, AI enables automation through robotics, drones, and autonomous vehicles for tasks like surveying and material transportation. For infrastructure maintenance, AI-powered predictive analytics can monitor assets, detect anomalies, and forecast failures for preemptive fixes. However, challenges remain around data privacy, algorithmic bias, workforce training, and establishing ethical guidelines. Looking ahead, the convergence of AI with other emerging technologies like AR/VR, 3D printing, and blockchain promises to further revolutionize areas like smart city development, urban resilience, and sustainability. Overall, AI is poised to reshape civil engineering and infrastructure on a transformative scale.

Keywords – Civil engineering, Artificial Intelligence, Benefits of AI, Applications of AI.

I. INTRODUCTION

Civil engineering, often hailed as the cornerstone of modern infrastructure development, stands at the precipice of a transformative era, propelled by the rapid advancements in artificial intelligence (AI). As the global population burgeons and urbanization accelerates, the demand for innovative solutions to design, construct, maintain, and manage infrastructure grows exponentially. In this landscape, AI emerges as a formidable force, wielding its unparalleled capacity to ingest, analyze, and interpret colossal datasets, thereby orchestrating a paradigm shift across various realms of civil engineering [1-5].

At its core, AI represents a convergence of sophisticated algorithms, machine learning models, and computational prowess, imbued with the remarkable capability to emulate human-like cognitive functions. This capacity to discern patterns, extrapolate insights, and make autonomous decisions heralds a new era of efficiency, precision, and sustainability in civil engineering practices. From the inception of infrastructure projects through their lifecycle management, AI permeates every facet of the discipline, reshaping conventional methodologies and redefining industry standards [6-7].

In the realm of design and planning, AI algorithms harness the power of generative design and optimization techniques to explore an expansive design space, considering myriad parameters such as structural integrity, material efficiency, environmental impact, and cost-effectiveness. By iteratively

refining design iterations and simulating real-world scenarios, AI-driven design platforms yield solutions that transcend human capabilities, unlocking novel architectural forms and engineering marvels while minimizing resource consumption and ecological footprint [8].

Moreover, as construction sites evolve into dynamic ecosystems of activity and coordination, AI-driven automation emerges as a linchpin in streamlining operations and enhancing productivity [9-12]. Robotics, drones, and autonomous vehicles equipped with AI algorithms undertake a myriad of tasks, ranging from site surveying and excavation to material transportation and quality control, thereby mitigating labor-intensive processes, mitigating safety hazards, and accelerating project timelines [13-15].

Furthermore, in the realm of infrastructure maintenance and management, AI assumes the mantle of a sentinel, vigilantly monitoring the health and performance of critical assets, from bridges and highways to water treatment plants and utilities. Through an intricate network of sensors, IoT devices, and predictive analytics, AI systems scrutinize structural integrity, detect anomalies, and forecast potential failures, empowering engineers to preemptively address issues before they escalate into catastrophic events [16-18].

However, amidst the myriad promises and potentials of AI in civil engineering, a plethora of challenges loom large on the horizon. Concerns regarding data privacy, algorithmic bias, and ethical implications underscore the need for robust governance frameworks and ethical guidelines to ensure the responsible and equitable deployment of AI technologies. Additionally, the imperative for upskilling the workforce and fostering interdisciplinary collaboration between engineers, data scientists, and ethicists becomes paramount to harnessing the full potential of AI in the realm of civil engineering.

Looking ahead, the future implications of AI integration in civil engineering are both profound and far-reaching. As AI algorithms continue to evolve and mature, synergizing with emerging technologies such as augmented reality, 3D printing, and blockchain, the boundaries of what is conceivable within the realm of infrastructure development expand exponentially. Moreover, the advent of smart cities, underpinned by interconnected infrastructure systems and AI-enabled decision support systems, promises to usher in an era of unprecedented urban resilience, sustainability, and livability, thereby shaping the fabric of human civilization for generations to come.

II. MATERIALS AND METHOD

A. *Applications of AI in Civil Engineering*

1. Design Optimization

AI algorithms are being utilized to optimize the design process in civil engineering projects. By analyzing various parameters such as material strength, environmental factors, and cost constraints, AI can generate optimized designs that meet specific criteria, resulting in more efficient and sustainable structures.

2. Structural Health Monitoring

Monitoring the health of civil infrastructure is crucial for ensuring safety and longevity. AI-powered systems can analyze sensor data from structures such as bridges, dams, and buildings to detect signs of deterioration or potential failures. This early warning system enables proactive maintenance, reducing the risk of catastrophic incidents.

3. Construction Automation

AI-driven automation is streamlining construction processes, leading to increased efficiency and productivity. Robotics and autonomous vehicles equipped with AI capabilities can perform tasks such as excavation, material handling, and site inspection with precision and accuracy, reducing labor costs and project timelines [19-22].

4. Predictive Maintenance

Predictive maintenance leverages AI algorithms to anticipate equipment failures and schedule maintenance activities accordingly. In civil engineering, this approach is applied to infrastructure components like pipelines, roads, and utilities, optimizing maintenance schedules and minimizing downtime.

5. Traffic Management

AI-powered traffic management systems analyze real-time data from sensors, cameras, and GPS devices to optimize traffic flow and reduce congestion. By dynamically adjusting signal timings, rerouting vehicles, and providing predictive analytics, these systems enhance safety and efficiency on roads and highways.

B. Benefits of AI in Civil Engineering

- Efficiency: AI streamlines various processes, leading to faster project delivery and reduced costs.
- Safety: By detecting potential hazards and structural vulnerabilities, AI enhances safety in construction and maintenance activities.
- Sustainability: AI-driven design optimization promotes the use of eco-friendly materials and reduces environmental impact.
- Data-Driven Decision Making: AI enables informed decision-making by analyzing vast amounts of data and providing actionable insights.

C. Challenges and Future Implications

Despite its potential, the integration of AI in civil engineering poses several challenges, including data privacy concerns, ethical considerations, and the need for specialized skills among professionals. Additionally, ensuring the reliability and accuracy of AI systems remains a critical issue, especially in safety-critical applications.

Looking ahead, the future implications of AI in civil engineering are vast. Continued advancements in AI technologies, coupled with the increasing availability of data from sensors and IoT devices, will further enhance the capabilities of AI-driven systems. Moreover, AI has the potential to revolutionize urban planning and design, enabling the creation of smart cities with interconnected infrastructure systems that optimize resource utilization and improve quality of life.

III. CONCLUSION

Artificial intelligence is reshaping the landscape of civil engineering, offering unprecedented opportunities for innovation and efficiency. From design optimization and construction automation to predictive maintenance and traffic management, AI is transforming every aspect of the industry. While challenges remain, the continued advancement of AI technologies holds immense promise for the future of civil engineering, paving the way for safer, more sustainable, and resilient infrastructure worldwide.

REFERENCES

- [1] Rabehi, R., Rabehi, M., & Omrane, M. (2023, April). Steel fiber's effects on the physical and mechanical characteristics of self-compacting concrete (SCC) made of recycled gravel. In *International Conference on Scientific and Innovative Studies* (Vol. 1, No. 1, pp. 295-301). <https://doi.org/10.59287/icsis.616>
- [2] Rabehi, R., Rabehi, M., & Omrane, M. (2023). Physical-mechanical and fresh state properties of self-compacting concrete based on different types of gravel reinforced with steel fibers: Experimental study and modeling. *Construction and Building Materials*, 390, 131758. <https://doi.org/10.1016/j.conbuildmat.2023.131758>
- [3] Rabehi, R., Mohamed, R., & Mohammed, O. (2023). Study of the durability of self-compacting concrete made from recycled gravel. *The Journal of Engineering and Exact Sciences*, 9(4), 15927-01e. <https://doi.org/10.18540/jcecvl9iss4pp15927-01e>
- [4] Rabehi, R., Mohamed, A., Mohamed, R., & Mohammed, O. (2023). Effect of additions on the self-compacting concrete's absorption. *The Journal of Engineering and Exact Sciences*, 9(6), 16058-01e. <https://doi.org/10.18540/jcecvl9iss6pp16058-01e>
- [5] Lamine, B. A., Mohamed, A., & Rachid, R. (2023). Concrete reinforcement using composite fiberglass-based materials. *The Journal of Engineering and Exact Sciences*, 9(7), 16530-01e. <https://doi.org/10.18540/jcecvl9iss7pp16530-01e>
- [6] MESSAOUD, M., BOUAZZA, M., & RABEHI, R. (2023, June). Analytical modeling of the behavior of nano-plates by the theory of nonlocal elasticity. In *International Conference on Pioneer and Innovative Studies* (Vol. 1, pp. 455-461). <https://doi.org/10.59287/icpis.873>

- [7] RABEHI, R., AMIEUR, M., & RABEHI, M. (2023). Evaluation of self-compacting concretes (SCC) made with brick powder using non-destructive and destructive tests. *All Sciences Abstracts*, 1(5), 13-13. <https://doi.org/10.59287/as-abstracts.1432>
- [8] Rachid RABEHI, Mohamed RABEHI, Mohammed OMRANE, Said ZAOUAI and Mohamed AMIEUR. (2023). The role of fibers and mineral admixtures in self-compacting concrete. 4th International Conference on Engineering and Applied Natural Sciences. <https://doi.org/10.59287/as-proceedings.353>
- [9] Rachid RABEHI, Mohamed RABEHI, Mohammed OMRANE, Abdelkader FIDJAH, Ahmed Rafik BELAKHDAR and Mohamed AMIEUR. (2023). Analysis of the use of self-compacting concrete in Algeria: opportunities and challenges. 4th International Conference on Engineering and Applied Natural Sciences. <https://doi.org/10.59287/as-proceedings.313>
- [10] BENZERGA, A. L., AMIEUR, M., & RABEHI, R. (2023, May). Reinforcement of concrete with composite materials based on fiberglass. In *International Conference on Contemporary Academic Research* (Vol. 1, No. 1, pp. 42-47). <https://doi.org/10.59287/iccar.736>
- [11] RABEHI, R., AMIEUR, M., & RABEHI, M. (2023, May). Characterizations of self-consolidating concrete (SCC) from a physicalmechanical perspective with various additions. In *International Conference on Recent Academic Studies* (Vol. 1, pp. 58-63). <https://doi.org/10.59287/icras.672>
- [12] RABEHI, R., AMIEUR, M., & RABEHI, M. (2023, July). The effect of finely ground dune sand on the properties of self-compacting concrete. In *International Conference on Recent Academic Studies*. (2023, July). (Vol. 1, No. 1, pp. 984–988). <https://doi.org/10.59287/icaens.1120>
- [13] RABEHI, R., AMIEUR, M., & RABEHI, M. (2023). Evaluation of self-compacting concretes (SCC) made with brick powder using non-destructive and destructive tests. *All Sciences Abstracts*, 1(5), 13-13. <https://doi.org/10.59287/as-abstracts.1432>
- [14] RABEHI, R., OMRANE, M., BELAKHDAR, A. R., & AMIEUR, M. (2023). Crushed dune sand (cds) and superplasticizers effects on self-compacting concrete fresh properties. *AS-Proceedings*, 1(1), 27–30. <https://doi.org/10.59287/as-proceedings.29>
- [15] Abdelkader, F., Mohamed, R., Cheikh, K., & Rabehi, R. (2023). Mechanical properties of compressed earth blocks reinforced with glass fibers and palm fibers: Experiments and simulation. *The Journal of Engineering and Exact Sciences*, 9(5), 15916-01e. <https://doi.org/10.18540/jcecvl9iss5pp15916-01e>
- [16] Rabehi, M., Rabehi, R. (2021). Physico-mechanical Characterizations of the Compressed Earth Block (CEB) Stabilized with Lime-Based Fibers (Waste Tyre Rubber-Glass). In: Chiba, Y., Tlemçani, A., Smaili, A. (eds) *Advances in Green Energies and Materials Technology*. Springer Proceedings in Energy. Springer, Singapore. https://doi.org/10.1007/978-981-16-0378-5_6
- [17] Meymouna, M., Bachir, G., Othmane, A., & Rabehi, R. (2023). Contribution to the non-destructive evaluation of bituminous mixes by electrical measurements. *The Journal of Engineering and Exact Sciences*, 9(8), 16003-01eup. <https://doi.org/10.18540/jcecvl9iss8pp16003-01eup>
- [18] RABEHI, R., OMRANE, M., RABEHI, M., BELAKHDAR, A. R., DIMIA, M. S., & AMIEUR, M. (2023). Pozzolan (poz) effects on self-compacting concrete fresh properties. *AS-Proceedings*, 1(2), 490–493. <https://doi.org/10.59287/as-proceedings.232>
- [19] Rabehi, M. (2014). Apport à la caractérisation de la porosité ouverte du béton d'enrobage par l'utilisation des tests d'absorption capillaire (Doctoral dissertation, Université Mohamed Khider Biskra). <http://thesis.univ-biskra.dz/id/eprint/1172>.
- [20] RABEHI, R., RABEHI, M., OMRANE, M., ZAOUAI, S., & AMIEUR, M. (2023). Influence of recycled concrete gravel and sand in self-compacting concrete (SCC). *AS-Proceedings*, 1(6), 522-525. <https://doi.org/10.59287/as-proceedings.522>
- [21] MESSAOUD, M., GLAOU, B., ABDELKHALEK, O., & RABEHI, R. (2023). Electrical measurements' contribution to the non-destructive assessment of bituminous mixtures. *AS-Proceedings*, 1(1), 406–410. <https://doi.org/10.59287/as-proceedings.102>
- [22] Rabehi, R., & Amieur, M. R. E. M. Effet Des Ajouts Sur La Résistance A La Compression Et L'absorptiond'eaude Bétonautoplaçant (BAP). In 1st International Congress on Advances in Geotechnical Engineering and Construction Management (p. 853). https://www.researchgate.net/profile/Rabehi-Rachid/publication/371307573_VolumeII/links/647e5ff279a7223765137023/VolumeII.pdf#page=302.
- [23] Rachid, R., Mohamed, R., & Mohammed, O. Study of the durability of self-compacting concrete made from recycled gravel Estudo da durabilidade do concreto autoadensável de brita reciclada. <https://www.academia.edu/download/104359755/7994.pdf>.



Akıllı Kent Uygulamaları Kapsamında Coğrafi Bilgi Sistemleri Çalışmalarının İncelenmesi

Mahmud Zahid MUTLU, M. Hanefi CALP

Yönetim Bilişim Sistemleri / İktisadi ve İdari Bilimler Fakültesi, Ankara Hacı Bayram Veli Üniversitesi, Türkiye

mahmud.mutlu@hbv.edu.tr, hanefi.calp@hbv.edu.tr

Özet – Günümüzde giderek artan teknolojik gelişmeler, kentlerde artan istihdam açıkları, yeni sanayi kolları, bu durumlara paralel olarak gelişen çarpık kentleşme ve düzensiz göç durumları kent yaşamını ve kent yönetimini olumsuz etkilemektedir. Akıllı kent; bu olumsuzlukların getirdiği sorunlara çözüm arayan uygulamalardan birisidir. Akıllı kent uygulamaları aynı zamanda kent planlaması, sürdürülebilir kent planlaması, akıllı göç planlama gibi bir çok konuya dahil olup; Coğrafi Bilgi Sistemlerinin (CBS) mekânsal analiz ve raporlama yetenekleriyle optimum düzeyde entegre olabilmektedir. Bu bağlamda bu çalışma literatürdeki çalışmaları inceleyerek, akıllı kent uygulamalarının coğrafi bilgi sistemleri ile ilişkisinin incelemeyi ve bu ilişkileri oluşturan konuların ortaya çıkarılmasını amaçlamaktadır. Çalışma sonucunda akıllı kent planlaması ve sürdürülebilirlik üzerine daha çok yoğunlaşıldığı görülmüştür.

Anahtar Kelimeler – Coğrafi Bilgi Sistemleri, Akıllı Kent, Kentsel Planlama, Bilişim, Yönetim

I. GİRİŞ

Sanayi devrimi ve bir sonraki yüzyılda gerçekleşen II. Dünya Savaşı sonrasında hızlanan sanayileşme ve kentleşme, beraberinde birçok sosyolojik ve toplumsal sorunları da getirmiştir. Tarımsal ekonomiden sanayileşmeye doğru geçen bu süreçte; düzensiz göç hareketleri, kültürel değişimler, plansız yayılmalar ortaya çıkmıştır [1].

Düzensiz göç, çarpık kentleşme, altyapı yetersizliği, yanlış kent planlaması gibi sorunlara çözüm olması açısından bazı tanımlamalar ve uygulamalar ortaya çıkmıştır. Bunlara örnek olarak “akıllı kent”, “akıllı şehir”, “yetenekli kent”, “sürdürülebilir kent”, “dijital kent” tanımları literatürde yerini almıştır [2].

Akıllı kent kavramının çıkış noktası aslında tarih boyunca süregelen “ideal kent” yaklaşımını benimseyen ve buna yönelik ortaya çıkan çözümler olmuştur. Akıllı kent kavramı, kentin hem fiziksel hem de sosyal altyapısının kurumsal bakış açısıyla bir karışımı olarak nitelendirebiliriz. Sanayi devrimi sonrası modern kentleşmenin arttığı süreç içerisinde 1980 yıllarında gelişen kenti ağ yapılarıyla çevreleme düşüncesi ile altyapı ve ulaşım boyutunda yeni çözümler ortaya çıkmıştır [3],[4].

Tüm akıllı kentlerde olması gereken akıllı ulaşım, akıllı yaşam, akıllı yönetim gibi unsurlar coğrafi bilgi sistemlerinin getirdiği teknolojik imkanlar sayesinde kente uygun şekilde entegre edilebilir. Coğrafi bilgi sistemleri (CBS), konuma dayalı verileri inceleyerek, analiz ederek çözümler sunmaktadır. Kentlerde bulunan konuma dayalı veriler analiz edilerek CBS haritaları ortaya çıkar, bu haritalar sayesinde detaylı grafikler, raporlar, 3B kent modellemesi, önemli yapıların sayısal ikizi gibi birçok çözümler ortaya koyar. Coğrafi bilgi sistemleri bu sayede birey - kamu etkileşimini artırır, akıllı kentleşmenin çözüm sunduğu birçok alanda katkıda bulunur [5].

Bu çalışmanın amacı, literatürde yer alan akıllı kent uygulamalarının coğrafi bilgi sistemleri ile ilişkisinin incelenmesi ve bu ilişkileri oluşturan konuların ortaya çıkarılmasıdır.

Akıllı kent uygulamaları için Coğrafi bilgi sistemi teknolojilerinin kullanıldığı alanlara baktığımızda örnek olarak “kent güvenliği” ve “kent planlaması” alanlarından bahsedilebilir. Türkiye’deki akıllı kent uygulamalarının incelendiği, doğru kent planlaması ve buna paralel olarak oluşturulan kent güvenliği stratejilerin mevcut örneklerinin incelendiği çalışmada araştırmacılar CBS ve akıllı kent uygulamalarının entegre bir şekilde kent güvenliğine çözümler üretebildiğine dair sonuca varmıştır [6].

Bir diğer ilişkilendirme örneği olarak “erişilebilirlik” ve “destek sistemi” alanları üzerinde çıkarımlar yapılabilir. Herhangi bir lokasyona, herhangi bir kamu hizmetine ulaşılabilirliğin herkes tarafından olabilmesi erişilebilir bir kent aracılığı ile olabilir. CBS yazılımları aracılığıyla yapılan çalışmalarda Ankara ili özelinde mekânsal veri analizleri yapılmış, erişilebilirlik düzeyine ilişkin raporlar ortaya çıkarılmıştır. Çalışma sonucunda, mekânsal veri tabanı oluşturmanın, bir destek sistemi vasıtasıyla erişilebilir kent ve akıllı kent için önemi ortaya çıkmıştır [7], [8].

Bu ilişkilendirmelere bir diğer örnek olarak “sürdürülebilirlik” kavramı verilebilir. Araştırmacıların akıllı kent yaklaşımının insan hayatını, kent yaşantısını sürdürülebilir hale getirme noktasında önemli bir çözüm kaynağı olduğu vurguladığı çalışmada, İstanbul Büyükşehir Belediyesi’nin akıllı kent çalışmalarının Birleşmiş Milletler Sürdürülebilir Kalkınma Amaçları arasındaki ilişkisi incelenmiştir [9]. Sürdürülebilirlik ve CBS ilişkisi üzerine yapılan araştırmalar incelendiğinde kentsel planlama üzerine yapılan çalışmaların yoğunlukta olduğu görülmüştür [10]. Bu durum; akıllı kent uygulamalarının CBS ile entegre olarak sürdürülebilir kent planlaması için önemini belirtmek açısından önemlidir.

Coğrafi Bilgi Sistemleri (CBS) ve Akıllı Kent kavramlarının birlikte ele alındığı diğer konular ise “kentsel dönüşüm”, “sürdürülebilir kentsel dönüşüm” ve “akıllı kentsel dönüşüm” konularıdır. Özellikle sanayi devrimi sonrası üretim, sanayi, istihdam koşullarının arttığı kentler, işçiler için merkez haline gelmiştir. Bu süreçte yaşanan düzensiz göç hareketleri, plansız kentleşme durumları sebebiyle yaşam koşulları olumsuz yönde ilerlemiş, bu durumlara çözüm olarak yeni politikalar aranmaya başlanmıştır [11]. 2023 yılında yapılan bu çalışmada; araştırmacılar kentsel dönüşüm uygulamalarının tarihsel sürecini analiz etmiş, çalışma sonucunda kentsel dönüşüm süreçlerinin akıllı kent uygulamaları ve sürdürülebilir kent uygulamalarına entegre şekilde gerçekleşmesi sonucuna varmışlardır [12].

II. MATERYAL VE YÖNTEM

Araştırma literatür taraması yöntemiyle gerçekleştirilmiş, toplanılan veriler analiz edilmiştir. Veriler Scopus veri tabanından, belli kriterler uygulanarak elde edilmiştir. Kriter seçimi araştırmaya uygun nitelikte oluşturulmuş, arama sorgusunda; “CBS” ya da “Coğrafi Bilgi Sistemleri” ve “Akıllı kent” kavramlarının anahtar kelime olarak birlikte yer aldığı çalışmalar aratılmıştır. Arama kriterlerinde herhangi bir zamansal periyod belirtilmemiştir. Arama sonucunda 162 makale bulunmuştur.

Yapılan sorgular sonucunda elde edilen çalışmalar ayrı ayrı incelenmiş, çalışma amacına yönelik olarak analiz edilmiştir. Akıllı kent alanında çalışma yapan, aynı zamanda CBS teknolojileri de kullanılan çalışmalarda yapılan ilişkilendirmeler ortaya çıkarılmıştır. Analiz edilen çalışmalar 11 ana kategori olarak ayrılmış, kategoriler Çizelge 1 de verilmiştir.

Çizelge 1. Kategoriler

No	Kategoriler
1	3B Modelleme
2	Ulaşım
3	Otonom
4	Sürdürülebilirlik
5	Turizm
6	Yer Kullanımı - Yer Seçimi
7	Çevre - İklim
8	Destek Sistemi
9	Enerji
10	Yapay Zeka
11	Kent Planlaması

III. BULGULAR

Yapılan literatür taraması sonucu, anahtar kelimeleri “Smart City” ya da “Smart Cities” ve “Geographic Information System” kavramlarının bir arada geçtiği Scopus veri tabanındaki makaleler listelenmiştir.

11 ana kategoriye ayrılan çalışmalar, toplam çalışma sayılarına göre grafik halinde Şekil 1 de belirtilmiştir.



Şekil 1. Kategorilere Göre Araştırmaların Dağılımı

Yapılan çalışmalarda kent planlaması üzerine yoğunlaştığı görülmüştür. Bu sonucun çıkma sebebi, akıllı kent ve coğrafi bilgi sistemleri kavramlarının aslında kent planlaması üzerine yapılan stratejilere ve sorunlara başlıca çözüm bulucu olarak nitelendirilmesi gösterilebilir.

Çevre – iklim konusunun ikinci sırada görülmesi, günümüz dünyasının başlıca problemleri arasında yer alması sebebiyle şaşırtıcı olmamıştır. Akıllı kent uygulamaları ile iklim ve çevre sorunlarına çözüm aramak, mevcut uygulamaların bu sorunlara ne ölçüde faydalı olduğunu ölçmek gibi birçok alanda çalışmalar yapılmaktadır. B u çalışmalara devam ederek gelecekte dünya yaşamını bu başlıca problemden uzaklaştırmaya çalışmak araştırmacıların önemli amaçlarından olmaya devam edecektir.

Araştırmacıların ulaşım, 3B modelleme, yer seçimi gibi alanlarda yoğunlaşma sebebi olarak Coğrafi bilgi sistemlerinin mekânsal analiz ve raporlama yeteneği sayesinde akıllı kent uygulamalarına destek sağlaması gösterilebilir.

IV. SONUÇLAR

Bu çalışmada Akıllı Kent ve CBS kavramlarının entegre olarak ele alındığı araştırmalar incelenmiştir. Çalışma sonucunda araştırmacıların daha çok akıllı kent planlaması üzerine yoğunlaştığı görülmüştür.

Kentlerde hayatın daha yaşanabilir ve sürdürülebilir olması amacıyla yapılan çalışmaların odak noktası akıllı kent noktasında yoğunlaşmıştır. Günümüzde CBS teknolojilerinin gelişmesi, dünya genelinde yaygın kullanımıyla örneklerinin artması, akıllı kent planlamasında kullanımının önemini arttırmaktadır.

KAYNAKLAR

- [1] NİRAY, N. (2002). Tarihsel Süreç İçinde Kentleşme Olgusu ve Muğla Örneği. Muğla Üniversitesi Sosyal Bilimler Enstitüsü Dergisi(9), 1-27.
- [2] URL-1 (2016), The World Bank Annual Report 2016, <https://thedocs.worldbank.org/en/doc/596391540568499043-0340022018/original/worldbankannualreport2016.pdf>, [Erişim Tarihi:12.02.2024]
- [3] Mirghaemi, S. A. (2019). AKILLI KENTLER ÜZERİNE BİR İNCELEME: TÜRKİYE ÖRNEĞİ. Beykent Üniversitesi Fen Ve Mühendislik Bilimleri Dergisi, 12(2), 37–46. <https://doi.org/10.20854/bujse.628495>
- [4] JBATTY, M., AXHAUSEN, K. W., GIANNOTTI, F., POZDNOUKHOV, BAZZANI, A., WACHOW-ICS, M., OUZOUNIS, G., PORTUGALI, Y., (2012), “Smart cities of the future”. European Physical Journal Special Topics, 214(1), 481–518.
- [5] Seymen Aksu, N., & Yalçın Ercoşkun, Ö. (2022). Akıllı Kentlerin Geleceğinde Coğrafi Bilgi Sistemleri (CBS). Plant Dergisi, cilt.13, sa.41-42, ss.236-240, 2022.
- [6] ASLAN, M. M., & BULUT, Y. (2019). AKILLI KENT UYGULAMALARININ KENTSEL GÜVENLİK AÇISINDAN ÖNEMİ. ASSAM Uluslararası Hakemli Dergi52-60.
- [7] Keleş R. (1980). Kentbilim terimleri sözlüğü, Türk Dil Kurumu Yayınları, Ankara
- [8] ERÇETİN, C., DURMAZ, B., & AKSOY, Ç. (2022). Akıllı Kent, Erişilebilirlik ve Mekansal Veri Tabanı İlişkisi Üzerine Engeller Analizi: Ankara Örneği. İDEALKENT, 13(36), 487-518. <https://doi.org/10.31198/idealkent.1076597>
- [9] ÇAKICI, K., & KIZILBOĞA ÖZASLAN, R. (2021). Birleşmiş Milletler 2030 Sürdürülebilir Kalkınma Amaçlarının Akıllı Kent Uygulamalarındaki Karşılığı: İstanbul Büyükşehir Belediyesi Örneği. Gümüşhane Üniversitesi Sosyal Bilimler Dergisi, 12(2), 209-233. <https://doi.org/10.36362/gumus.829733>
- [10] Mutlu, M. E., & Calp, M. H. (2023). Sürdürülebilirlik kapsamında coğrafi bilgi sistemleri çalışmalarının incelenmesi. *International Conference on Applied Engineering and Natural Sciences*, 1(1), 831-837. <https://doi.org/10.59287/icaens.1102>
- [11] Şahin, S. Z. (2003). İmar planı değişiklikleri ve imar hakları aracılığıyla yanıltıcı (Pseudo) kentsel dönüşüm senaryoları: Ankara Altındağ ilçesi örneği. İçinde P. P. Özden (Ed.), *Kentsel dönüşüm sempozyumu: bildiriler* (ss. 89-101). İstanbul: TMMOB Şehir Plancıları Odası
- [12] ÇAKIR, E. (2023). 21. YÜZYILDA KENTSEL DÖNÜŞÜM VE YENİ EĞİLİMLER. Meriç Uluslararası Sosyal Ve Stratejik Araştırmalar Dergisi, 7(18), 118-144. <https://doi.org/10.54707/meric.1283846J>.



Exploring Large Language Models for clinical Named Entity Recognition – case of Albanian language

Elira Hoxha¹, Polina Çeço^{1*}

¹Department of Statistics and Applied Informatics/Faculty of Economy, University of Tirana, Albania

^{*}(polina.ceco@unitir.edu.al) Email of the corresponding author

Abstract – Natural Language Processing (NLP) has emerged as a pivotal discipline in sensemaking and exploiting the knowledge embedded in unstructured textual and speech data in various domains. This is the case especially for healthcare where a major part of the information on patients is in narrative form. Named Entity Recognition (NER) is acclaimed as the cornerstone task that help unlock the knowledge embedded in unstructured data. Even though advanced pre-trained Large Language Models (LLM) like BioBERT, ClinicalBERT or BlueBERT have achieved state-of-the-art results in clinical NER task, these models are not applicable to languages other than English. MultilingualBERT (mBERT) has emerged as a solution for low-resource languages as Albanian. The model is pre-trained in 104 languages and achieves satisfactory results in low-resource languages through zero-shot or few-shot cross-lingual model transfer. In this paper we advocate that an mBERT initialized model is the best strategy for producing a clinical NER solution in Albanian. We conclude that the creation of a biomedical corpora would potentially increase the performance of the main model, and gold standard annotated data would create a benchmark for the clinical NER endeavor in Albanian paving the way for future research in the field.

Keywords – Machine Learning, NLP, clinical NER, mBERT, Albanian language

I. INTRODUCTION

The vast amount of digitalized text and speech data has given incredible momentum to the discipline of Natural Language Processing (NLP) [1]. NLP is dedicated to how computers can complete tasks through direct understanding and manipulation of natural language text or speech [2]. In general, NLP use cases can be classified into Natural Language Understanding and Natural Language Generation which extends the task of just understanding natural languages to also producing meaningful text or speech. Depending on the scenario various NLP theories and techniques have been researched including (but not limited to) Automatic Summarization, Co-Reference Resolution, Discourse Analysis, Machine Translation, Morphological Segmentation, Named Entity Recognition, Optical Character Recognition, Topic Modeling, Sentiment Analysis and Part Of Speech Tagging [3].

Named Entity Recognition (NER) is a special NLP technique specialized in recognizing and categorizing named entities (such as people, objects, places, dates) that are presented in a text [4]. Once the named entities have been extracted, they can be indexed, searched, and linked through relations. Thus, NER serves as a cornerstone for other more complex NLP tasks like Question Answering, Automatic Summarization, Topic Modeling, Information Retrieval, and Machine Translation [5].

One setting where NER is actively researched and applied is biomedicine and healthcare, because much of the clinical information contained in Electronic Health Records (EHR) is in narrative form [6]. Indeed, it is reckoned that more than 80% of the currently available healthcare data is unstructured [7]. NER is used to parse EHR literature in search of anatomies, locations, diseases, chronic conditions, procedures, medicines,

prescriptions, laboratory results, body measurements, allergies and several qualifiers linked to them [8]. For instance, an allergy might be *severe* or *tolerable*, whereas medications are seldom accompanied with supplementary information such as *route*, *quantity*, *dose*, *frequency*, and *side-effects*. Not only does NER facilitate sensemaking and structuring of patient medical data but it also sets the foundation for subsequent downstream tasks such as clinical assertion status, clinical entity resolvers, and de-identification of sensitive data [7].

NER is not a solved task, and besides the theoretical and practical advancements in the field many areas still need research [4]. Clinical NER intuitively inherits the challenges of general NER and adds difficulties related specifically to the domain. Some prominent challenges of clinical NER are:

- 1) *Abbreviations*: Abbreviations are frequently used in biomedical text, and the number of novel abbreviations arises with the domain's development. Therefore, the challenge of matching the short form abbreviation with the contextually correct long form named entity is present [9].
- 2) *Negation*: The presence of a named entity in an EHR does not necessarily translate in the presence of the condition. Frequently, physicians note that a specific suspected disease is absent. Therefore, these negations should not be considered findings. [10]
- 3) *Flexible formatting*: Since EHR are written under time pressure, they do not abide to rigid formatting and include missing punctuation, parenthetical expressions and variable formatting semantics [11].
- 4) *Noisy and misspelled text*: Misspellings in digitalized EHR are caused from human errors but also Optical Character Recognition models that might have been used to digitalize paper-based documents [12].
- 5) *Linguistic issues and semantic enrichment*: Due to subjectivity in clinical practice the language used is highly nuanced, underlying concepts are expressed in multiple ways with high number of synonyms and homonyms which challenge entity linkage [13]. This problem is also referred to as disambiguation [14].
- 6) *Multiline Anatomy*: Frequently in EHR anatomy entities span in multiple lines making it cumbersome to detect the correct boundaries for the named entity [15].
- 7) *Lack of gold standard annotated data*: Annotating text for supervised learning in NER is resourceful because it requires domain experts to work on reasonable-sized corpora [16].
- 8) *Clinical data sensitivity*: Lack of annotated corpora is also fueled by issues of privacy in openly accessing EHR. This is why automatic de-identification remains a very active area of research [17] [18].
- 9) *Application in multiple business units*: The biomedical and clinical domain has a latitude of use cases depending on the business units [15]. The NER solutions should satisfy seamlessly or with subtle tuning the requirements of the different business units.
- 10) *Handling big data*: Large models of NER require huge corpora, multiple phases of pre-training and resourceful iterations for fine-tuning endangering the operability of the end model in a production setting [15].

On one hand, NLP is primarily focused on high-resource languages (English, Chinese) and techniques are scarcely adopted or studied for other languages [19]. On the other hand, healthcare advances are a priority of every government worldwide. Therefore, it is pivotal that NLP, and in particular clinical NER, models are explored for low-resource languages, as Albanian. In this paper we:

- 1) Contextualize clinical NER for Albanian language and explore Large Language Models (LLM) that might be adopted for the task,
- 2) Identify that the need for biomedical corpora and gold-standard annotated data are immediate next steps needed to research to complete the model production pipeline.

II. MATERIALS AND METHOD

To accomplish the creation of a NER solution in the clinical domain for Albanian language based on LLM we focused on researching on the model, the training corpora, and annotated domain-specific data. Therefore, we started exploratory research on the available NER solutions for low-resource languages as Albanian. Exploratory research is the most suitable methodology in this case due to the topic being under-researched [20].

For the exploratory research we browsed the online scientific libraries IEEE Xplore, Google Scholar, JSTOR and arXiv firstly on LLM implementations on low-resource languages for NER or general NLP tasks, and secondly on NER or general NLP tasks in Albanian.

On the first task, we used combinations of the keywords “NLP”, “NER”, “Large Language Model”, “non-English”. As a result, we screened a variety of LLM applications for NER or general NLP in various low/middle-resource languages like German [21], Spanish [22], Hebrew [23], and Portuguese [24] and various literature reviews published in the last years on LLM applications in NLP as in [8] [19] and [25].

On the second task, we used combinations of the keywords “NLP”, “NER”, “Albanian language”. From the screening of 70 results in Google Scholar, 7 results in IEEE Xplore, 1 result in arXiv and 23 results in JSTOR we conclude that:

- 1) while there are some applications regarding NLP tasks like Part Of Speech, Spell Checking and Sentiment Analysis, few research was done in the domain of NER (only 1 publication),
- 2) while there was one research dedicated to NER in Albanian, it was not domain-specific, and it did not share an in-production model [26].

III. RESULTS AND DISCUSSION

The extraction of clinical information from EHR has been done firstly through rule/dictionary approaches and now primarily through Machine Learning (ML) approaches. Within ML, unsupervised learning methods are based mostly on association and clustering, whereas the supervised learning methods are based mostly on Hidden Markov Model (HMM), Conditional Random Field (CFR) and Support Vector Machines (SVM) [19].

Recently, deep learning approaches have dominated research in the domain of NER. The thorough reviews on NER methodologies and tools published in 2023 in [8] [19] and [25] converge that the Large Language Model (LLM) Bidirectional Encoder Representation from Transformers (BERT) clinical variations have emerged as the pioneer NER model applied in clinical settings.

BERT clinical variations have even scored better than the Generative Pre-trained Transformers (GPT) models released by OpenAI ChatGPT in clinical NER [27]. ChatGPT versions have achieved state-of-the-art results in several NLP tasks such as Machine Translation, Question-Answering and zero-shot or few-shot learning scenarios [28]. The potential success of ChatGPT in medicine sparked after GPT-3.5 passed with 60% accuracy the US medical license exam [29] but the model failed to impress in the clinical domain.

As described in detail in [30], BERT framework is composed of two steps: pre-training and fine-tuning. Pre-training is done using two unsupervised tasks: Masked Language Model (MLM) and Next Sentence Prediction (NSP). BERT is pretrained on BooksCorpus (800M words) and English Wikipedia (2500M words). In the fine-tuning part task-specific inputs and outputs are plugged into BERT and the parameters are fine-tuned end-to-end. [30]

Pre-trained with biomedicine and clinical text BERT variations have outperformed their general versions when applied in a clinical setting [31]. Specifically state-of-the-art results in medical domain are achieved by:

- 1) *BioBERT*: the model was initialized using BERT and pre-trained in continuity using PubMed abstracts (4500M words) and PubMed Central full-text articles (13500M words) [24].
- 2) *ClinicalBERT* and *ClinicalBioBERT*: both models were initialized from respectively BERT and BioBERT and pre-trained in continuity on 2 million clinical notes part of the Medical Information Mart for Intensive Care (MIMIC-III v1.4) dataset (500M words) [32].
- 3) *SciBERT*: the model is pre-trained only on a random collection of 1.14 million papers from Semantic Scholar (3300M words) aiming at a domain-specific pre-training [33].
- 4) *PubMedBERT*: the model is pre-trained only on a collection of PubMed abstracts (3200M words) aiming at an only domain-specific pre-training [34].
- 5) *BlueBERT*: the model was initialized using BERT and pre-trained in continuity using PubMed abstracts (4000M words) and MIMIC-III dataset (500M words) simultaneously [35].

However, all the above state-of-the-art solutions cannot directly apply to languages other than English. A thorough review of studies in NLP in languages other than English published in [36] states that few Indo-European, Sino-Tibetan, Semitic and Altaic languages have been studied with respect to clinical NLP. Albanian is not present in this study, and based on the research we carried out on the online scientific libraries there is no study or application of clinical NLP in the context of Albania.

Interesting development for low-resource languages like Albanian are multilingual pre-trained models like MultilingualBERT (mBERT). mBERT was released as a single BERT language model pre-trained on corpora assembled from the Wikipedia content of 104 languages [30]. Albanian is included in the model as the seventy third language in the list of largest Wikipedia by number of articles.

mBERT has proven surprisingly good at cross-lingual generalization [37]. This property is known as zero-shot cross-lingual model transfer: the model is fine-tuned using task-specific supervised training data from high-resource languages and evaluated on that task in low-resource languages. For instance, is proven that mBERT fine-tuned on English data on a Question Answering task performs as good as it being trained directly in the target language [38]. Similarly, in an attempt at scaling the capacities of mBERT in terms of model and pre-training corpora [39] evaluates that it is possible to have a single large multilingual model without sacrificing the performance in monolingual tasks.

Several studies have followed the high performance of mBERT in an attempt to decode the rationale behind the success [37], [40]. One particular finding with high impact for the Albanian language is that mBERT success is not related with lexical similarity (shared words or word-parts) but rather structural similarities (world-ordering or world-frequency) [40]. Albanian is an old language with an estimation of 7.5 million native speakers and is the only language listed in the Albanoid branch of the Indo-European languages.

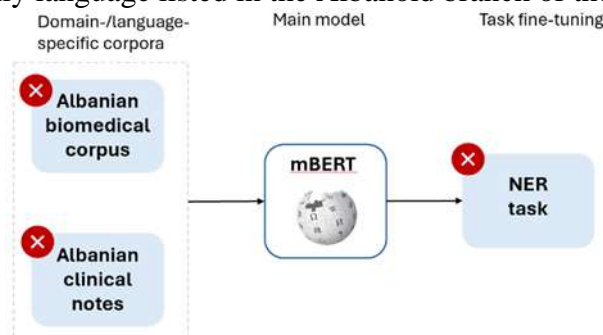

Figure 1 shows the aspired clinical NER model in Albanian initialized on mBERT

As concluded in [24], [32], [33], [34], [35] BERT models trained on general-domain corpora are outperformed by same capacity models trained on domain-specific corpora. Based on our thorough research, there is no biomedical or clinical corpora available in Albanian.

While the retrieval of clinical corpora requires the coordination between several academic, healthcare, and governmental institutions, the parsing of biomedical corpora might be more straightforward. For instance, a list of more than 500 PhD dissertations is publicly available from the University of Medicine in Tirana¹.

The challenge of lacking gold standard annotated data for task fine-tuning and evaluation is present in the Albanian endeavor of clinical NER. It would be an achievement to the progress of NER in Albanian if such data is produced.

IV. CONCLUSION

The spiking developments of NLP seem to have left the low-resource languages behind. Multilingual Large Language Models like mBERT have proven surprisingly good at zero-shot or few-shot cross-lingual model transfer. However, domain-specific tasks remain challenging due to their specific requirements. In particular, clinical NER is a task that is challenged by a myriad of issues related to the nature of the domain-specific language and lack of structure of the text.

In this exploratory paper we suggest the use of mBERT for the task of clinical NER in Albanian curated by continuous training using domain-specific corpora and the creation of a gold-standard annotated dataset for task evaluation as the best solution under the current circumstances. We aim to address both these issues in our imminent future work.

REFERENCES

- [1] Bahja, Mohammed, "Natural Language Processing Applications in Business," in *E-Business-higher education and intelligence applications*, 2020.
- [2] G. G. Chowdhury, "Natural Language Processing," *Fundam. Artif. Intell.*, pp. 603–649, 2020.
- [3] D. Khurana, A. Koli, K. Khatter, and S. Singh, "Natural language processing: state of the art, current trends and challenges," *Multimed. Tools Appl.*, vol. 82, no. 3, pp. 3713–3744, Jan. 2023, doi: 10.1007/s11042-022-13428-4.
- [4] M. Marrero, J. Urbano, S. Sánchez-Cuadrado, J. Morato, and J. M. Gómez-Berbis, "Named Entity Recognition: Fallacies, challenges and opportunities," *Comput. Stand. Interfaces*, vol. 35, no. 5, pp. 482–489, Sep. 2013, doi: 10.1016/j.csi.2012.09.004.
- [5] V. Yadav and S. Bethard, "A Survey on Recent Advances in Named Entity Recognition from Deep Learning models." arXiv, Oct. 24, 2019. Accessed: Mar. 02, 2024. [Online]. Available: <http://arxiv.org/abs/1910.11470>
- [6] D. Demner-Fushman, W. W. Chapman, and C. J. McDonald, "What can natural language processing do for clinical decision support?," *J. Biomed. Inform.*, vol. 42, no. 5, pp. 760–772, Oct. 2009, doi: 10.1016/j.jbi.2009.08.007.
- [7] V. Kocaman and D. Talby, "Accurate Clinical and Biomedical Named Entity Recognition at Scale," *Softw. Impacts*, vol. 13, p. 100373, Aug. 2022, doi: 10.1016/j.simpa.2022.100373.
- [8] D. Fraile Navarro *et al.*, "Clinical named entity recognition and relation extraction using natural language processing of medical free text: A systematic review," *Int. J. Med. Inf.*, vol. 177, p. 105122, Sep. 2023, doi: 10.1016/j.ijmedinf.2023.105122.
- [9] A. S. Schwartz and M. A. Hearst, "A SIMPLE ALGORITHM FOR IDENTIFYING ABBREVIATION DEFINITIONS IN BIOMEDICAL TEXT," in *Biocomputing 2003*, Kauai, Hawaii: WORLD SCIENTIFIC, Dec. 2002, pp. 451–462. doi: 10.1142/9789812776303_0042.
- [10] W. W. Chapman, W. Bridewell, P. Hanbury, G. F. Cooper, and B. G. Buchanan, "A Simple Algorithm for Identifying Negated Findings and Diseases in Discharge Summaries," *J. Biomed. Inform.*, vol. 34, no. 5, pp. 301–310, Oct. 2001, doi: 10.1006/jbin.2001.1029.
- [11] R. Leaman, R. Khare, and Z. Lu, "Challenges in clinical natural language processing for automated disorder normalization," *J. Biomed. Inform.*, vol. 57, pp. 28–37, Oct. 2015, doi: 10.1016/j.jbi.2015.07.010.
- [12] E. B. Lee, G. E. Heo, C. M. Choi, and M. Song, "MLM-based typographical error correction of unstructured medical texts for named entity recognition," *BMC Bioinformatics*, vol. 23, no. 1, p. 486, Nov. 2022, doi: 10.1186/s12859-022-05035-9.
- [13] A. Holzinger, J. Schantl, M. Schroettner, C. Seifert, and K. Verspoor, "Biomedical Text Mining: State-of-the-Art, Open Problems and Future Challenges," in *Interactive Knowledge Discovery and Data Mining in Biomedical Informatics*, vol. 8401, A. Holzinger and I. Jurisica, Eds., in Lecture Notes in Computer Science, vol. 8401. , Berlin, Heidelberg: Springer Berlin Heidelberg, 2014, pp. 271–300. doi: 10.1007/978-3-662-43968-5_16.
- [14] N. Perera, M. Dehmer, and F. Emmert-Streib, "Named Entity Recognition and Relation Detection for Biomedical Information Extraction," *Front. Cell Dev. Biol.*, vol. 8, p. 673, Aug. 2020, doi: 10.3389/fcell.2020.00673.

¹ <http://umed.edu.al/category/doktoraturat-sq/>

- [15] S. R. Kundeti, J. Vijayananda, S. Mujjiga, and M. Kalyan, “Clinical named entity recognition: Challenges and opportunities,” in *2016 IEEE International Conference on Big Data (Big Data)*, Washington DC, USA: IEEE, Dec. 2016, pp. 1937–1945. doi: 10.1109/BigData.2016.7840814.
- [16] M. Asghari, D. Sierra-Sosa, and A. S. Elmaghraby, “BINER: A low-cost biomedical named entity recognition,” *Inf. Sci.*, vol. 602, pp. 184–200, Jul. 2022, doi: 10.1016/j.ins.2022.04.037.
- [17] A. Névéol, P. Zweigenbaum, and Section Editors for the IMIA Yearbook Section on Clinical Natural Language Processing, “Clinical Natural Language Processing in 2014: Foundational Methods Supporting Efficient Healthcare,” *Yearb. Med. Inform.*, vol. 24, no. 01, pp. 194–198, Aug. 2015, doi: 10.15265/IY-2015-035.
- [18] H. Berg, A. Henriksson, and H. Dalianis, “The Impact of De-identification on Downstream Named Entity Recognition in Clinical Text,” in *Proceedings of the 11th International Workshop on Health Text Mining and Information Analysis*, Online: Association for Computational Linguistics, 2020, pp. 1–11. doi: 10.18653/v1/2020.louhi-1.1.
- [19] B. Jehangir, S. Radhakrishnan, and R. Agarwal, “A survey on Named Entity Recognition — datasets, tools, and methodologies,” *Nat. Lang. Process. J.*, vol. 3, p. 100017, Jun. 2023, doi: 10.1016/j.nlp.2023.100017.
- [20] P. Dash, “Analysis of Literature Review in case of Exploratory Research Method”.
- [21] B. Chan, S. Schweter, and T. Möller, “German’s Next Language Model.” arXiv, Dec. 03, 2020. Accessed: Mar. 05, 2024. [Online]. Available: <http://arxiv.org/abs/2010.10906>
- [22] A. Gutiérrez-Fandiño *et al.*, “MarIA: Spanish Language Models,” *Proces. Leng. Nat.*, pp. 39–60, 2022, doi: 10.26342/2022-68-3.
- [23] A. Seker, E. Bandel, D. Bareket, I. Brusilovsky, R. S. Greenfeld, and R. Tsarfaty, “AlephBERT: A Hebrew Large Pre-Trained Language Model to Start-off your Hebrew NLP Application With.” arXiv, Apr. 08, 2021. Accessed: Mar. 05, 2024. [Online]. Available: <http://arxiv.org/abs/2104.04052>
- [24] J. Lee *et al.*, “BioBERT: a pre-trained biomedical language representation model for biomedical text mining,” *Bioinformatics*, vol. 36, no. 4, pp. 1234–1240, Feb. 2020, doi: 10.1093/bioinformatics/btz682.
- [25] M. C. Durango, E. A. Torres-Silva, and A. Orozco-Duque, “Named Entity Recognition in Electronic Health Records: A Methodological Review,” *Healthc. Inform. Res.*, vol. 29, no. 4, pp. 286–300, Oct. 2023, doi: 10.4258/hir.2023.29.4.286.
- [26] L. Kryeziu and V. Shehu, “Bert Based Named Entity Recognition for the Albanian Language,” *Interdiscip. J. Res. Dev.*, vol. 10, no. 3, p. 7, Nov. 2023, doi: 10.56345/ijrdv10n302.
- [27] Y. Hu *et al.*, “Improving large language models for clinical named entity recognition via prompt engineering,” *J. Am. Med. Inform. Assoc.*, p. ocad259, Jan. 2024, doi: 10.1093/jamia/ocad259.
- [28] Y. Bang *et al.*, “A Multitask, Multilingual, Multimodal Evaluation of ChatGPT on Reasoning, Hallucination, and Interactivity.” arXiv, Nov. 28, 2023. Accessed: Mar. 02, 2024. [Online]. Available: <http://arxiv.org/abs/2302.04023>
- [29] A. Gilson *et al.*, “How Does ChatGPT Perform on the United States Medical Licensing Examination (USMLE)? The Implications of Large Language Models for Medical Education and Knowledge Assessment,” *JMIR Med. Educ.*, vol. 9, p. e45312, Feb. 2023, doi: 10.2196/45312.
- [30] J. Devlin, M.-W. Chang, K. Lee, and K. Toutanova, “BERT: Pre-training of Deep Bidirectional Transformers for Language Understanding.” arXiv, May 24, 2019. Accessed: Feb. 28, 2024. [Online]. Available: <http://arxiv.org/abs/1810.04805>
- [31] X. Yang, J. Bian, W. R. Hogan, and Y. Wu, “Clinical concept extraction using transformers,” *J. Am. Med. Inform. Assoc.*, vol. 27, no. 12, pp. 1935–1942, Dec. 2020, doi: 10.1093/jamia/ocaa189.
- [32] E. Alsentzer *et al.*, “Publicly Available Clinical BERT Embeddings.” arXiv, Jun. 20, 2019. Accessed: Mar. 03, 2024. [Online]. Available: <http://arxiv.org/abs/1904.03323>
- [33] I. Beltagy, K. Lo, and A. Cohan, “SciBERT: A Pretrained Language Model for Scientific Text.” arXiv, Sep. 10, 2019. Accessed: Mar. 03, 2024. [Online]. Available: <http://arxiv.org/abs/1903.10676>
- [34] Y. Gu *et al.*, “Domain-Specific Language Model Pretraining for Biomedical Natural Language Processing,” *ACM Trans. Comput. Healthc.*, vol. 3, no. 1, pp. 1–23, Jan. 2022, doi: 10.1145/3458754.
- [35] Y. Peng, S. Yan, and Z. Lu, “Transfer Learning in Biomedical Natural Language Processing: An Evaluation of BERT and ELMo on Ten Benchmarking Datasets.” arXiv, Jun. 18, 2019. Accessed: Mar. 03, 2024. [Online]. Available: <http://arxiv.org/abs/1906.05474>
- [36] A. Névéol, H. Dalianis, S. Velupillai, G. Savova, and P. Zweigenbaum, “Clinical Natural Language Processing in languages other than English: opportunities and challenges,” *J. Biomed. Semant.*, vol. 9, no. 1, p. 12, Dec. 2018, doi: 10.1186/s13326-018-0179-8.
- [37] T. Pires, E. Schlinger, and D. Garrette, “How multilingual is Multilingual BERT?” arXiv, Jun. 04, 2019. Accessed: Mar. 03, 2024. [Online]. Available: <http://arxiv.org/abs/1906.01502>
- [38] W. Sibli, C. Pasqual, A. Lavielle, M. Challal, and C. Cauchois, “Multilingual Question Answering from Formatted Text applied to Conversational Agents.” arXiv, Feb. 01, 2021. Accessed: Feb. 28, 2024. [Online]. Available: <http://arxiv.org/abs/1910.04659>
- [39] A. Conneau *et al.*, “Unsupervised Cross-lingual Representation Learning at Scale.” arXiv, Apr. 07, 2020. Accessed: Feb. 28, 2024. [Online]. Available: <http://arxiv.org/abs/1911.02116>
- [40] K. K. Z. Wang, S. Mayhew, and D. Roth, “Cross-Lingual Ability of Multilingual BERT: An Empirical Study.” arXiv, Feb. 15, 2020. Accessed: Mar. 03, 2024. [Online]. Available: <http://arxiv.org/abs/1912.07840>



YOLOv7 ve YOLOv8 Algoritmalarının Değerlendirilmesi: Savaş Uçaklarının Tespiti İçin Performans Analizi

Fatih Şengül^{1*}, Kemal Adem²

¹Dept. of Defense Technologies, Sivas University of Science and Technology, Turkey

²Dept. of Computer Engineering, Sivas University of Science and Technology, Turkey

*(tr.fatih.sengul@gmail.com)

Özet – Bu çalışmada, YOLOv7 ve YOLOv8 algoritmalarının farklı açılardan ve karmaşık arka plana sahip 43 sınıflı toplam 19514 görüntü içeren veri setinde savaş uçaklarının tespiti için performansı kesinlik, geri çağırma ve mAP metrikleri kullanılarak değerlendirilmiştir. Elde edilen sonuçlar, YOLOv8'in 0.940 mAP değeri ile YOLOv7'nin 0.902 mAP değerine kıyasla daha iyi performans gösterdiğini ortaya koymuştur. Her iki model de karmaşık arka plana sahip görüntülerde savaş uçaklarını başarıyla tespit edebilmiştir. YOLOv7 ve YOLOv8'in önceki versiyonlara göre daha fazla öğrenme kapasitesine sahip olması ve derin öğrenme tekniklerinin son güncellemelerini içermesi, nesne tespiti süreçlerini optimize ederek genel performansı artırmıştır. Bu çalışma, YOLOv8'in savaş uçaklarının tespiti için kullanılabilecek potansiyele sahip olduğunu göstermiştir.

Anahtar Kelimeler – YOLO, Bilgisayarla Görü, Nesne Tespiti, Derin Öğrenme, Savaş Uçağı

I. GİRİŞ

Savaş uçaklarının tespiti, ulusal güvenlik ve uluslararası ilişkiler açısından hayati bir öneme sahiptir. Düşman uçaklarının erken tespiti, hava kuvvetlerinin zamanında müdahale etmesine ve hava sahası hakimiyetinin korunmasına olanak tanır. Ayrıca savaş uçaklarının tespiti, bir ülkenin hava sahasının ihlal edilmesi durumunda erken uyarı ve savunma tedbirlerinin alınmasını sağlar. Bu, bir saldırının önlenmesine veya etkilerinin en aza indirilmesine yardımcı olabilir. Ayrıca, savaş uçaklarının tespiti, uluslararası ilişkilerde güvenin korunması için önemlidir. Bir ülkenin hava sahasının izinsiz olarak ihlal edilmesi, diplomatik krizlere ve hatta askeri çatışmalara yol açabilir. Dolayısıyla, savaş uçaklarının tespiti, uluslararası barış ve istikrarın sağlanması açısından da kritik bir rol oynar.

Şu anda, savaş uçaklarının tespiti konusunda çeşitli kısıtlamalar bulunmaktadır. Bunlar teknik, politik ve stratejik faktörlerden kaynaklanmaktadır. Teknik olarak, bazı savaş uçakları gelişmiş teknolojilerle donatılmıştır ve radar sinyallerini tespit etmeyi zorlaştıran önlemler almışlardır. Bu durum, savaş uçaklarının tespit edilmesini zorlaştırabilir ve erken uyarı sistemlerinin etkinliğini azaltabilir. Ayrıca, politik kısıtlamalar da savaş uçaklarının tespitini etkileyebilir. Birçok ülke, kendi hava sahasının ihlal edilmesini önlemek için radar ve diğer tespit sistemlerini kullanırken, bu tür faaliyetleri yabancı ülkelerin hava sahasında gerçekleştirmek istemeyebilir. Son olarak, stratejik kısıtlamalar da savaş uçaklarının tespitini etkileyebilir. Bazı ülkeler, diğer ülkelerin hava sahasını ihlal etme eylemlerini diplomatik nedenlerle göz ardı etmek veya tolere etmek isteyebilir.

Bu kısıtlamalara rağmen, savaş uçaklarının tespiti konusundaki teknolojik gelişmeler devam etmektedir. Yeni radar sistemleri, uydu izleme teknolojileri ve yapay zeka destekli tespit sistemleri, savaş uçaklarını tespit etme kabiliyetini artırmak için sürekli olarak geliştirilmektedir. Ancak, savaş uçaklarının tespiti konusundaki zorluklar devam etmektedir. Bu alandaki çalışmalar, ulusal güvenlik ve uluslararası ilişkiler açısından önemini korumaktadır.

Savaş uçaklarının tespiti, nesne tespiti teknolojilerinin askeri ve stratejik açıdan önemli bir uygulama alanıdır. Gelişmiş nesne tespiti modelleri, özellikle savaş uçaklarının tespitini hızlı ve doğru bir şekilde gerçekleştirebilirse, ulusal güvenlik açısından büyük bir avantaj sağlayabilir. Ancak savaş uçaklarının tespiti, çeşitli zorluklarla karşı karşıyadır ve mevcut nesne tespiti teknolojileriyle aşılması gereken bazı kısıtlamalar bulunmaktadır.

Yapay zeka, nesne tespiti ve sınıflandırma alanında son yıllarda önemli ilerlemeler kaydetmiştir. Özellikle YOLO (You Only Look Once) gibi yenilikçi nesne tespit modelleri, görüntü işleme alanında devrim niteliğinde gelişmeler sağlamıştır. YOLOv7 ve YOLOv8 gibi yeni sürümler, daha hızlı ve daha doğru nesne tespiti sağlayarak birçok uygulama alanında önemli bir avantaj sunmaktadır. Bu modeller, nesne tespitini gerçek zamanlı olarak gerçekleştirebilen tek bir end-to-end derin öğrenme modeli olarak tasarlanmıştır. YOLO'nun özgün yaklaşımı, bir görüntüyü bir grid'e böler, ardından her bir hücrenin belirli bir sayıda kutuya ve her kutuya ait nesnelerin olasılıklarını tahmin eden bir sistemdir. Bu yöntem, diğer geleneksel nesne tespiti modellerinden daha hızlı çalışır ve daha düşük bir işleme maliyetine sahiptir.

Ancak nesne tespiti teknolojileri, özellikle savaş uçaklarının tespiti gibi stratejik öneme sahip alanlarda bazı zorluklarla karşı karşıyadır. Savaş uçaklarının tespiti, ulusal güvenlik açısından kritik bir konudur ve mevcut nesne tespiti modelleriyle aşılması gereken bazı kısıtlamalar bulunmaktadır. Özellikle, düşman uçaklarının düşük irtifalarda uçuşması veya arka plan gürültüsüne karışması gibi faktörler, nesne tespitini zorlaştırabilmektedir.

YOLO gibi gelişmiş nesne tespiti modelleri, savaş uçaklarının tespiti gibi stratejik öneme sahip bir alanda önemli bir avantaj sağlayabilir. Özellikle görüntüler üzerinde YOLO'nun hızlı çalışma özelliği, savaş uçaklarının tespiti için kullanıldığında, hızlı tepki ve gerçek zamanlı bilgi sağlama yeteneği, ulusal savunma sistemlerinin etkinliğini artırabilir.

Mevcut kısıtlamaları aşmak ve bu modellerin daha da geliştirilmesi, ulusal güvenlik açısından kritik olan savaş uçaklarının tespiti için daha etkin bir araç olmalarını sağlamak için birçok araştırma yapılmıştır. Wang ve diğerleri, havadan görüntülerde uçak tespiti için TransEffiDet isimli bir yöntem önermişlerdir. Bu yöntemde, EfficientDet omurga ağı olarak kullanılırken, uzun menzilli bağımlılıkları yakalamak ve özellik çıkarımı işlemini geliştirmek için deforme edilebilir Transformer modülü eklenmiştir. Bu yöntem, %86,6'lık ortalama Kesinlik (mAP) değeri elde ederek EfficientDet'i %5,8 oranında geride bırakmıştır [1]. Bir diğer çalışmada ise Yang ve diğerleri, uzaktan algılama görüntülerinde gerçek zamanlı uçak tespiti için YOLOv4 nesne algılama algoritmasını temel alan bir yöntem önermektedir. Bu yöntemde, YOLOv4 iyileştirilerek Aircraft-YOLOv4 adlı yeni bir model önerilmiştir. Aircraft-YOLOv4, uzak algılama görüntülerinde uçak nesnelerini tespit ederken %86.92'lik ortalama Kesinlik (mAP) ve 29.62 kare/saniye (fps) değerlerine ulaşarak gerçek zamanlı tespiti başarıyla gerçekleştirir. Bu değerler, standart YOLOv4 modelinden sırasıyla %2.82 ve %7.01 daha yüksektir [2]. Savaş uçaklarının tespiti alanında yapılan bir diğer çalışmada ise, düşman veya dost olmayan hava araçlarının radar tespitinden kaçınmak için alçak irtifada uçmalarına veya doğal engellerin arkasına saklanmalarına çözüm olarak görsel uçak tanıma (VACR) yönteminden faydalanan bir yapay zeka tabanlı askerî uçak tanıma ve kimliklendirme sistemi önermektedir. Sistem, yapay sinir ağları (BPNN) ve bilgi füzyonu tekniklerini birleştirerek tanıma ve kimliklendirme sürecini hızlandırmayı amaçlamaktadır. Önerilen sistemde, 13 adet uçak özelliği 5 temel özelliğe dönüştürülerek BPNN'e girdi olarak verilmekte, havacı askerlerin VACR eğitimlerindeki zorlukları azaltması hedeflenmektedir. Sistem, 85 askerî uçak ve helikopter ile 70 sivil uçak ve helikopterden oluşan 155 veriyi kullanarak %80:20 oranında eğitim ve test verisi olarak bölmektedir. Eğitim ve test aşamasında sırasıyla %95.33 ve %87 doğruluk elde edilmiştir [3]. Li ve diğerleri ise 2023 yılında YOLO-class modeli önerdiler. Öncelikle, YOLO-Extract modeli, küçük, yoğun veya örtüşen hedeflerin tespitini optimize etmek için kullanılmıştır. Ardından, Temsili Batch Normalizasyon (RBN) ve Mish aktivasyon fonksiyonu kullanılarak Conv modülü optimize edilmiş, veri dengesizliğinden kaynaklanan doğruluk kaybını azaltmak için VariFocal kayıp fonksiyonu sınıflandırma kayıp fonksiyonunu optimize etmek için kullanılmıştır. Son olarak, omurgada RepVGG modülleri tasarlanarak modelin tespit doğruluğu daha da iyileştirilmiştir. Önerilen modelin sonuçları, YOLO-Extract modeli ile karşılaştırıldığında, YOLO-class modelinin tespit doğruluğunu 0,608'den 0,704'e, kare/saniye değerini ise 36,16'dan 39,598'e yükselttiğini göstermektedir[4]. Rujie ve diğerleri, büyük ölçekli askeri havaalanı uydu

görüntülerinde uçak tespiti ve tanıma için CNN tabanlı bir yöntem önermişlerdir. Önerilen yöntem sonuçları, her bir giriş görüntüsünü işleme için ortalama sürenin 5.765 saniye olduğunu, doğruluk oranının %79.2 olduğunu ve geri çağırma oranının %65.1 olduğunu ortaya koymaktadır. Sınıflandırma ağının ortalama süresi ise 0.972 saniye olup Top-1 hata oranı %13'tür [5]. Diğer bir çalışmada ise, çoklu uydu tabanlı veriler kullanılarak uçak hedeflerinin tespiti için bir yöntem önerilmiştir. Önerilen yöntem, Gabor filtreleme, görüntü ikileştirme ve bölgesel Unicom gibi yöntemlerle aday alanlar belirlenir ve ardından dairesel eşleşme filtreleme kullanılarak aday alanlar daha da hassaslaştırılır. Yapılan deneyler, önerilen yöntemin uçak hedeflerinin tespiti için %90'lık bir doğruluk sağladığını ve tespit süresinin 0.5 saniyenin altında olduğunu göstermektedir [6]. Bir diğer YOLO yöntemi ile geliştirilen çalışma, uzaktan algılama görüntülerinde uçak tespiti için You Only Look Once v3 temelli bir tespit süreci önermiştir. Farklı eğitim veri kombinasyonları altında önerilen modelin genelleme yeteneği değerlendirilmiş ve daha fazla yakınlaştırma seviyesindeki çeşitlilikten kaynaklanan daha fazla yanlış alarm tespitine işaret edilmiştir. Ancak, sabit bir yakınlaştırma seviyesinde obje boyutlarındaki çeşitliliğin olumlu bir etkisi olduğu belirtilmiş ve çalışma, 7 ila 77 m uzunluğundaki geniş bir uçak boyut aralığını %0.98 F1 skoruyla tespit edebildiğini göstermiştir [7].

Bu çalışma kapsamında 43 tip savaş uçağının tespit edilerek sınıflandırılması için YOLOv7 ve YOLOv8 modelleri kullanılmıştır. Elde edilen sonuçlar karşılaştırılarak savaş uçağı tespitinde güncel nesne tespiti için kullanılan yöntemlerin başarıları ortaya konulmuştur.

II. MATERYAL VE YÖNTEM

Çalışmanın bu bölümünde, veri seti ve kullanılan nesne tespiti yöntemleri ayrıntılı olarak açıklanmıştır.

A. Veri Seti

Savaş uçaklarının tespitini yapabilmek için 43 sınıflı görsel veri seti kullanılmıştır. Veri seti Kaggle platformu üzerinde açık kaynak olarak sunulmaktadır. Veri seti içerisinde 43 sınıfa ait savaş uçağı görüntüleri, farklı açılardan ve farklı arka plan görüntülerinden oluşmaktadır. Toplamda 19514 görsel veri bulunan veri seti içerisindeki sınıf ve veri dağılımı Figure 1 görülmektedir.

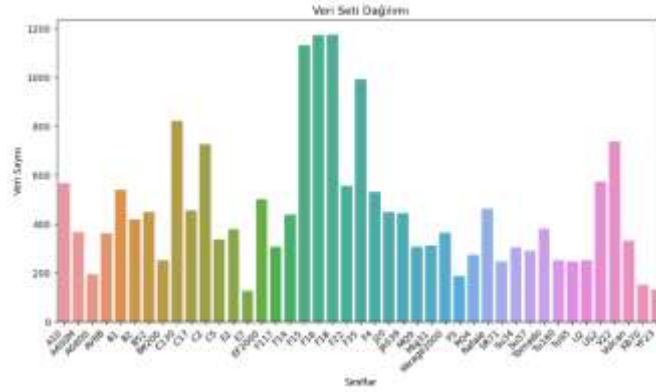

Figure 1. Veri Seti Dağılımı

B. YOLO

Nesne tespiti, bilgisayarlı görmenin en önemli alanlarından biridir ve YOLO, bu alanda öne çıkan bir algoritmadır. YOLO'nun en büyük avantajı, tek seferde tüm görüntüyü inceleyebilmesidir. Bu sayede diğer algoritmalara kıyasla çok daha hızlı çalışır ve nesnelere arka plandan daha iyi ayırabilir.

Yolo, görüntüyü parçalara ayırır ve her parçada nesne arar. Her parça için tahmini kutucuklar ve bu kutucuklara ait güven skorları üretir. Güven skoru, kutucuğun bir nesneye denk gelip gelmediğini ve nesnenin sınıfını ne kadar doğru tahmin ettiğini gösterir. En yüksek güven skoruna sahip kutucuklar seçilir ve nesnelere konumları ve sınıfları bu şekilde belirlenir. Yolo, bu sayede çok hızlı ve doğru bir şekilde nesne tespiti yapabilir [8]. YOLO algoritması yıllar içinde önemli geliştirmeler geçirmiştir ve artan verimlilikle birçok yeni versiyonları ortaya çıkmıştır [9].

YOLOv7, 2022 yılında YOLOv4'ün geliştiricileri tarafından sunulmuştur ve o dönemde bilinen tüm nesne dedektörlerini hem hız hem de doğruluk açısından geride bırakmıştır [10]. 5 FPS ila 160 FPS aralığında çalışan YOLOv7, tıpkı YOLOv4 gibi, önceden eğitilmiş omurgalar olmadan sadece MS COCO veri kümesi kullanılarak eğitilmiştir. YOLOv7, birkaç mimari değişiklik ve "serbest torba" adı verilen bir dizi yenilik ile çıkarım hızını etkilemeden doğruluğu artırmayı başarmıştır. Bu değişiklikler sadece eğitim süresini uzatmaktadır. En kısa en uzun gradyanı kontrol ederek derin öğrenme modellerinin daha verimli bir şekilde öğrenmesini ve yakınsamasını sağlayan E-ELAN (Genişletilmiş Verimli Katman Toplama Ağı) kullanır. Birleştirmeye dayalı model ölçeklendirme, modelin donanım kullanımını azaltmak için geliştirilmiştir [9].

YOLOv8, 2023 Ocak ayında YOLOv5'in arkasındaki ekip olan Ultralytics tarafından geliştirilmiştir [11]. YOLOv8, daha az sayıda kutu tahmini ve daha hızlı NMS (Maximum Non-Suppression) ile daha basit bir yapıya sahiptir [12]. YOLOv8 mimarisi, YOLOv5'e benzer bir temel yapı kullanır ancak C2f modülü olarak adlandırılan CSPLayer'da bazı değişiklikler yapılmıştır. C2f modülü (iki konvolüsyonlu çapraz aşamalı kısmi darboğaz), yüksek seviyeli özellikleri bağlamsal bilgilerle birleştirerek algılama doğruluğunu artırır [13].

III. BULGULAR

Bu çalışma kapsamında, literatürde nesne tespit uygulamalarındaki gerçek zamanlı çalışmaları ile dikkat çeken YOLOv7, YOLOv8 modellerinin savaş uçaklarının tespiti için performans analizleri yapılmıştır. Aynı veri seti kullanarak iki model de eğitilmiş ve ardından test edilmiştir. Model eğitimleri farklı hiperparametreler ile birçok deney gerçekleştirilmiştir. Ancak en iyi sonuçları YOLOv8'in varsayılan değerleri ile elde edilmiştir. Modellerin eğitiminde, epoch değeri 55'e, learning rate parametresi ise 0.001 olarak belirlenmiştir. Ancak YOLOv7 modelinde batch_size değeri varsayılandan farklı olarak 20 olarak ayarlanmıştır. Her iki modelde de optimizasyon algoritması olarak Adam kullanılmıştır. Bu çalışmada, algoritmaların başarısını değerlendirmek için Kesinlik (Precision), Geri Çağırma (Recall) ve mAP metrikleri kullanılmıştır.

Kesinlik, modelin "pozitif" olarak tahmin ettiği örneklerin ne kadarının gerçekte "pozitif" olduğunu gösterir. Geri Çağırma ise gerçekte "pozitif" olan örneklerin ne kadarının model tarafından "pozitif" olarak tahmin edildiğini gösterir.

mAP değeri, ortalama hassasiyetin belirli bir eşik değerine (0.5 olarak belirlenmiştir) göre hesaplanan ortalama hassasiyet değeridir. Bu değer, nesne algılama veya nesne tanıma algoritmalarının performansını değerlendirmede kullanılır. mAP değeri, algoritmanın ne kadar doğru nesnelere tespit ettiğini ve bu nesnelere doğruluğunu ne kadar koruduğunu gösterir. Yüksek bir mAP değeri, algoritmanın doğruluk ve kararlılığı açısından daha başarılı olduğunu gösterir. Ayrıca, mAP değeri, 0.5 eşik değeri altındaki hassasiyetlerin ortalamasını alarak hesaplanır. Bu, algoritmanın daha kesin sonuçlar veren bir eşik değeri üzerinde çalıştığı zaman daha iyi performans gösterdiğini gösterir. Nesne algılama modelinin mAP değeri ne kadar yüksekse, algılama yapma yeteneğinin ve algılanan nesnelere doğruluğunun o kadar yüksek olduğu söylenebilir.

YOLOv7 ve YOLOv8 modelleri savaş uçaklarının tespiti için test edildiğinde sırasıyla 0.902 ve 0.940 mAP değerleri elde edilmiştir.

Modeller test edildiğinde ve ilgili metriklere göre tüm sınıflardaki başarısına göre alınan sonuçlar Table 1'da görüldüğü gibidir.

Table 1. YOLOv7 ve YOLOv8 Modellerinin Nesne Tespiti Sonuçları

Model	Geri Çağırma	Kesinlik	mAP
YOLOv7	0.827	0.907	0.902
YOLOv8	0.881	0.924	0.940

Ayrıca YOLOv7 ve YOLOv8 modellerinin testlerdeki başarısı sırasıyla Figure 2'da ve Figure 3'da verilen karmaşıklık matrisinde de görülmektedir.

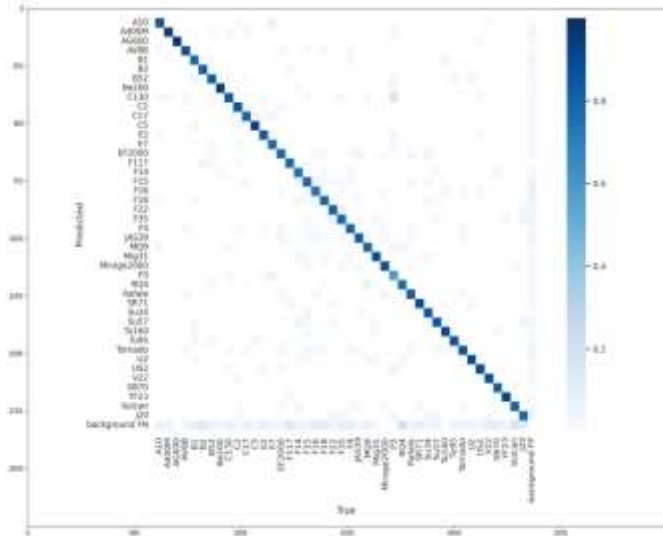

Figure 2. YOLOv7 Modeline Ait Karmaşıklık Matrisi

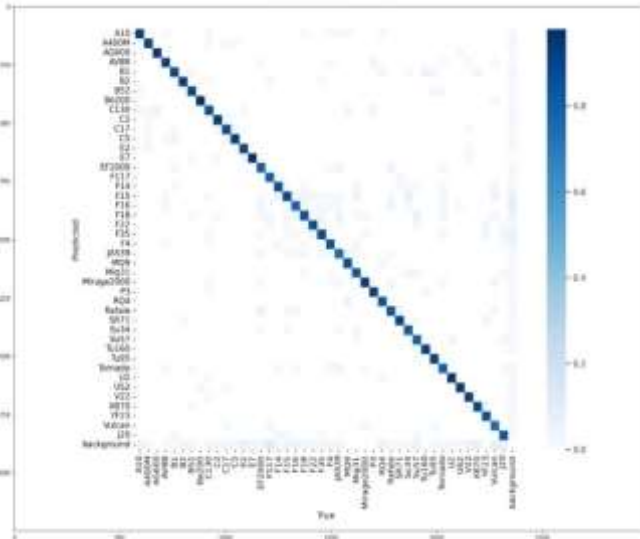

Figure 3. YOLOv8 Modeline Ait Karmaşıklık Matrisi

Figure 2 ve Figure 3’de diyagonaldeki hücreler, modelin doğru tahmin ettiği örneklerin sayısını gösterir. Diyagonal dışındaki hücreler, modelin yanlış tahmin ettiği örneklerin sayısını gösterir. Diyagonal dışında ayrı bir durum oluşmadığı karmaşıklık matrislerinde görülmektedir. Bu durum YOLOv7 ve YOLOv8 modelleri tüm sınıflarda yüksek tespit oranına ulaştığını göstermektedir.

IV. TARTIŞMA

Nesne tespiti alanında öne çıkan YOLO (You Only Look Once) algoritmaları, özellikle farklı açılardan ve karmaşık arka plana sahip görüntülerde savaş uçaklarının tespiti konusunda başarıları değerlendirilmiştir. Bu algoritmalar, geniş uygulama alanları ve hızlı işlem kapasitesi ile bilinirken, YOLOv7 ve YOLOv8 gibi en güncel versiyonlar, savaş uçaklarının tespitinde başarı sonuçlar elde edilmesini sağlamıştır.

YOLOv7 ve YOLOv8 modelleri, önceki versiyonlara kıyasla daha fazla öğrenme kapasitesine sahiptir. Bu modeller, derin öğrenme tekniklerinin son güncellemelerini içererek nesne tespiti süreçlerini optimize etmiş ve genel performanslarını artırmıştır. Özellikle karmaşık arka plana sahip görüntülerde, bu modellerin savaş uçaklarını başarıyla tespit etme yetenekleri, nesne tespiti alanındaki önemli gelişmeleri ortaya koymaktadır.

YOLOv8 mimarisi, nesnelerin bilinen sınırlayıcı kutulardan uzaklıklarını tahmin etmek yerine, doğrudan nesnelerin merkezlerini tahmin etmektedir. Bu sayede, çıkarım sonrası aşamada kullanılan ve aday

algılamaları sıralamak için gerekli olan Maksimum Olmayan Bastırma (NMS) işlemi daha hızlı hale gelmektedir. Ayrıca, bağlantısız algılama yöntemi sayesinde kutu tahminlerinin sayısı azaltılmış ve bu da savaş uçaklarının tespitinde daha iyi sonuçlar elde edilmesini sağlamıştır.

V. SONUÇLAR

Bu çalışmada farklı arka plana ve açığa sahip savaş uçakları görüntüleri kullanılarak 43 tip savaş uçağının tespit edilerek sınıflandırılması amaçlanmıştır. Savaş uçaklarının tespiti için YOLO yönteminin en güncel versiyonları olan YOLOv7 ve YOLOv8 kullanılmıştır. Modeller, aynı veri seti ile eğitilmiş ve test edilmiştir. Testler sonucunda mAP değerleri YOLOv7 için 0.902 iken YOLOv8 için 0.940 olduğu ortaya konulmuştur. Bulunan sonuçlar YOLO'nun en güncel versiyonu olan YOLOv8'in daha başarılı olduğunu göstermiştir.

Bu çalışmada, YOLOv7 ve YOLOv8 modellerinin savaş uçaklarının tespiti için performansı karşılaştırılmıştır. Elde edilen sonuçlar, her iki modelin de yüksek doğruluk oranlarına sahip olduğunu göstermiştir. Ancak, görüntü işleme yöntemlerinin ön işlem olarak kullanılmasının, modelin performansını daha da iyileştirebileceği düşünülmektedir. Görüntü işleme yöntemleri, gürültü ve kontrast gibi problemleri ortadan kaldırarak görüntü kalitesini iyileştirebilir. Bu da, derin öğrenme modellerinin daha doğru ve daha tutarlı tahminler yapmasını sağlayabilir.

KAYNAKLAR

- [1] Y. Wang *et al.*, “TransEffiDet: Aircraft Detection and Classification in Aerial Images Based on EfficientDet and Transformer,” *Comput Intell Neurosci*, vol. 2022, 2022, doi: 10.1155/2022/2262549.
- [2] Y. Yang, G. Xie, and Y. Qu, “Real-time Detection of Aircraft Objects in Remote Sensing Images Based on Improved YOLOv4,” *IEEE Advanced Information Technology, Electronic and Automation Control Conference (IAEAC)*, pp. 1156–1164, 2021, doi: 10.1109/IAEAC50856.2021.9390673.
- [3] A. Datumaya Wahyudi Sumari, S. Lovrenčić, D. Eka Adinandra, A. Rachmad Syulistyo, and S. Lovrencic, “Intelligent Military Aircraft Recognition and Identification to Support Military Personnel on the Air Observation Operation,” *Article in International Journal on Advanced Science Engineering and Information Technology*, vol. 12, no. 6, 2022, doi: 10.18517/ijaseit.12.6.16944.
- [4] Z. Liu, Y. Gao, and Q. Du, “YOLO-Class: Detection and Classification of Aircraft Targets in Satellite Remote Sensing Images Based on YOLO-Extract,” *IEEE Access*, vol. 11, pp. 109179–109188, 2023, doi: 10.1109/ACCESS.2023.3321828.
- [5] Y. Rujie, Y. Zhen, and X. Huilin, “Aircraft detection and recognition based on deep convolutional neural network,” *Journal of Computer Applications*, vol. 37, no. 6, p. 1702, Jun. 2017, doi: 10.11772/J.ISSN.1001-9081.2017.06.1702.
- [6] L. Yu, Q. Yang, and L. Dong, “Aircraft target detection using multimodal satellite-based data,” *Signal Processing*, vol. 155, pp. 358–367, Feb. 2019, doi: 10.1016/J.SIGPRO.2018.09.006.
- [7] Y.-C. Lin and W.-D. Chen, “Automatic aircraft detection in very-high-resolution satellite imagery using a YOLOv3-based process,” <https://doi.org/10.1117/1.JRS.15.018502>, vol. 15, no. 1, p. 018502, Jan. 2021, doi: 10.1117/1.JRS.15.018502.
- [8] J. Redmon, S. Divvala, R. Girshick, and A. Farhadi, “You only look once: Unified, real-time object detection,” *Proceedings of the IEEE Computer Society Conference on Computer Vision and Pattern Recognition*, vol. 2016-December, pp. 779–788, Dec. 2016, doi: 10.1109/CVPR.2016.91.
- [9] B. Gašparović, G. Mauša, J. Rukavina, and J. Lerga, “Evaluating YOLOV5, YOLOV6, YOLOV7, and YOLOV8 in Underwater Environment: Is There Real Improvement?,” *2023 8th International Conference on Smart and Sustainable Technologies, SpliTech 2023*, 2023, doi: 10.23919/SPLITECH58164.2023.10193505.
- [10] C.-Y. Wang, A. Bochkovskiy, and H.-Y. M. Liao, “YOLOv7: Trainable Bag-of-Freebies Sets New State-of-the-Art for Real-Time Object Detectors.” pp. 7464–7475, 2023. Accessed: Mar. 04, 2024. [Online]. Available: <https://github.com/>
- [11] F. N. Ortatas and M. Kaya, “Performance Evaluation of YOLOv5, YOLOv7, and YOLOv8 Models in Traffic Sign Detection,” *UBMK 2023 - Proceedings: 8th International Conference on Computer Science and Engineering*, pp. 151–156, 2023, doi: 10.1109/UBMK59864.2023.10286611.

- [12] Sandhya and A. Kashyap, “A novel method for real-time object-based copy-move tampering localization in videos using fine-tuned YOLO V8,” *Forensic Science International: Digital Investigation*, vol. 48, p. 301663, Mar. 2024, doi: 10.1016/J.FSIDI.2023.301663.
- [13] J. Terven, D. M. Córdova-Esparza, and J. A. Romero-González, “A Comprehensive Review of YOLO Architectures in Computer Vision: From YOLOv1 to YOLOv8 and YOLO-NAS,” *Machine Learning and Knowledge Extraction 2023*, Vol. 5, Pages 1680-1716, vol. 5, no. 4, pp. 1680–1716, Nov. 2023, doi: 10.3390/MAKE5040083.



Machine Learning Models for Predicting and Reducing Vehicle Emissions to Improve Air Quality

Beytullah Eren^{1,2,*} and Idris Cesur³

¹ Department of Environmental Engineering, Faculty of Engineering, Sakarya University, Serdivan, Sakarya, Türkiye.

² Sakarya University Technology Development Zones Management Inc. (Sakarya Teknokent), Sakarya University Esentepe Campus, Serdivan, Sakarya, Türkiye.

³ Sakarya University of Applied Sciences, Faculty of Technology, Department of Mechanical Engineering, 54187, Sakarya, Türkiye

* (beren@sakarya.edu.tr)

Abstract – Controlling vehicle emissions is crucial for improving urban air quality and mitigating environmental damage. Traditional approaches to emission control face limitations in accuracy and adaptability. To address these challenges, this study explores the potential of machine learning models in predicting and reducing vehicle emissions. Machine learning can accurately forecast emission levels, consider several factors influencing emissions, and optimize mitigation strategies. Real-time monitoring of vehicle emissions using sensor networks and IoT devices enables prompt interventions and informed decision-making. Machine learning algorithms facilitate detecting pollution events, identifying hotspots, and proactive measures to reduce environmental impacts. Case studies demonstrate the effectiveness of machine learning in emission prediction and real-time monitoring across various contexts. However, data quality and model interpretability must be addressed to maximize the effectiveness of machine learning-based mitigation strategies. Collaborative efforts among researchers, policymakers, industry stakeholders, and the public are essential for advancing machine learning applications in sustainable urban development.

Keywords – Vehicle Emissions; Air Quality; Machine Learning; Real-Time Monitoring; Environmental Sustainability; Emission Reduction

I. INTRODUCTION

Controlling vehicle emissions and improving air quality are among the most crucial challenges in today's urban environments. Vehicles emit various pollutants, such as nitrogen oxides, particulate matter, carbon monoxide, and volatile organic compounds, which can damage human health and the environment [1], [2]. Exposure to these pollutants has been linked to respiratory diseases, cardiovascular problems, and even premature death, particularly impacting vulnerable populations such as children, the elderly, and individuals with pre-existing health conditions due to their harmful effects on air quality [3], [4], [5].

Air quality degradation is more significant in urban areas, especially where vehicular traffic is dense. The high concentration of pollutants emitted by vehicles contributes to smog, haze, and ozone formation, reducing visibility and increasing respiratory diseases among residents [6], [7]. Moreover, vehicle emissions significantly contribute to climate change by releasing greenhouse gases like carbon dioxide into the atmosphere. The transport industry contributes significantly to carbon dioxide emissions, worsening the effects of global warming, such as increasing temperatures, rising sea levels, and extreme weather occurrences [8], [9].

Governments and regulatory authorities have implemented various measures to control vehicle emissions and enhance air quality to address these challenges. These measures include introducing stringent emission standards, fuel efficiency regulations, vehicle inspection programs, and incentives for adopting cleaner transportation technologies [8], [10], [11]. Moreover, technological advancements, such as electric

vehicles, hybrid vehicles, and alternative fuels, offer promising solutions for reducing vehicle emissions and environmental impacts [12], [13].

Traditional approaches to controlling vehicle emissions have focused on regulations and technological advancements in vehicle design and fuel composition [10]. Regulatory measures involve setting emission standards, like the Euro standards in Europe and Tier standards in the United States, which define the maximum allowable pollutants emitted by vehicles. These standards are designed to encourage the development and use of cleaner vehicle technologies by imposing penalties for non-compliance [14]. Technological advancements have mainly focused on enhancing engine design, exhaust after-treatment systems, and the creation of cleaner-burning fuels. Innovations in engine technology, such as catalytic converters and diesel particulate filters, help reduce emissions of harmful pollutants like nitrogen oxides and particulate matter [15]. Moreover, using alternative fuels such as biodiesel and compressed natural gas aims to minimize the carbon footprint of vehicles and mitigate environmental impacts [16].

Traditional approaches to reducing vehicle emissions have limitations due to reliance on static emission standards, challenges in enforcing regulatory compliance, and high costs of technological improvements. These factors, along with consumer preferences and infrastructure limitations, hinder their effectiveness, especially in regions with limited resources [17], [18]. As a result, there is increasing recognition of the need for innovative solutions like machine learning models to address the complexities of vehicle emissions and air quality enhancement.

Machine learning is a promising solution for developing emission control in the transportation sector. With the increasing urgency to address the environmental impact of vehicle emissions and improve air quality, traditional approaches face limitations in accuracy, efficiency, and adaptability to dynamic real-world conditions. In contrast, machine learning utilizes advanced algorithms to analyze large datasets, identify patterns, and make accurate predictions at unprecedented speed [19].

Machine learning enables computers to learn from data, make predictions, and uncover hidden patterns, making it perfect for tackling emission control in transportation. It offers a powerful tool for predicting future emission levels by considering a variety of input parameters, such as vehicle characteristics, driving behavior, weather conditions, and traffic congestion [20]. These predictive models provide valuable insights for policymakers, urban planners, and regulatory bodies to develop proactive strategies for reducing emissions and enhancing air quality.

In addition to its predictive abilities, machine learning is pivotal in enhancing real-time monitoring and management of vehicle emissions. This is achieved by integrating sensor networks, IoT devices, and remote sensing technologies. By analyzing continuous data streams from these sources, machine learning algorithms can quickly identify anomalies, pinpoint emission hotspots, and issue early warnings of potential pollution events. This real-time monitoring capability allows immediate interventions and informed decision-making to mitigate environmental impacts and protect public health [21].

Furthermore, machine learning can potentially optimize emission reduction strategies by identifying the most effective interventions and resource distributions based on historical data and predictive analytics. Organizations can select investments in cleaner technologies, infrastructure upgrades, and regulatory enforcement actions through this data-driven approach to maximize environmental benefits while minimizing costs. Utilizing machine learning tools and techniques, experts can make well-informed decisions that significantly improve air quality and sustainability [22], [23].

Overall, this study addresses the pressing issue of controlling vehicle emissions and improving air quality in urban environments by exploring the potential of machine learning. Traditional methods for controlling vehicle emissions have limitations, highlighting the need for innovative solutions. As the study's main goal, we aim to explore machine learning's predictive capabilities in forecasting emission levels, assess its effectiveness in real-time monitoring, and investigate its potential for optimizing emission reduction strategies. Our focus is on reviewing existing literature and case studies. This is important because it helps us provide valuable insights for policymakers, urban planners, and regulatory authorities.

II. MACHINE LEARNING FOR EMISSION PREDICTION

A. Utilizing Diverse Data Sources for Accurate Emission Prediction

Machine learning uses diverse data sources to predict emissions accurately. Machine learning excels in handling large and varied datasets unlike traditional methods, which often rely on limited data and simplistic models. This capability enables it to effectively integrate various types of information, as illustrated in Fig. 1.

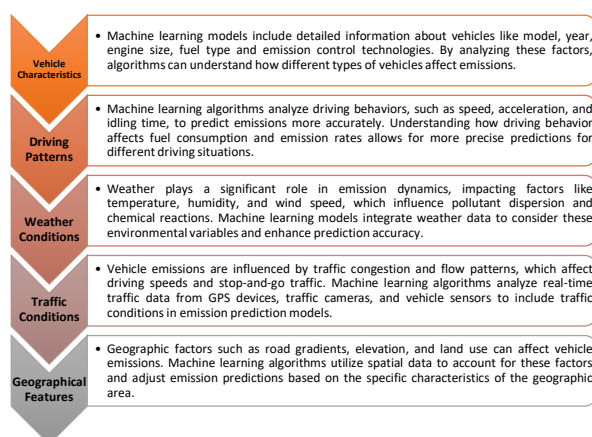

Fig. 1 Integration of Data Sources for Emission Prediction Using Machine Learning

By using a wide range of data sources, machine learning can make better predictions about vehicle emissions [24], [25]. This helps policymakers and urban planners create specific plans to reduce emissions and improve air quality, matching the needs of different areas and driving situations.

B. Role of machine learning in analyzing sensor data and detecting pollution events

In environmental monitoring, machine learning is critical in analyzing sensor data and identifying pollution events in real time. Sensor networks, IoT devices, and remote sensing technologies generate large volumes of data on air quality parameters like nitrogen dioxide (NO₂), carbon monoxide (CO), particulate matter (PM), and ozone (O₃) levels, making manual analysis challenging due to the volume and complexity of this data. However, machine learning algorithms offer a powerful solution for processing and analyzing these large-scale sensor data streams, enabling automated detection of pollution events and anomalies. Machine learning performs key functions like pattern recognition, anomaly detection, event prediction, and adaptive learning.

Machine learning algorithms specialize in pattern recognition, enabling them to identify deviations from typical operating conditions in sensor data, which may signify pollution events. By analyzing historical data, these algorithms can differentiate between normal fluctuations in air quality and abnormal spikes or patterns indicative of pollution [26].

Anomaly detection is a critical function that machine learning algorithms perform in environmental monitoring. These algorithms are designed to identify abnormal or unexpected observations in sensor data, which could indicate various issues, such as sudden changes in pollutant concentrations, unusual weather conditions, or equipment malfunctions. By automatically identifying these anomalies, machine learning algorithms enable timely intervention and corrective actions to mitigate potential environmental risks, ensuring the safety and well-being of societies [27], [28].

Furthermore, machine learning models can forecast pollution events based on patterns observed in sensor data and environmental conditions. These models can predict the timing and location of pollution events by analyzing historical data and considering predictive factors such as weather forecasts and traffic patterns. This enables proactive measures to be taken to reduce their impact [29], [30].

In addition, adaptive learning is a crucial feature of machine learning algorithms. They continuously refine their models using incoming data and feedback. As sensor data changes, these models dynamically adjust their parameters and refine predictions to accommodate changing environmental conditions and emerging pollution trends [31], [32].

Overall, Machine learning is vital in detecting pollution events and advancing environmental management. Machine learning automates the analysis of sensor data for timely pollution detection,

proactive intervention, and informed decision-making for air quality improvement and public health protection.

C. Case studies demonstrating the effectiveness of machine learning in emission prediction.

Machine learning (ML) is crucial in predicting and managing vehicle emissions using data analytics to optimize vehicle performance and minimize environmental impact. It contributes to emission modeling, real-time onboard monitoring, traffic management, component optimization, predictive maintenance, and emission control strategies in vehicle emissions prediction. ML algorithms have been successfully applied in various case studies to predict vehicle emissions accurately. These case studies demonstrate the effectiveness of machine learning in emission prediction across different contexts and provide valuable insights into its practical applications. Here are a few notable examples:

In their study, Subramaniam and Yusof [33] aimed to contribute to mitigating poor air quality in urbanizing cities by developing a model that accurately predicts CO₂ emissions from vehicles based on dynamic travel behavior. They employ an ensemble machine learning technique and integrate substantial data from laboratory tests and standard driving cycle patterns to enhance prediction accuracy. This model can potentially aid urban transportation planners in devising more effective strategies to reduce the current carbon footprint. Concurrently, Yap and Karri [34] created a two-stage predictive model for emissions using neural networks specifically tailored for scooters. Their model successfully forecasted CO, CO₂, HC, and O₂ emissions with remarkable accuracy. The optimization of the layer-by-layer network demonstrated the highest precision, with prediction errors within the range of $\pm 5\%$. This study offers valuable insights into how engine process parameters influence tailpipe emissions for scooters and potentially for other types of vehicles. Moreover, Seo and Park [35] utilized artificial neural networks (ANNs) to forecast diesel vehicle CO₂, NO_x, and CO emissions. They used on-road testing data and six operational factors as inputs: speed, engine RPM, engine torque, coolant temperature, fuel/air ratio, and intake air mass flow. Their findings suggested that incorporating more parameters enhanced prediction accuracy. Specifically, engine torque and fuel/air ratio emerged as significant predictors for CO₂ emissions. Intake air mass flow rate and fuel/air ratio were deemed crucial for predicting NO_x and CO emissions, respectively. Furthermore, prediction accuracy varied across vehicle types, with those equipped with after-treatment devices exhibiting lower accuracy compared to their counterparts without such devices.

Xu et al. [36] analyzed vehicle emissions using three years of Hefei remote sensing data. They introduced a three-layer artificial neural network (ANN) model to predict exhaust emissions. Initially, they employed the adaptive-lasso algorithm to identify key factors from the emission data. After conducting principal component analysis and selecting the appropriate algorithm and architecture, they established the Back-Propagation neural network model with a 7-12-1 architecture as the optimal approach. Finally, they presented prediction results on the testing dataset, validating the potential of their method for predicting vehicle exhaust emissions. Additionally, Seo et al. [37] aimed to develop a road vehicle emission model by combining an artificial neural network (ANN) with a vehicle dynamics model. They trained the ANN using real-world driving data and found that engine speed and torque alone were sufficient for accurate CO₂ prediction. The integrated model showed practicality and satisfactory prediction accuracy for road vehicle emissions, suggesting its potential for emission control strategies.

Azeez et al. [38] aimed to develop a hybrid model for predicting vehicular CO emissions in a Malaysian urban setting. Their approach integrated GIS and Artificial Neural Networks with feature selection to produce microscale prediction maps. Through the use of six traffic predictors and optimization techniques, they achieved an impressive 80.6% validation accuracy, providing valuable tools for simulating CO levels in congested areas. Concurrently, Yang et al. [39] focused on creating an artificial neural network (ANN) model to forecast the efficiency and emissions of gasoline engines. Their research showcased the model's ability to accurately predict power output, emissions, and combustion phasing indicators simultaneously. This highlights the potential of machine learning in optimizing and controlling engines, especially in hybrid vehicles. Furthermore, Khurana et al. [40] conducted a comprehensive review of methodologies for predicting engine emissions using machine learning techniques. They addressed the growing concern over

engine pollutants due to increased global automobile demand. Their paper summarized recent research from 2008 to 2020, focusing on artificial intelligence methodologies. They emphasized the cost efficiency of predictive modeling compared to traditional emission testing methods, and highlighted the rising prominence of advanced machine learning algorithms for generating emission data, pointing towards substantial research opportunities in this area.

These case studies highlight the effectiveness of machine learning in emission prediction across various applications and environments. By using advanced algorithms and big data analytics techniques, machine learning enables more accurate, timely, and actionable insights for emission control and air quality management.

III. REAL-TIME EMISSION MONITORING WITH MACHINE LEARNING

A. *Deployment of Sensor Networks and IoT Devices for Continuous Monitoring*

In modern environmental monitoring, deploying sensor networks and Internet of Things (IoT) devices has revolutionized how we monitor emissions in real-time. These networks consist of interconnected sensors strategically placed in urban areas, along roadways, and in industrial zones to continuously monitor air quality parameters such as pollutant concentrations, temperature, humidity, and atmospheric pressure.

These sensor networks and IoT devices provide high-resolution data, enabling more granular and comprehensive emissions monitoring than traditional monitoring methods. By leveraging the power of connectivity and data sharing, these networks facilitate real-time data transmission to centralized monitoring systems, allowing for the timely detection of pollution events and informed decision-making.

B. *Role of Machine Learning in Analyzing Sensor Data and Detecting Pollution Events*

Machine learning is critical in analyzing sensor data and detecting real-time pollution events. These algorithms are trained on vast amounts of historical data to recognize patterns, trends, and anomalies indicative of pollution events. It can detect deviations from normal operating conditions by continuously analyzing incoming sensor data streams, identifying pollution hotspots, and triggering alerts or notifications when pollution levels exceed predefined thresholds. Studies in this area have been summarized below.

Jain and Shah [41] aimed to enhance anomaly detection in smart cities through wireless sensor networks. They focused on analyzing real-time data from Aarhus, Denmark, specifically targeting air pollution levels to identify unhealthy locations based on the Air Quality Index (AQI). Employing machine learning techniques such as neural networks and Support Vector Machines, they achieved reliable accuracy and computational efficiency in MATLAB simulations, advancing the effectiveness of anomaly detection systems.

Ha et al. [42] explored recent advancements in machine learning (ML) technologies and their integration into smart sensor systems. They emphasized the utilization of ML algorithms to develop sophisticated models tailored for sensing applications, facilitating the fusion of diverse sensing modalities. By covering various practical sensing applications, including physical and chemical sensing and visual imaging sensing, they highlighted the practical benefits of ML-enabled smart sensor systems. Additionally, the authors provided insights into the challenges and opportunities for future smart sensing systems.

Iskandaryan et al. [43] conducted a comprehensive review of studies on air quality prediction in smart cities using machine learning algorithms based on sensor data. They observed an increasing adoption of advanced techniques, particularly in China, with a focus on predicting particulate matter with a diameter of 2.5 micrometers and considering external factors like weather conditions for more efficient prediction, contributing to improved air quality management strategies.

Jain et al. [44] developed spatiotemporal models for PM_{2.5}, NO₂, and CO concentrations utilizing a low-cost sensor network in Pittsburgh, Pennsylvania. They compared different modeling approaches, finding that machine learning-enabled land use models outperformed traditional land use regression models. Additionally, they employed wavelet decomposition to enhance model performance, especially for short-lived events, thereby improving the spatial resolution of air pollutant predictions and facilitating better mapping at high spatiotemporal resolution.

Ang and Seng [45] investigated the utilization of big sensor data systems in urban environments, leveraging advancements in Internet/Web/Network-of-Things technologies and large-scale wireless sensor systems. They summarized recent developments across various urban applications such as air pollution monitoring, assistive living, disaster management systems, and intelligent transportation. Their paper underscored the importance of extracting value from big sensor data systems and discussed techniques for data acquisition, cleaning, aggregation, modeling, and interpretation, offering insights into the future perspectives and challenges of sensor-based data systems in the big data era.

Ameer et al. [46] aimed to evaluate machine learning techniques for predicting air quality in smart cities. By conducting a comparative analysis of various regression models, the research sought to identify the most effective method for accurately predicting air quality while considering factors such as data size and processing time. The deployment of IoT-based sensors had transformed the approach to air quality prediction. The study performed pollution prediction using four advanced regression techniques and presented a comparative study to determine the best model. Through experiments with Apache Spark, the study evaluated Mean Absolute Error (MAE) and Root Mean Square Error (RMSE) to assess model performance. Additionally, the processing time of each technique was measured to find the best-fit model in terms of processing time and lowest error rate.

The studies highlighted the pivotal role of machine learning in analyzing sensor data and detecting pollution events. By leveraging sophisticated algorithms trained on historical data, machine learning enables real-time identification of patterns and anomalies associated with pollution. This capability enables continuous monitoring of pollution levels, pinpointing hotspots, and triggering alerts when pollution thresholds are breached. Overall, these findings emphasize the importance of machine learning in enhancing our comprehension of environmental conditions and enabling proactive measures to tackle pollution challenges in urban settings.

C. Examples of Successful Applications of Machine Learning in Real-Time Emission Monitoring

Several successful applications of machine learning in real-time emission monitoring have been demonstrated across various domains:

Shetty et al. [19] proposed an air pollution control model using machine learning and IoT techniques to address the increasing problem of automobile emissions surpassing standard values. Their model utilized real-time data and predictive analytics to monitor and control pollution levels. Sensors installed in vehicles measured pollutant levels, and a machine learning model predicted carbon monoxide values based on previous and current data. Notifications were sent to vehicle owners if emissions exceeded threshold values, and fuel supply to the engine was automatically cut off to control pollutant levels.

Le Cornec et al. [47] used machine learning to model diesel vehicle emissions, focusing on NO_x. They clustered vehicles based on emissions performance and evaluated three models for each cluster: look-up table, non-linear regression, and neural network. The non-linear regression model accurately predicted NO_x emissions, comparable to the neural network. These models offered a practical tool for policymakers to assess emissions and mitigation strategies.

Pushpam et al. [48] proposed an IoT-enabled model for vehicular air pollution monitoring, addressing the escalating problem of pollution from vehicles. Their approach integrated sensors to measure pollutants like CO and PM, alongside environmental factors such as temperature and humidity. Through a web-based application incorporating Google Maps API, users received suggestions for pollution-free routes based on real-time pollution data and distance. In their prediction analysis, they employed neural network Multi-Layer Perceptron and Support Vector Machine Regression algorithms, showing that the neural network achieved a 27.27% reduction in Mean Absolute Error compared to SVMR, indicating superior accuracy.

Ge et al. [49] developed a machine learning method to remotely monitor NO_x emissions from heavy-duty diesel vehicles (HDDVs) using OBD data streams. Their random forest (RF) model accurately identified abnormal emission states, outperforming logistic regression (LR). This approach demonstrated the potential of machine learning for real-time emission monitoring in HDDVs.

Srinivasan [50] introduced an IoT cloud-based real-time automobile monitoring system that utilized Raspberry Pi as the GPU. The system employed machine learning algorithms like K-Nearest Neighbor (KNN) and Naïve Bayesian to predict the condition and life expectancy of vehicle components such as the engine and coolant. Two data handling methods were proposed: Bluetooth Low Energy (BLE) for communication with the cloud database and a 4G dongle for direct transmission. The prototype seamlessly integrated BLE for OBD-II-Raspberry Pi communication and Wi-Fi for cloud interfacing, extracting various data points from a Ford car including speed, air pressure, temperature, CO2 emission, GPS coordinates, and fuel level indicator sensor readings. The system prioritized user-friendliness and interactivity, delivering real-time predictions to a mobile application.

These examples demonstrate the versatility and effectiveness of machine learning in real-time emission monitoring across diverse applications and environments. By using advanced algorithms and sensor technologies, machine learning enables more accurate, timely, and proactive emissions monitoring, leading to improved air quality and environmental sustainability.

IV. CHALLENGES AND FUTURE DIRECTIONS

Addressing challenges such as data quality and model interpretability is crucial for advancing machine learning applications in sustainable urban development. Emerging trends and opportunities for further research and development indicate the growing potential of machine learning in addressing urban challenges. The importance of continued innovation and collaboration underscores the need for collective efforts to leverage machine learning effectively for sustainable urban development.

Data quality and model interpretability must be addressed to maximize the effectiveness of machine learning-based mitigation strategies. Ensuring the accuracy and reliability of data inputs is crucial for training robust machine learning models. Additionally, improving the interpretability of machine learning models can enhance trust and transparency in decision-making processes, facilitating the adoption of mitigation strategies by stakeholders and policymakers.

Emerging trends such as integrating machine learning with advanced sensor technologies, Internet of Things (IoT) devices, and block chain technology present exciting opportunities for further research and development in emission reduction strategies. By leveraging these technologies, researchers can develop innovative real-time solutions for monitoring, analyzing, and mitigating vehicle emissions, leading to more sustainable and resilient urban environments.

Continued innovation and collaboration among researchers, policymakers, industry stakeholders, and the public are essential for leveraging machine learning effectively in addressing vehicle emissions and enhancing air quality. By fostering interdisciplinary partnerships and knowledge-sharing initiatives, we can accelerate the development and adoption of machine learning-based mitigation strategies, leading to tangible improvements in environmental sustainability and public health.

V. CONCLUSION

In conclusion, the application of machine learning models for predicting and reducing vehicle emissions represents a significant advancement in addressing air quality challenges in urban environments. Traditional approaches to emission control face limitations in accuracy and adaptability, making innovative solutions like machine learning essential. By harnessing advanced algorithms and analyzing large datasets, machine learning models offer the capability to forecast emission levels accurately, consider diverse factors influencing emissions, and optimize mitigation strategies.

The utilization of machine learning for real-time monitoring of vehicle emissions through sensor networks and IoT devices enables prompt interventions and informed decision-making. These technologies facilitate the detection of pollution events, identification of hotspots, and proactive measures to mitigate environmental impacts. Additionally, machine learning can optimize emission reduction strategies by identifying the most effective interventions based on historical data and predictive analytics.

Case studies showcasing the effectiveness of machine learning in emission prediction and real-time monitoring across various contexts underscore its practical applications and potential for improving air

quality. Successful applications in predicting CO₂ emissions, analyzing sensor data, and detecting pollution events demonstrate the versatility and efficacy of machine learning in addressing environmental challenges.

However, challenges such as data quality and model interpretability need to be addressed to maximize the effectiveness of machine learning-based mitigation strategies. Collaborative efforts among researchers, policymakers, industry stakeholders, and the public are crucial for advancing machine learning applications in sustainable urban development. By fostering innovation, interdisciplinary partnerships, and knowledge-sharing initiatives, we can leverage machine learning effectively to reduce vehicle emissions, enhance air quality, and promote environmental sustainability for future generations.

REFERENCES

- [1] D.-J. Hsu ve H.-L. Huang, "Concentrations of volatile organic compounds, carbon monoxide, carbon dioxide and particulate matter in buses on highways in Taiwan", *Atmos. Environ.*, c. 43, sy 36, ss. 5723-5730, Kas. 2009, doi: 10.1016/j.atmosenv.2009.08.039.
- [2] W.-W. Li, "Chapter 2 - Air pollution, air quality, vehicle emissions, and environmental regulations", içinde *Traffic-Related Air Pollution*, H. Khreis, M. Nieuwenhuijsen, J. Zietsman, ve T. Ramani, Ed., Elsevier, 2020, ss. 23-49. doi: 10.1016/B978-0-12-818122-5.00002-8.
- [3] K. Zhang ve S. Batterman, "Air pollution and health risks due to vehicle traffic", *Sci. Total Environ.*, c. 450-451, ss. 307-316, Nis. 2013, doi: 10.1016/j.scitotenv.2013.01.074.
- [4] G. Hoek vd., "Long-term air pollution exposure and cardio- respiratory mortality: a review", *Environ. Health*, c. 12, sy 1, s. 43, May. 2013, doi: 10.1186/1476-069X-12-43.
- [5] D. L. Buckeridge, R. Glazier, B. J. Harvey, M. Escobar, C. Amrhein, ve J. Frank, "Effect of motor vehicle emissions on respiratory health in an urban area.", *Environ. Health Perspect.*, c. 110, sy 3, ss. 293-300, Mar. 2002, doi: 10.1289/ehp.02110293.
- [6] W. Raza vd., "A review on the deteriorating situation of smog and its preventive measures in Pakistan", *J. Clean. Prod.*, c. 279, s. 123676, Oca. 2021, doi: 10.1016/j.jclepro.2020.123676.
- [7] I. Manisalidis, E. Stavropoulou, A. Stavropoulos, ve E. Bezirtzoglou, "Environmental and Health Impacts of Air Pollution: A Review", *Front. Public Health*, c. 8, Şub. 2020, doi: 10.3389/fpubh.2020.00014.
- [8] L. Chapman, "Transport and climate change: a review", *J. Transp. Geogr.*, c. 15, sy 5, ss. 354-367, Eyl. 2007, doi: 10.1016/j.jtrangeo.2006.11.008.
- [9] J. K. Stanley, D. A. Hensher, ve C. Loader, "Road transport and climate change: Stepping off the greenhouse gas", *Transp. Res. Part Policy Pract.*, c. 45, sy 10, ss. 1020-1030, Ara. 2011, doi: 10.1016/j.tra.2009.04.005.
- [10] T. Johnson, "Vehicular Emissions in Review", *SAE Int. J. Engines*, c. 6, sy 2, ss. 699-715, 2013.
- [11] T. V. Johnson, "Review of Vehicular Emissions Trends", *SAE Int. J. Engines*, c. 8, sy 3, ss. 1152-1167, 2015.
- [12] S. Bai ve C. Liu, "Overview of energy harvesting and emission reduction technologies in hybrid electric vehicles", *Renew. Sustain. Energy Rev.*, c. 147, s. 111188, Eyl. 2021, doi: 10.1016/j.rser.2021.111188.
- [13] J. Romm, "The car and fuel of the future", *Energy Policy*, c. 34, sy 17, ss. 2609-2614, Kas. 2006, doi: 10.1016/j.enpol.2005.06.025.
- [14] S. P. Beaton, G. A. Bishop, Y. Zhang, D. H. Stedman, L. L. Ashbaugh, ve D. R. Lawson, "On-Road Vehicle Emissions: Regulations, Costs, and Benefits", *Science*, c. 268, sy 5213, ss. 991-993, May. 1995, doi: 10.1126/science.268.5213.991.
- [15] V. Palma, G. Iervolino, ve E. Meloni, "Chapter 12 - Catalytic combustion for cleaner burning: Innovative catalysts for low temperature diesel soot abatement", içinde *Combustion Chemistry and the Carbon Neutral Future*, K. Brezinsky, Ed., içinde *Developments in Physical & Theoretical Chemistry*, Elsevier, 2023, ss. 345-382. doi: 10.1016/B978-0-323-99213-8.00002-3.
- [16] V. Havrysh, V. Nitsenko, I. Perevozova, T. Kulyk, ve O. Vasylyk, "Alternative Vehicle Fuels Management: Energy, Environmental and Economic Aspects", içinde *Advanced Energy Technologies and Systems I*, A. Zaporozhets, Ed., içinde *Studies in Systems, Decision and Control*, Cham: Springer International Publishing, 2022, ss. 91-115. doi: 10.1007/978-3-030-85746-2_5.
- [17] S. A. Shaheen ve T. E. Lipman, "Reducing Greenhouse Emissions and Fuel Consumption: Sustainable Approaches for Surface Transportation", *IATSS Res.*, c. 31, sy 1, ss. 6-20, Oca. 2007, doi: 10.1016/S0386-1112(14)60179-5.
- [18] K. Ropkins vd., "Real-World Vehicle Exhaust Emissions Monitoring: Review and Critical Discussion", *Crit. Rev. Environ. Sci. Technol.*, c. 39, sy 2, ss. 79-152, Oca. 2009, doi: 10.1080/10643380701413377.
- [19] C. Shetty, B. J. Sowmya, S. Seema, ve K. G. Srinivasa, "Chapter Eight - Air pollution control model using machine learning and IoT techniques", içinde *Advances in Computers*, c. 117, 1 c., P. Raj ve P. Evangeline, Ed., içinde *The Digital Twin Paradigm for Smarter Systems and Environments: The Industry Use Cases*, vol. 117., Elsevier, 2020, ss. 187-218. doi: 10.1016/bs.adcom.2019.10.006.

- [20] E. Prezioso, F. Giampaolo, C. Mazzocca, A. Bujari, V. Mele, ve F. Amato, "Machine Learning Insights for Behavioral Data Analysis Supporting the Autonomous Vehicles Scenario", *IEEE Internet Things J.*, c. 10, sy 4, ss. 3107-3117, Şub. 2023, doi: 10.1109/JIOT.2021.3118834.
- [21] I. Malik ve W. A. Khattak, "Enhancing Urban Health: Machine Learning Applications in Environmental Management", *Int. J. Sustain. Infrastruct. Cities Soc.*, c. 8, sy 1, Art. sy 1, Oca. 2023.
- [22] C. X. Hui, G. Dan, S. Alamri, ve D. Toghraie, "Greening smart cities: An investigation of the integration of urban natural resources and smart city technologies for promoting environmental sustainability", *Sustain. Cities Soc.*, c. 99, s. 104985, Ara. 2023, doi: 10.1016/j.scs.2023.104985.
- [23] T. M. Ghazal, M. K. Hasan, M. Ahmad, H. M. Alzoubi, ve M. Alshurideh, "Machine Learning Approaches for Sustainable Cities Using Internet of Things", içinde *The Effect of Information Technology on Business and Marketing Intelligence Systems*, M. Alshurideh, B. H. Al Kurdi, R. Masa'deh, H. M. Alzoubi, ve S. Salloum, Ed., içinde *Studies in Computational Intelligence*, Cham: Springer International Publishing, 2023, ss. 1969-1986. doi: 10.1007/978-3-031-12382-5_108.
- [24] A. M. Howlader, D. Patel, ve R. Gammariello, "Data-driven approach for instantaneous vehicle emission predicting using integrated deep neural network", *Transp. Res. Part Transp. Environ.*, c. 116, s. 103654, Mar. 2023, doi: 10.1016/j.trd.2023.103654.
- [25] Y. Xia vd., "Rapid assessments of light-duty gasoline vehicle emissions using on-road remote sensing and machine learning", *Sci. Total Environ.*, c. 815, s. 152771, Nis. 2022, doi: 10.1016/j.scitotenv.2021.152771.
- [26] D. Bhamare ve P. Suryawanshi, "Review on Reliable Pattern Recognition with Machine Learning Techniques", *Fuzzy Inf. Eng.*, c. 10, sy 3, ss. 362-377, Tem. 2018, doi: 10.1080/16168658.2019.1611030.
- [27] A. B. Nassif, M. A. Talib, Q. Nasir, ve F. M. Dakalbab, "Machine Learning for Anomaly Detection: A Systematic Review", *IEEE Access*, c. 9, ss. 78658-78700, 2021, doi: 10.1109/ACCESS.2021.3083060.
- [28] S. Omar, A. Ngadi, ve H. H. Jebur, "Machine Learning Techniques for Anomaly Detection: An Overview", *Int. J. Comput. Appl.*, c. 79, sy 2, ss. 33-41, Eki. 2013, doi: 10.5120/13715-1478.
- [29] A. Mohammadshirazi vd., "Predicting airborne pollutant concentrations and events in a commercial building using low-cost pollutant sensors and machine learning: A case study", *Build. Environ.*, c. 213, s. 108833, Nis. 2022, doi: 10.1016/j.buildenv.2022.108833.
- [30] D. A. Wood, "Long-term atmospheric pollutant emissions from a combined cycle gas turbine: Trend monitoring and prediction applying machine learning", *Fuel*, c. 343, s. 127722, Tem. 2023, doi: 10.1016/j.fuel.2023.127722.
- [31] A. Singh, S. Miller, ve M. Brinkley, "Lowering Carbon Foot-Print by Increasing Operational Efficiency Using Adaptive Machine Learning", program adı: SPE Annual Technical Conference and Exhibition, OnePetro, Eyl. 2022. doi: 10.2118/210008-MS.
- [32] A. Vaughan ve S. V. Bohac, "Real-time, adaptive machine learning for non-stationary, near chaotic gasoline engine combustion time series", *Neural Netw.*, c. 70, ss. 18-26, Eki. 2015, doi: 10.1016/j.neunet.2015.04.007.
- [33] N. Subramaniam ve N. Yusof, "Modelling of CO2 Emission Prediction for Dynamic Vehicle Travel Behavior Using Ensemble Machine Learning Technique", içinde *2021 IEEE 19th Student Conference on Research and Development (SCoReD)*, Kas. 2021, ss. 383-387. doi: 10.1109/SCoReD53546.2021.9652757.
- [34] W. K. Yap ve V. Karri, "Emissions predictive modelling by investigating various neural network models", *Expert Syst. Appl.*, c. 39, sy 3, ss. 2421-2426, Şub. 2012, doi: 10.1016/j.eswa.2011.08.091.
- [35] J. Seo ve S. Park, "Optimizing model parameters of artificial neural networks to predict vehicle emissions", *Atmos. Environ.*, c. 294, s. 119508, Şub. 2023, doi: 10.1016/j.atmosenv.2022.119508.
- [36] Z. Xu, Y. Kang, ve W. Lv, "Analysis and prediction of vehicle exhaust emission using ANN", içinde *2017 36th Chinese Control Conference (CCC)*, Tem. 2017, ss. 4029-4033. doi: 10.23919/ChiCC.2017.8027988.
- [37] J. Seo, B. Yun, J. Park, J. Park, M. Shin, ve S. Park, "Prediction of instantaneous real-world emissions from diesel light-duty vehicles based on an integrated artificial neural network and vehicle dynamics model", *Sci. Total Environ.*, c. 786, s. 147359, Eyl. 2021, doi: 10.1016/j.scitotenv.2021.147359.
- [38] O. S. Azeez, B. Pradhan, ve H. Z. M. Shafri, "Vehicular CO Emission Prediction Using Support Vector Regression Model and GIS", *Sustainability*, c. 10, sy 10, Art. sy 10, Eki. 2018, doi: 10.3390/su10103434.
- [39] R. Yang vd., "An Artificial Neural Network Model to Predict Efficiency and Emissions of a Gasoline Engine", *Processes*, c. 10, sy 2, Art. sy 2, Şub. 2022, doi: 10.3390/pr10020204.
- [40] S. Khurana, S. Saxena, S. Jain, ve A. Dixit, "Predictive modeling of engine emissions using machine learning: A review", *Mater. Today Proc.*, c. 38, ss. 280-284, Oca. 2021, doi: 10.1016/j.matpr.2020.07.204.
- [41] R. Jain ve H. Shah, "An anomaly detection in smart cities modeled as wireless sensor network", içinde *2016 International Conference on Signal and Information Processing (ICoNSIP)*, Eki. 2016, ss. 1-5. doi: 10.1109/ICONSIP.2016.7857445.
- [42] N. Ha, K. Xu, G. Ren, A. Mitchell, ve J. Z. Ou, "Machine Learning-Enabled Smart Sensor Systems", *Adv. Intell. Syst.*, c. 2, sy 9, s. 2000063, 2020, doi: 10.1002/aisy.202000063.
- [43] D. Iskandaryan, F. Ramos, ve S. Trilles, "Air Quality Prediction in Smart Cities Using Machine Learning Technologies Based on Sensor Data: A Review", *Appl. Sci.*, c. 10, sy 7, Art. sy 7, Oca. 2020, doi: 10.3390/app10072401.
- [44] S. Jain, A. A. Presto, ve N. Zimmerman, "Spatial Modeling of Daily PM2.5, NO2, and CO Concentrations Measured by a Low-Cost Sensor Network: Comparison of Linear, Machine Learning, and Hybrid Land Use Models", *Environ. Sci. Technol.*, c. 55, sy 13, ss. 8631-8641, Tem. 2021, doi: 10.1021/acs.est.1c02653.

- [45] L.-M. Ang ve K. P. Seng, "Big Sensor Data Applications in Urban Environments", *Big Data Res.*, c. 4, ss. 1-12, Haz. 2016, doi: 10.1016/j.bdr.2015.12.003.
- [46] S. Ameer *vd.*, "Comparative Analysis of Machine Learning Techniques for Predicting Air Quality in Smart Cities", *IEEE Access*, c. 7, ss. 128325-128338, 2019, doi: 10.1109/ACCESS.2019.2925082.
- [47] C. M. A. Le Cornec, N. Molden, M. van Reeuwijk, ve M. E. J. Stettler, "Modelling of instantaneous emissions from diesel vehicles with a special focus on NOx: Insights from machine learning techniques", *Sci. Total Environ.*, c. 737, s. 139625, Eki. 2020, doi: 10.1016/j.scitotenv.2020.139625.
- [48] "IoT Enabled Machine Learning for Vehicular Air Pollution Monitoring | IEEE Conference Publication | IEEE Xplore". Eriřim: 13 Mart 2024. [Çevrimiçi]. Eriřim adresi: <https://ieeexplore.ieee.org/abstract/document/8822001>
- [49] Y. Ge *vd.*, "Machine Learning-Aided Remote Monitoring of NOx Emissions from Heavy-Duty Diesel Vehicles Based on OBD Data Streams", *Atmosphere*, c. 14, sy 4, Art. sy 4, Nis. 2023, doi: 10.3390/atmos14040651.
- [50] A. Srinivasan, "IoT Cloud Based Real Time Automobile Monitoring System", içinde *2018 3rd IEEE International Conference on Intelligent Transportation Engineering (ICITE)*, Eyl. 2018, ss. 231-235. doi: 10.1109/ICITE.2018.8492706.



Utilizing Machine Learning for Accurate Estimation of Dam Reservoir Fluctuations

Elif Cesur^{*}, Merve Nur Durmuş¹, Güher Türkan²

¹ Industrial Engineering / Faculty of Engineering and Natural Sciences, Istanbul Medeniyet University, Turkey

² Industrial Engineering / Faculty of Engineering and Natural Sciences, Istanbul Medeniyet University, Turkey

* elif.karakaya@medeniyet.edu.tr

Abstract – The water levels in the dams supplying water to Istanbul are gradually decreasing, prompting the need for measures to prevent a potential water crisis. Predicting future water levels is crucial for effective planning and management. Machine learning, a branch of artificial intelligence, offers a powerful tool for analyzing large datasets and making accurate predictions. In our water level forecasting, we utilized a comprehensive set of parameters, including temperature, perceived temperature, dew, humidity, snowfall, wind speed, sea level pressure, cloud cover, visibility, solar radiation, solar energy, UV index, and precipitation. This study focuses on using machine learning techniques to estimate water levels in Istanbul's dams. In this study, we employed various methodologies including Decision Tree Regression, Random Forest Regression, Support Vector Regression, and utilized the Pycaret AutoML library. These approaches were implemented and evaluated to ascertain their effectiveness in predicting water levels. Initially, we conducted individual comparisons of three algorithms. However, upon integrating the AutoML library, we discovered that the linear regression model demonstrated superior performance compared to the others.

Keywords – Dam Reservoir, Machine Learning, Water Management, Estimation, Automl

I. INTRODUCTION

Water is the fundamental source of life and living organisms. Proper management of water resources, which cannot be replaced by any natural resource, is necessary for the continuity of life. Approximately 2.5% of the world's water resources are freshwater sources. However, only 10% of these freshwater sources are usable. With such a low percentage of usable freshwater, humans construct various structures to make the most out of water resources. Among these structures, dams are the most significant. Dams are water structures built to regulate water usage, prevent floods, and harness energy. A significant portion of the water available for human use comes from water masses created by dams. Climate change-induced drought brings water scarcity issues. Due to increasing temperatures and decreasing rainfall, the reservoir levels in dams supplying water to Istanbul are decreasing day by day. According to published reports, Turkey is among the countries experiencing water stress. By the 2040s, water scarcity is expected to become a serious issue. Measures and efforts are being taken to prevent the chronic water issue from turning into a water crisis in Istanbul. Predicting water levels in advance is crucial for taking necessary measures. Improvements in water supply for Istanbul, the city with the highest population density in Turkey, will be one of the most important steps taken. Accurate predictions of dam water consumption and forecasts related to water should be made to take preventive measures and necessary actions.

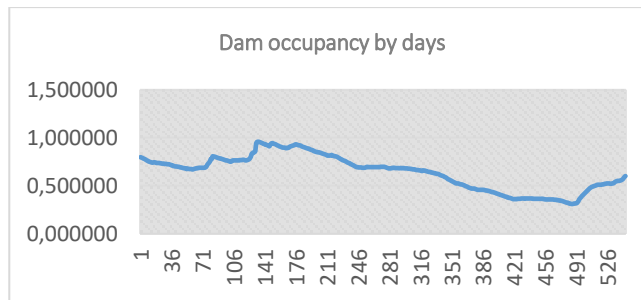

Fig.1 Example of analysis made on data

With the advancement of technology, the potential of artificial intelligence tools is increasing in today's world. The basic principle of artificial intelligence is to mimic how humans perceive and react to the world and then surpass them. Artificial intelligence, supported by a variety of automatic learning capabilities recognizing models in data to make predictions possible, performs well in prediction tasks. In this study, machine learning methods will be used to analyze factors affecting water levels, reasons for increases and decreases in reservoir levels, and the relationship between dam occupancy. The data set used in the research consists of daily data covering the years 2020-2023 obtained from ISKI and Istanbul Metropolitan Municipality (IBB). The data set includes various factors affecting the reservoir occupancy, such as rainfall, temperature, perceived temperature, wind, humidity, snowfall amount, snow depth, and water volume. This comprehensive data set has been preprocessed to make it suitable for machine learning. Machine learning algorithms such as Decision Tree Regression, Random Forest Regression, and Support Vector Regression have been used. Automatic Machine Learning (AutoML) method has been applied to identify higher-performance machine learning methods. With AutoML, all algorithms are tested for data sets, and the most suitable algorithm for dam data sets is determined with performance measurement values (RMSE, R-squared).

II. MATERIALS AND METHOD

This study has been conducted on the subject of predicting water levels in dams using machine learning algorithms. The research scope was narrowed down to investigations using AutoML (Automatic Machine Learning). Various studies have applied machine learning or, more broadly, artificial intelligence in dams. Upon reviewing these studies, the main idea is to monitor the current behavior of the dam and predict its future behavior in terms of water level. The common ground in this study is again to monitor the current conditions of the dam and predict future behaviors by interpreting them with machine learning.

A literature review reveals numerous studies based on prediction in dams. These studies cover various aspects such as water level prediction[1], detection of existing leakages, pavement prediction using artificial neural networks [2], examination of the structural conditions of dams[3], and prediction of flow levels using machine learning[4]. While many studies in the literature focus on factors influencing reservoir occupancy such as rainfall, temperature, and evaporation, our study also investigates parameters obtained daily such as UV index, solar energy, dew, and pressure, and their correlation with reservoir occupancy.

Upon examining AutoML studies in the literature, it's observed that there aren't many academic studies in this regard. Automatic machine learning is still a relatively fresh method under development. Therefore, in the studies conducted, the use of AutoML tools and packages is often described[5]. In this study, these libraries are also mentioned in the methodology section. Additionally, while previous studies usually focused on a single dam, our dataset includes all dams located in Istanbul. Furthermore, it's observed that a single method is generally used in machine learning studies. In our study, models run using both machine learning algorithms and the PyCaret library are compared, and analysis is visualized using the AutoViz library.

A. Machine Learning

Machine learning is the programming of computers to learn from past data experiences. It is a subset of artificial intelligence. Machine learning equips computers with the ability to learn, eliminating the need for explicit programming to teach new information. Instead, computers can automatically establish relationships between data and experiences acquired from large datasets.

Two separate methods were employed in the study. Firstly, machine learning algorithms were utilized, followed by the application of AutoML.

Support Vector Regression is one of the supervised machine learning methods used for solving non-linear regression problems. It aims to create a high-dimensional space plane suitable for the problem at hand. In other words, it attempts to find a high-dimensional space where a low-dimensional non-linear problem exhibits linear behavior. By doing so, the problem behaves linearly on this hyperplane. With the regression model it constructs on this hyperplane, it predicts the dataset. The mathematical representation is as follows: $f(x)=\sum w\phi(x)+b$. The basic representation of Support Vector Regression is shown in the graph below, where ε values indicate the deviation of the model.

Decision Tree Regression is one of the supervised machine learning methods used to predict the target value of continuous feature datasets. This method is used when many parameters are effective in decision-making. The features in the dataset form the nodes of the tree. Each node contains a threshold value. Each internal node represents a decision based on the threshold value. Each value in the dataset reaches a leaf value by passing through these nodes. Each leaf point reached by the data constitutes a prediction or a possible value. The main goal of this model is for each data point to reach an accurate leaf value by passing through the correct node points.

Random Forest Regression performs modeling using multiple decision trees. In each tree formation, random data is drawn from the dataset, resulting in decision trees dependent on different datasets due to this randomness. A generalized prediction value is obtained using predictions from each tree. In other words, each tree's classification is considered, and dominant classifications are selected collectively. With its ensemble modeling nature, this method is more advanced and can be generalized compared to decision tree regression. The number of datasets and the number of trees are two main parameters affecting the performance of this method.

B. AutoML

To achieve quality machine learning, it is essential to obtain healthy data first. Then, these data are processed with appropriate preprocessing steps and analyzed with the correct methods. Having sufficient equipment in machine learning-based studies is crucial for these processes to proceed correctly. Therefore, with the development of Automatic Machine Learning, which reduces human influence, ease of machine learning processes and optimum performance have been targeted. AutoML can be thought of as a large and versatile optimization problem in terms of its mathematical aspect. This problem is expressed as a solutions space that can produce predictions for a dataset based on a certain computation budget without human intervention. In the AutoML process, the success of the process depends on adjustable parameters called hyperparameters, which allow control of the model training process. Through these parameters, the machine's performance is aimed to be optimized during the analysis process.

Auto-Sklearn is a Python-based AutoML package built on top of Scikit-learn. This package fully automates algorithm selection and HP tuning processes, taking them from the user. The Auto-sklearn package applies important feature extraction methods such as binary representation of categorical variables, standardization of numerical features, and principal component analysis to the features of the dataset. This package was used in this study.

PyCaret is a library that embraces automatic machine learning. It is a Python version of the Caret package designed to simplify standard tasks in classification and regression datasets.

With its user-friendly interface, it provides advantages in machine learning by facilitating advantageous applications. This open-source machine learning library, where the workflow is automated, is an alternative library where long lines of work are simplified and used.

When using PyCaret, the following processes take place:

1. Data acquisition.
2. Environment setup.
3. Model creation.
4. 4. Fine-tuning the model.
5. Obtaining graphs from the model.
6. Obtaining predictions from the model.
7. Measuring the model's performance.

III. DISCUSSION

In the study, the RMSE and R^2 performance metrics of the Support Vector Regression (SVR) model were obtained. Subsequently, the modeling of the method was conducted.

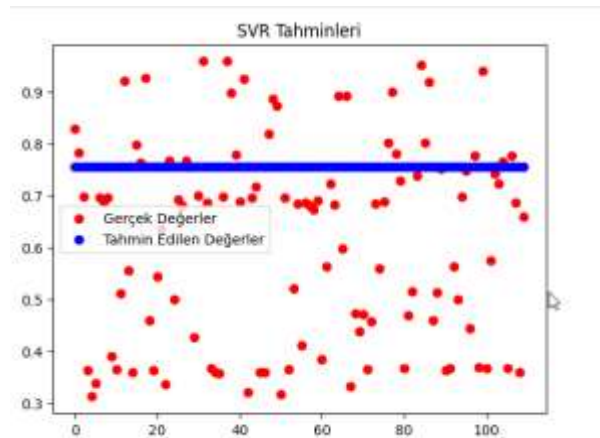

Fig.2 SVR Prediction Modelling

The study also involved obtaining the RMSE and R^2 performance metrics for the Decision Tree Regression (DTR) model. The modeling of the decision tree was performed, and the effects of parameters were determined based on the model.

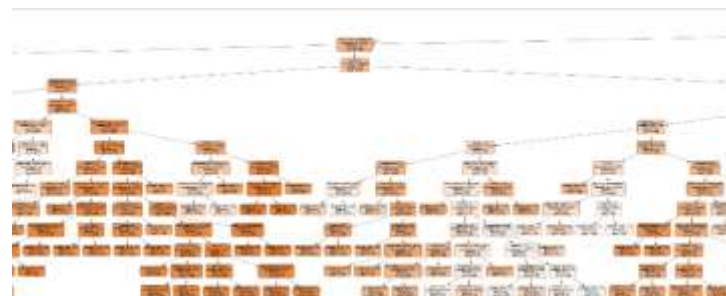

Fig.3 DTR Modelling

Similarly, the RMSE and R^2 performance metrics for the Random Forest Regression (RFR) model were obtained in the study. Modeling was conducted by selecting one tree from the generated decision trees.

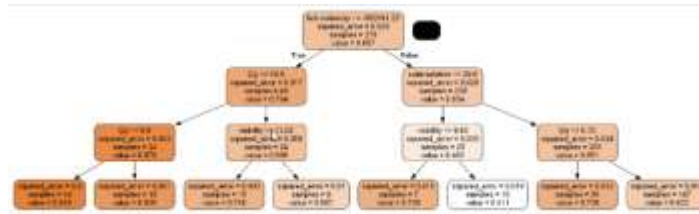

Fig.4 RFR Modeling

The findings obtained through the AutoML method in the study are presented below. As shown in the output below, when comparing the models, the linear regression model was determined to be the best model.

Table 1. Comparison Table of Model Performance Values

	Model	MAE	MSE	RMSE	R2	RMSLE	MAPE	TT (Sec)
lr	Linear Regression	0.0041	0.0000	0.0047	0.9997	0.0033	0.0261	0.8350
omp	Orthogonal Matching Pursuit	0.0041	0.0000	0.0046	0.9997	0.0032	0.0262	0.1600
lrr	Bayesian Ridge	0.0041	0.0000	0.0047	0.9997	0.0033	0.0261	0.1890
huber	Huber Regressor	0.0041	0.0000	0.0048	0.9997	0.0033	0.0270	0.1940
et	Extra Trees Regressor	0.0042	0.0000	0.0053	0.9996	0.0037	0.0486	0.4440
gbr	Gradient Boosting Regressor	0.0043	0.0000	0.0053	0.9996	0.0036	0.0507	0.2960
rf	Random Forest Regressor	0.0047	0.0000	0.0063	0.9994	0.0045	0.0984	0.4510
dt	Decision Tree Regressor	0.0068	0.0001	0.0091	0.9988	0.0064	0.1043	0.1980
lar	Least Angle Regression	0.0062	0.0001	0.0075	0.9987	0.0054	0.0471	0.2530
lightgbm	Light Gradient Boosting Machine	0.0062	0.0001	0.0116	0.9981	0.0091	0.2912	0.3300
ridge	Ridge Regression	0.0103	0.0002	0.0127	0.9978	0.0093	0.1921	0.6650
adaboost	AdaBoost Regressor	0.0157	0.0004	0.0193	0.9946	0.0132	0.2971	0.2840
par	Passive Aggressive Regressor	0.0342	0.0017	0.0408	0.9771	0.0206	0.7074	0.1850
lasso	Lasso Regression	0.2340	0.0766	0.2756	-0.0253	0.1922	3.9835	0.1740
en	Elastic Net	0.2340	0.0766	0.2756	-0.0253	0.1922	3.9835	0.2680
lar	Lasso Least Angle Regression	0.2340	0.0766	0.2756	-0.0253	0.1922	3.9835	0.1880
dummy	Dummy Regressor	0.2340	0.0766	0.2756	-0.0253	0.1922	3.9835	0.2000

In the AutoML study, it was found that the best model was the linear regression model. The performance evaluation table of the linear regression model with 10-fold cross-validation.

Table 2.Linear Regression Performance Evaluation

	MAE	MSE	RMSE	R2	RMSLE	MAPE
Fold						
0	0.0047	0.0000	0.0052	0.9995	0.0034	0.0123
1	0.0035	0.0000	0.0041	0.9998	0.0027	0.0096
2	0.0046	0.0000	0.0052	0.9996	0.0036	0.0207
3	0.0049	0.0000	0.0053	0.9996	0.0038	0.0194
4	0.0039	0.0000	0.0044	0.9998	0.0032	0.0498
5	0.0039	0.0000	0.0046	0.9998	0.0031	0.0172
6	0.0042	0.0000	0.0047	0.9997	0.0033	0.0573
7	0.0030	0.0000	0.0039	0.9998	0.0027	0.0121
8	0.0050	0.0000	0.0055	0.9995	0.0038	0.0164
9	0.0037	0.0000	0.0043	0.9998	0.0030	0.0570
Mean	0.0041	0.0000	0.0047	0.9997	0.0033	0.0272
Std	0.0006	0.0000	0.0005	0.0001	0.0004	0.0184

Upon examining the results of the AutoML study, it was determined that the linear regression model exhibited the best performance. The performance of the models was compared with manually run models, and the error rates were found to be similar.

IV. DISCUSSION

The findings of this study evaluate the impact of machine learning methods in predicting dam water levels in Istanbul. The analyses show that the Random Forest Regression model has higher predictive power compared to other methods. However, studies carried out with the AutoML method have revealed that the linear regression model exhibits the best performance. These results show that artificial intelligence techniques can be used effectively in predicting dam water levels in Istanbul and that automatic methods such as AutoML can facilitate processes such as model selection and hyperparameter tuning. Study; It aims to contribute to a new perspective in estimating dam water levels by using AutoML and machine learning methods, which are increasingly common day by day.

V. CONCLUSION

After processing two years of daily data, machine learning algorithms including Decision Tree Regression, Random Forest Regression, and Support Vector Regression methods were applied. A total of 546 data points were used, with 436 as training data and 110 as test data. The performance of each model was compared by calculating the Root Mean Squared Error (RMSE) and the coefficient of determination (R^2 - R-squared).

Table 3. Performance Values of the Models Used

Used Model	RMSE	R^2
Desicion Tree Regressor(DTR)	0.00277	0,9986
Random Tree Regressor(RFR)	0.01724	0,9932
Destev Vektör Regresyonu (SVR)	0.23857	0,0711

Upon examining the performances, it was determined that the Random Forest Regression method had a higher predictive power compared to the other two methods. To identify machine learning techniques that would yield higher performance outputs than these three methods, the Automatic Machine Learning (AutoML) method was applied.

Upon reviewing the results of the AutoML study, it was found that the Linear Regression model exhibited the best performance. The performance of this model was compared with manually run models, and the error rates were found to be close.

Table 4. Performance Values of the Linear Regression Model

Model	MAE	MSE	RMSE	R2	RMSLE	MAPE
Linear Regression	0.0041	0.000	0.0047	0.9997	0.0033	0.0261

REFERENCES

- [1] Onur Fatih, "Baraj Gölü Doluluk Tahmininde Bulanık Mantık Yaklaşımı Fatih Onur Yüksek Lisans Tezi Jeodezi Ve Fotogrametri Anabilim Dalı," 2015.
- [2] Z. Kareem, A. Abu, S. Danışman, And E. Keskin, "Süleyman Demirel Üniversitesi Fen Bilimleri Enstitüsü Yapay Sinir Ağları İle Dibi Barajı'nın Seviye Tahmini Yüksek Lisans Tezi İnşaat Mühendisliği Anabilim Dalı Isparta-2018," 2018.
- [3] Kalkan Ebru, "Karadeniz Teknik Üniversitesi Fen Bilimleri Enstitüsü İnşaat Mühendisliği Anabilim Dalı Kemer Barajların Yapısal Davranışlarının Belirlenmesi Amacıyla Ölçeklendirme Ve Regresyona Dayalı Mühendislik Yazılımının Geliştirilmesi Yüksek Lisans Tezi," Trabzon, 2017.
- [4] Şander Emrah And Keskin Tülay Ekemen, "Ovacuma (Bartın) Çayı Akımının Makina Öğrenmesi Yardımıyla Tahmin Edilmesi Ve Bartın Bahçecik Yeraltı Barajı Beslenimlerinin Hesaplanması 2023 Yüksek Lisans Tezi İnşaat Mühendisliği Emrah Şander."
- [5] N. Sarangpure, V. Dhamde, A. Roge, J. Doye, S. Patle, And S. Tamboli, "Automating The Machine Learning Process Using Pycaret And Streamlit," In *2023 2nd International Conference For Innovation In Technology, Inocon 2023*, Institute Of Electrical And Electronics Engineers Inc., 2023. Doi: 10.1109/Inocon57975.2023.10101357.



Anomaly Detection Implementation with Digital Twin Approach Using Isolation Forest

Elif Cesur*, Aleyna Yemekci ²

¹ Industrial Engineering / Faculty of Engineering and Natural Sciences, Istanbul Medeniyet University, Turkey

² Industrial Engineering / Faculty of Engineering and Natural Sciences, Istanbul Medeniyet University, Turkey

* elif.karakaya@medeniyet.edu.tr

Abstract – The concept of digital twins, introduced into our lives with Industry 4.0, is becoming increasingly widespread. With digital twins, the interaction between the virtual and physical environments can be monitored in real time, allowing for iterative operations and obtaining insights from data collected by sensors. Moreover, maintenance activities in businesses have started to become more prevalent to prevent potential time and financial losses, predict and prevent failures in advance through predictive maintenance processes.

On the other hand, anomaly detection allows deviations and behaviors from the norm to be identified, enabling the prediction of potential failures and the implementation of necessary measures. This helps to prevent high maintenance costs and time losses such as machine downtimes, thereby increasing system reliability. In this study, anomaly detection was performed using data collected from three sensors installed on an elevator to contribute to the literature. While performing anomaly detection, the Isolation Forest (iForest) algorithm was selected, based on its use within the AutoML library called Pycaret. iForest is one of the unsupervised algorithms used in anomaly detection. It is theoretically based on decision trees and has a distance-based detection approach. It is used to isolate outlier values in the dataset to detect anomalies. As a result of the study, we gathered 106,421 data points, with 5,580 identified as outliers by the iForest algorithm, and examined, revealing the conditions and value ranges in which anomalies were detected. These value ranges provide an opportunity to interpret the optimum levels at which parameters should be maintained to prevent anomalies from occurring.

Keywords - Digital Twin, Anomaly Detection, Predictive Maintenance, Isolation Forest, Smart Manufacturing

I. INTRODUCTION

With Industry 4.0, the concepts of big data, artificial intelligence, blockchain, the Internet of Things, and digital twins have emerged and become widespread. With these developments, the importance of data and information has increased significantly. The importance of making data meaningful, analyzing it, and using it in decision processes is understood.

Digital twins can be used in the life cycle of product development, design, operation, maintenance, service, and production because they can monitor the interaction of the virtual environment and the physical environment in real time, allow iterative operations, and have complete information on the data [1].

Keeping pace with the continuously evolving Industry 4.0 technologies enables businesses to generate more effective results. Recent studies indicate an increasing use of digital twins for modeling objects in a manner consistent with the real world, detecting anomalies, and creating maintenance plans.

The transformation of data into meaningful insights and progress in decision and production processes based on this information contributes to a higher quality production process. Therefore, the use of digital twins, enabling real-time data collection, has gained significance in today's context.



Figure 1. Digital twin technology [2]

Anomalies are data points that stand out among other data in a dataset, deviating from the typical behavior of the data set as outlier values. These data points exhibit differences from the behavioral patterns of the data group. Anomaly detection is considered the problem of identifying patterns in outlier data that do not conform to the expected behavior of the data [3],[4].

Anomaly detection is the observation of outlier data points that deviate from the general pattern of data in data analysis. The reason for this is that anomaly detection ensures avoidance of potential adverse events. While anomaly detection used to be done manually in the past, today, machine learning algorithms are employed to achieve better results

The study involves an anomaly detection application using an elevator dataset. In the first step, the dataset was analyzed through data preprocessing steps. The second step involved examining correlation values and visualizing the data. Thirdly, anomaly detection was performed. In this stage, anomaly detection models from the AutoML library, specifically the Pycaret library, were explored, and the iForest algorithm was selected and applied.

After the application, the data identified as anomalies by the iForest algorithm was visually represented, and the values were interpreted.

II. LITERATURE REVIEW

The literature addresses maintenance costs and methods developed to reduce these costs. Predictive maintenance plays a significant role in reducing maintenance costs and downtime.

Digital twin applications are implemented to prevent, take preventive measures, and predict errors before they occur. The models created as a result of these studies are transformed into usable and interpretable information through data analyses.

Emerging anomaly detection algorithms are noteworthy for predicting potential issues in advance.

Wang and his team aimed to better understand deep learning-based anomaly detection systems. In their study, they began by explaining the anomaly detection techniques used before deep learning structures and later provided a discussion on the strategies employed by modern deep learning-based anomaly detection techniques, which utilize high technology extensively, to overcome challenges faced by previous traditional algorithms [7].

In the study conducted by Hsieh and others, an algorithm proposed to detect abnormalities in intelligent manufacturing systems using real-time data collected simultaneously from devices in manufacturing systems was examined. To identify limited and irregular abnormal data in multivariate sensor datasets obtained from the production line, an unsupervised real-time anomaly detection algorithm based on

autoencoders was applied. The results demonstrated a success rate of 90% in anomaly detection for this proposed algorithm [8].

III. MATERIALS AND METHOD

ISOLATION FOREST ALGORITHM

The Isolation Forest is one of the unsupervised algorithms used in anomaly detection. It is theoretically based on decision trees and employs distance-based detection [5]. It is utilized to isolate and identify anomalies by isolating outlier values within the dataset.

Algorithm Steps:

1. A random feature is selected.
2. Maximum and minimum values are determined for the selected feature.
3. A random value is chosen within these bounds.
4. An outlier is isolated by examining data points above and below the selected value. If a data point is below the chosen threshold, it branches left; if it is above, it branches right.

This process continues recursively until each data point is completely isolated or reaches maximum depth if defined.

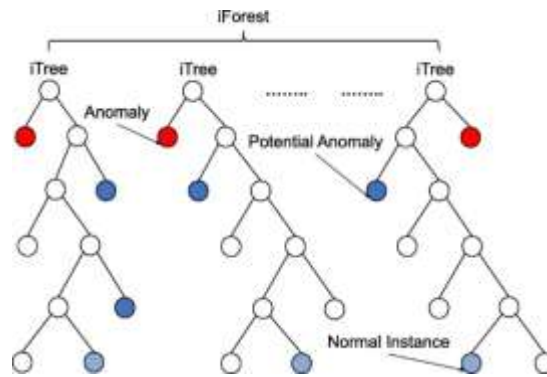

Figure 2. iForest structure

As in other anomaly detection methods, an anomaly score is calculated. During scoring, each data point is passed through all the previously trained trees. An 'anomaly score' based on the depth of the tree required to reach that point is assigned to each data point. This score is a combination of the depths obtained from each isolation tree.

If the obtained score is close to 1, it is labeled as anomalous; if it is less than 0.5, it is considered normal. An assignment of -1 or 0 is given to data points identified as anomalies, while normal data points receive a label of 1. When constructing the algorithm, parameter values are specified for the dataset to achieve optimal performance. These parameters can be adjusted to enhance the algorithm's overall effectiveness.

IV. RESULTS

An anomaly detection application has been implemented on the dataset created using the digital twin. The dataset consists of 3 columns and 112,002 rows.

Data preprocessing steps were applied to organize the dataset, and corruptions were detected. Punctuation errors and values perceived as dates were filtered and corrected to enhance the dataset's integrity.

Statistical measures, including the mean, standard deviation, minimum, maximum, and quartile values, have been determined for each column in the dataset.

	ball-bearing	humidity	vibration
count	112001.000000	112001.000000	112001.000000
mean	46.275452	74.224140	28.773674
std	19.041852	0.684711	24.517300
min	16.933000	72.399000	2.000000
25%	29.651000	73.914000	8.000000
50%	43.348000	74.212000	21.390000
75%	63.997000	74.731000	39.685000
max	93.744000	75.400000	99.995000

Figure 3. Data set statistical values

The correlation between columns of the dataset has been examined.

	ball-bearing	humidity	vibration
ball-bearing	1.000000	-0.101482	-0.105080
humidity	-0.101482	1.000000	0.153545
vibration	-0.105080	0.153545	1.000000

Figure 4. Data set correlation values

The iForest algorithm, which is an unsupervised anomaly detection algorithm, has been applied.

	ball-bearing	humidity	vibration	Anomaly	Anomaly_Score
11025	68.771004	72.873001	23.632999	0	-0.044215
108249	19.351000	73.582001	35.742001	0	-0.099915
36580	61.960999	74.940002	84.105003	1	0.004932
45444	46.558998	75.208000	8.556000	0	-0.098836
56096	43.313999	73.922997	54.463001	0	-0.078350
12646	67.820999	74.565002	8.030000	0	-0.126815
71832	36.612999	73.925003	68.737999	0	-0.082642
5236	77.114998	72.607002	21.691000	0	-0.058317
109381	20.677000	74.014000	22.033001	0	-0.117088

Figure 5. Output of the iForest algorithm

The t-SNE (t-distributed Stochastic Neighbor Embedding) plot has been utilized to visualize the high-dimensional dataset obtained as a result of applying the trained model.

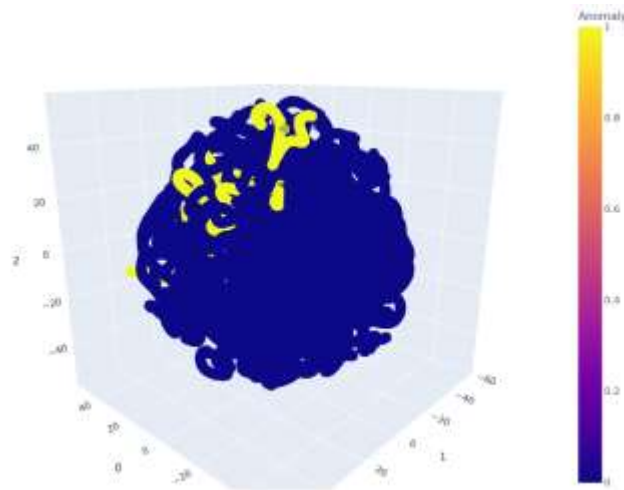

Figure 6. t-SNE Plot

The values identified as anomalies through the iForest algorithm have been visualized.

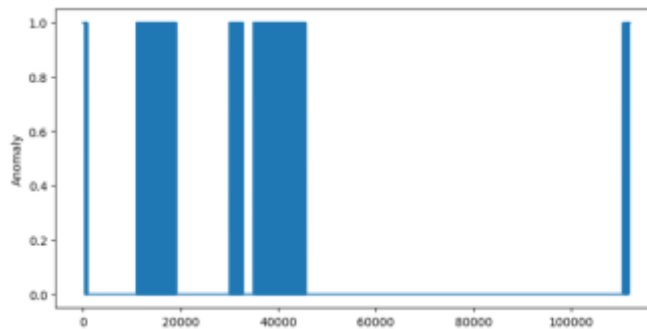

Figure 7. Distribution of values identified as anomalies by the iForest algorithm

Correlation analysis has been conducted to observe the relationship between the results and the columns. In the study, an anomaly detection application was implemented on the digital twin dataset. The 'elevator' dataset, obtained by creating a digital twin through, was utilized for this purpose. Anomaly detection was performed using the Pycaret libraries, specifically employing the unsupervised anomaly detection algorithm isolation forest. In the initial stage, noise in the dataset was eliminated. Subsequently, data preprocessing steps were taken to obtain information about the dataset as a whole. The data was visualized, and upon examining correlation ratios, it was observed that the internal correlations within the dataset were relatively low. This indicates that the features of the dataset have minimal influence on each other.

As a result of the algorithm, 106,421 data points were identified as normal, while 5,580 data points were classified as anomalies. A subsequent correlation analysis was performed with the anomaly results. According to the correlation analysis of the iForest algorithm, anomalies showed a positive relationship with the 'vibration' column at a rate of 43%.

Upon examining the values identified as anomalies by the algorithms, it became possible to predict when anomalies would occur based on which values the features approached. Looking at the relationship of the columns with the data identified as anomalies in Figure 9, it was observed that the 'humidity' column had no significant impact on anomalies. On the other hand, the variability between the 'ball-bearing' and 'vibration' columns was found to be influential on anomalies.

It is anticipated that optimizing parameter values will enhance the efficiency of the applied model, leading to a significant reduction in costs based on predictive maintenance activities.

	ball-bearing	humidity	vibration	iforest anomaly
ball-bearing	1	-	-	-
humidity	0,101482074	1	-	-
vibration	0,105079682	0,153545	1	-
iforest anomaly	0,200021017	0,109895	0,434265	1

Figure 8. Correlation analysis for anomaly values

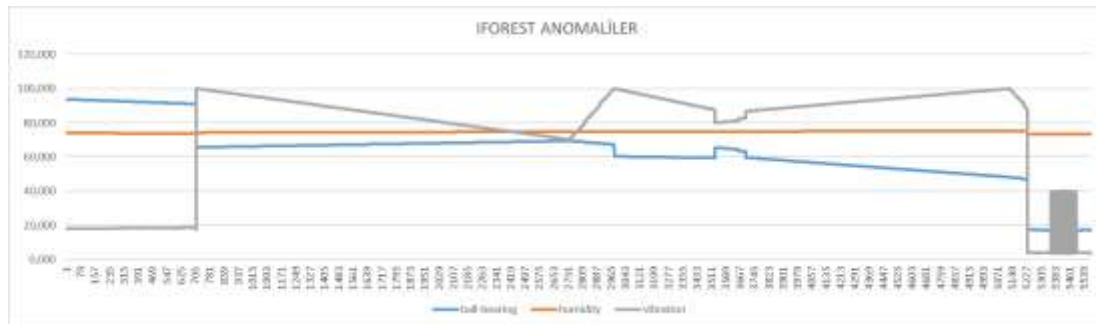

Figure 9. Interaction of anomalies with column value

V. CONCLUSION

The significance of technologies evolving with Industry 4.0 is rapidly increasing in today's world. One of these technologies is the digital twin, which enables real-time monitoring of interactions between virtual and physical environments, facilitates easier observation of changes, and allows for more effective analysis of errors. It is observed that with digital twin technology, it is possible to analyze potential fault situations of any object or system that can be simultaneously tracked in real-time, detect anomalies in advance, and thereby prevent or mitigate losses.

In this study, anomaly detection was implemented for the 'elevator' dataset, generated from sensor data installed in the elevator. The goal was to contribute to the literature by introducing an anomaly detection application, enabling proactive intervention to anticipate potential malfunction scenarios in elevators and thereby preventing both high maintenance costs and time losses.

Analyzing potential failure scenarios and proactively detecting anomalies for any object or system that can be simultaneously tracked with digital twin technology has become increasingly crucial. This capability allows for preventing or minimizing losses effectively.

This study contributes to the literature by applying the iForest algorithm, one of the anomaly detection methods, to detect anomalies.

REFERENCES

- [1] S. M. Metev and V. P. Veiko, *Laser Assisted Microtechnology*, 2nd ed., R. M. Osgood, Jr., Ed. Berlin, Germany: Springer-Verlag, 1998.
- [2] J. Breckling, Ed., *The Analysis of Directional Time Series: Applications to Wind Speed and Direction*, ser. Lecture Notes in Statistics. Berlin, Germany: Springer, 1989, vol. 61.
- [3] S. Zhang, C. Zhu, J. K. O. Sin, and P. K. T. Mok, "A novel ultrathin elevated channel low-temperature poly-Si TFT," *IEEE Electron Device Lett.*, vol. 20, pp. 569–571, Nov. 1999.
- [4] M. Wegmuller, J. P. von der Weid, P. Oberson, and N. Gisin, "High-resolution fiber distributed measurements with coherent OFDR," in *Proc. ECOC'00*, 2000, paper 11.3.4, p. 109.
- [5] R. E. Sorace, V. S. Reinhardt, and S. A. Vaughn, "High-speed digital-to-RF converter," U.S. Patent 5 668 842, Sept. 16, 1997.
- [6] (2002) The IEEE website. [Online]. Available: <http://www.ieee.org/>

- [7] M. Shell. (2002) IEEEtran homepage on CTAN. [Online]. Available: <http://www.ctan.org/tex-archive/macros/latex/contrib/supported/IEEEtran/>
- [8] *FLEXChip Signal Processor (MC68175/D)*, Motorola, 1996.
- [9] "PDCA12-70 data sheet," Opto Speed SA, Mezzovico, Switzerland.
- [10] A. Karnik, "Performance of TCP congestion control with rate feedback: TCP/ABR and rate adaptive TCP/IP," M. Eng. thesis, Indian Institute of Science, Bangalore, India, Jan. 1999.
- [11] J. Padhye, V. Firoiu, and D. Towsley, "A stochastic model of TCP Reno congestion avoidance and control," Univ. of Massachusetts, Amherst, MA, CMPSCI Tech. Rep. 99-02, 1999.
- [12] *Wireless LAN Medium Access Control (MAC) and Physical Layer (PHY) Specification*, IEEE Std. 802.11, 1997.



Implementing Demand Forecasting with Machine Learning and Time Series Algorithms: A Case Study of a Weapon Manufacturer

Elif Cesur^{*}, Berra Can Şaylan², Zübeyde Dide Karaman³

¹ Endüstri Mühendisliği / Mühendislik ve Doğa Bilimleri, İstanbul Medeniyet Üniversitesi, Türkiye

² Endüstri Mühendisliği / Mühendislik ve Doğa Bilimleri, İstanbul Medeniyet Üniversitesi, Türkiye

³ Endüstri Mühendisliği / Mühendislik ve Doğa Bilimleri, İstanbul Medeniyet Üniversitesi, Türkiye

* elif.karakaya@medeniyet.edu.tr

Abstract – Efficient organization of warehouse activities, cost-effective stock management, improved customer satisfaction, and timely fulfillment of orders are critical aspects of supply chain management. Traditional methods often struggle to accurately predict the fluctuating and diverse demands faced by growth-oriented firms, resulting in persistent uncertainty in demand forecasting. In contrast, leveraging machine learning algorithms with time series data facilitates achieving superior forecasting accuracy, especially for demands characterized by such variability. These models can effectively align predictions with the underlying data patterns, providing a viable solution for addressing uncertain demand fluctuations in warehouse operations.

This study is centered around enhancing warehouse operations within a factory that manufactures weapons, where the existing warehouse management approach has proven inadequate due to escalating production volumes. The dataset used for this analysis comprises warehouse entry records spanning the past three years of factory operations. Employing machine learning algorithms with time series analysis, demand forecasting was performed on the collected data. Subsequently, the predictive performance metrics were compared to ascertain the effectiveness of different techniques. The machine learning methodologies and time series algorithms utilized in this research were implemented using the PyCaret library in the Python programming language.

An examination of the prediction methodologies applied in this study revealed that the best MAPE ratio achieved was 0.0061 with the Extra Trees approaches utilizing time series analysis consistently outperforming traditional methods in terms of forecasting accuracy and performance.

Keywords - Time Series, Machine Learning Algorithms, Warehouse Activities, PyCaret, AutoML

1. INTRODUCTION

Managing demand uncertainty is important for production planning and control. Failure to manage demand uncertainty leads to unmet consumer demand and expectations. Research has shown that companies unable to meet demand and expectations have been observed to go bankrupt.[1] Accurate demand forecasts are of great importance for companies. Demand forecasting aims to maximize profit, minimize losses, and manage inventory. [7]

During demand forecasting, data preprocessing steps are applied to the data being forecasted to increase its real market suitability and ensure good performance.

Outliers and extreme values are removed, and data that eliminate the effects of promotions or shortages are used in demand forecasting. [4] Factors that do not affect the general character of demand and incorrect entries should also be removed from the dataset used for forecasting. The diverse and fluctuating nature of demand leads traditional methods to generate estimates containing unrealistic values and exhibit poor performance. In order to prevent this, machine learning algorithms are proposed that will analyze the data and produce the correct model for prediction.

Most of the estimation methods can be divided into two main categories, causal and historical data-based methods.[8] When data contain seasonal and trending components, forecasts are generated by incorporating time series analysis into machine learning algorithms

In this study, we are working on a factory where the current warehouse management approach is insufficient due to increasing production volumes. Our goal for this factory is to improve warehouse operations. Demand estimation was carried out using machine learning algorithms by taking warehouse entry data records covering the last three years of factory operations. MAE (Mean Absolute Error), MAPE (Mean Absolute Percentage Error), RMSE (Root Mean Square Error), and TT (Sec) (total Time (Seconds)) values were examined to assess the accuracy of machine learning algorithm-developed models for demand forecasting in 2024. In addition to regression models, time series analyses were performed for prediction, taking into account the probability that the dataset includes seasonality and trend components. The performances of the two obtained models were compared.

The data obtained from demand forecasting aim to be used in simulation applications for inventory management, to reduce uncertainties in the supply chain, and to create potential scenarios for warehouse management.

2. MATERIAL AND METOT

2.1. MACHINE LEARNING ALGORITHMS

Machine learning is a branch of artificial intelligence, and systems that can learn from data and be improved through experience are designed using computers. [16] Machine Learning utilizes different algorithms to solve data problems in a manner suitable for the characteristics of the dataset. [11]. Machine learning algorithms can provide appropriate features for the current prediction scenario and process large data sets. Therefore, they do not impose assumptions on the data. This applies both to the data creation process and to the scope of the model.[9]

Research has shown that companies unable to meet demand and expectations have been observed to go bankrupt.[1] Smart components in the supply chain such as demand forecasting and inventory management are crucial to the existence of a retail business. However, many unique characteristics in retail operations challenge traditional operations research solutions and create significant difficulties [6]. Machine learning algorithms, recommended as an alternative to statistical methods for making predictions due to the inadequacy of traditional methods, are used to forecast demand data characterized by intermittency and instability. [14] Machine learning is seen as a promising tool that can be used to develop demand forecasting models that are better than the methods currently used in supply chain management. [1]

2.2. TIME SERIES ANALYSIS

Time Series Analysis focuses on analyzing and modeling linear dynamic systems using statistical methods. It formulates various linear models, discusses their theoretical properties, and explores connections among stochastic dynamic models.[3]

Time series analysis refers to a series of tasks that aim to extract meaningful information from data sequentially sorted over time. The information obtained can be used not only to understand the behavior of past data but also to forecast future data. Widely known examples of time series analysis include classification, decoupling, prediction, and anomaly detection.[5]

The design of a time series prediction model focuses on implementing algorithms. Under certain assumptions about the data, the model captures the relevant variables and summarizes them in a mathematical framework that represents the current dynamic relationships.[12]

The time series analysis method is used to understand the effects of temporality in demand forecasting. [16] With time series analysis, the presence of seasonal and trend components in the dataset can be determined and these trends and seasonal components can be decomposed from the dataset to provide an accurate forecast according to the characteristics of the dataset.

2.3. LIBRARIES AND TOOLS

AutoML, also known as automated machine learning, is the process of automating the machine learning process. It delivers much faster results compared to machine learning by automating complex tasks. It automatically performs optimization on the hyperparameters required to improve the model's performance. AutoML provides multiple results at once by automatically obtaining feature engineering, model selection, hyperparameter tuning, and ensemble modeling stages, which are used in machine learning. The results obtained are either the best results that can be achieved in machine learning or improved versions of the obtained results. AutoML tools aim to make machine learning accessible to non-machine learning experts (domain experts), increase the efficiency of machine learning, and accelerate machine learning research.[10]

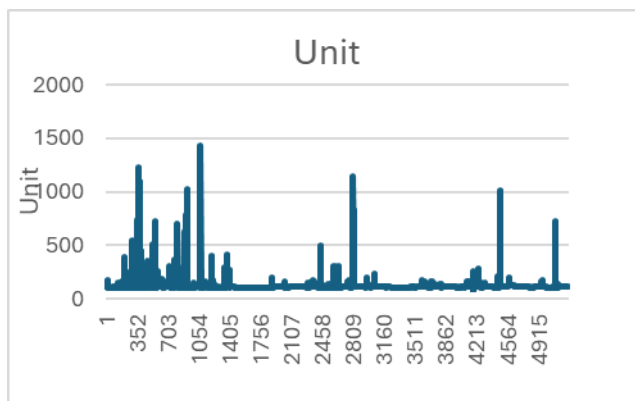

Figure 3.1: Distribution of the Menstrual Variable

The PyCaret library is a low-code automatic machine learning (AutoML) framework that can be used for classification and prediction purposes, allowing us to achieve fast results by automating processes. [2] Designing an automatic machine learning system using the PyCaret library can generally simplify the work of users by reducing some of the processes involved in machine learning. [13]

3. CASE STUDY

3.1. DATA PREPROCESSING

This study was conducted using warehouse entry data from a weapon-producing factory for the years 2020-2023, as the current warehouse management approach became inadequate due to increasing production

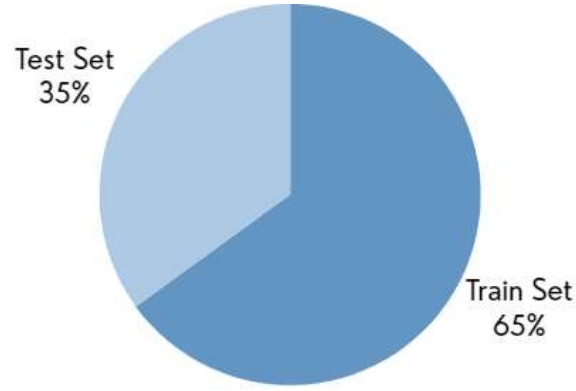

Figure 3.2 .1 Percentage of Dividing the Data Set into Training and Testing

volumes. The data consists of 31,694 rows and 18 columns. The dataset was manually cleaned to remove incomplete, duplicate, non-quantity-related, and erroneous data. From the remaining data, information about a product with the highest sales and importance for the warehouse operations of the factory was selected and demand forecasts were made based on this product data. After applying data preprocessing steps for demand forecasting, the data has been transformed into 5060 rows and 6 columns. The data graph is presented in Figure 1, the data summary in Table 3.1, and the first 4 rows of the data are shown in Table 3.2.

Table 3.1: Data Summary

	Yıl	Ay	Gün	Adet
count	5260,00	5260,00	5260,00	5260,00
mean	2021,32	5,91	15,64	123,18
std	1,03	3,41	9,01	58,94
min	2020,00	1,00	0,10	100,00
25%	2020,00	3,00	8,00	108,00
50%	2021,00	6,00	16,00	112,00
75%	2022,00	9,00	24,00	120,00
max	2023,00	12,00	31,00	1434,00

Table 3.2: First 4 Rows of The Data rows of the data

	Yıl	Ay	Gün	Adet
count	5260,00	5260,00	5260,00	5260,00
mean	2021,32	5,91	15,64	123,18
std	1,03	3,41	9,01	58,94
min	2020,00	1,00	0,10	100,00
25%	2020,00	3,00	8,00	108,00
50%	2021,00	6,00	16,00	112,00
75%	2022,00	9,00	24,00	120,00
max	2023,00	12,00	31,00	1434,00

Tablo3.2 Some samples of dataset

Yıl	Ay	Gun	Saat	UrunID	Adet
2020	1	2	14:25	1770	120
2020	1	2	14:25	1770	120
2020	1	2	14:25	1770	120
2020	1	2	14:25	1770	120

3.2. DEMAND FORECASTING WITH MACHINE LEARNING ALGORITHMS

The dataset has been divided into training and test sets in a 65-35 ratio to apply machine learning algorithms for prediction and to determine the performance of the applied model. Since the dataset has a fluctuating and varied behavior, it was desired to make predictions using machine learning algorithms. The PyCaret library was used to create and compare regression models that would predict based on the behavior of the dataset and provide the best results according to specific performance metrics.



Figure 3.1 Boxplot of the Unit Variable

	Model	MAE	RMSE	MAPE	TT (Sec)
lightgbm	Light Gradient Boosting Machine	16,6244	50,8970	0.1087	0.1100
catboost	CatBoost Regressor	15,1600	51,3268	0.0976	0.7000
rf	Random Forest Regressor	13,1300	51,8483	0.0799	0.0880
gbr	Gradient Boosting Regressor	19,0326	53,5328	0.1238	0.0400
et	Extra Trees Regressor	13,0080	53,7124	0.0803	0.0750
knn	K Neighbors Regressor	14,5110	53,3757	0.0863	0.0110
dt	Decision Tree Regressor	13,0222	54,5090	0.0791	0.0080
xgboost	Extreme Gradient Boosting	13,9570	54,7924	0.0879	0.2380
llar	Lasso Least Angle Regression	20,7060	57,1958	0.1318	0.0080
lasso	Lasso Regression	20,7060	57,1958	0.1318	0.0080
br	Bayesian Ridge	20,7252	57,2079	0.1320	0.0090
en	Elastic Net	20,6280	57,2250	0.1310	0.0070
lr	Linear Regression	20,7724	57,2091	0.1325	0.6730
ridge	Ridge Regression	20,7722	57,2091	0.1325	0.0090
lar	Least Angle Regression	20,7724	57,2091	0.1325	0.0080
omp	Orthogonal Matching Pursuit	20,7657	57,3098	0.1322	0.0090
dummy	Dummy Regressor	20,6451	57,4262	0.1307	0.0140
huber	Huber Regressor	15,4630	58,4246	0.0779	0.0120
par	Passive Aggressive Regressor	18,1098	58,6988	0.1025	0.0070
ada	AdaBoost Regressor	30,3086	69,1541	0.2282	0.0160

Figure 3.2.2 Performance Results of Regression Models

Demand forecasting was conducted using 22 different regression models. The error rates of the predictions based on performance metrics such as MAE (Mean Absolute Error), MAPE (Mean Absolute Percentage Error), RMSE (Root Mean Square Error), and TT (Sec) (Training Time in Seconds) are provided in Figure 3.2.1.

3.3. DEMAND FORECAST WITH TIME SERIES ANALYSIS

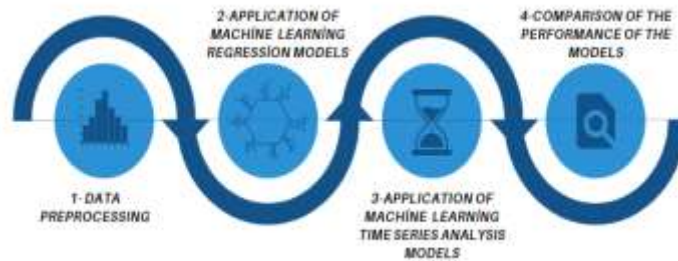

Figure 3.2 Method Flow Diagram

	MODEL	MAE	RMSE	MAPE	FI (SEC)
et_cds_d	Extra Trees w/ Cond.				
t	Deseasonalize & Detrending	0.8434	0.9596	0.0075	0.7660
dt_cds_d	Decision Tree w/ Cond.				
t	Deseasonalize & Detrending	1,2568	1,5568	0.0112	0.1240
rf_cds_dt	Random Forest w/ Cond.				
	Deseasonalize & Detrending	1,2896	1,4238	0.0115	5.222
knn_cds_dt	K Neighbors w/ Cond.				
	Deseasonalize & Detrending	1,6525	1,6584	0.0148	0.0920
en_cds_dt	Elastic Net w/ Cond.				
	Deseasonalize & Detrending	3,4503	3,7820	0.0308	0.1400
llar_cds_dt	Lasso Least Angular Regressor w/ Cond.				
	Deseasonalize & Detrending	3,4526	3,7807	0.0308	0.0600
lasso_cd	Lasso w/ Cond.				
s_dt	Deseasonalize & Detrending	3,4526	3,7807	0.0308	0.0620
br_cds_dt	Bayesian Ridge w/ Cond.				
	Deseasonalize & Detrending	3,4682	3,7920	0.0310	0.0600
omp_cds_dt	Orthogonal Matching Pursuit w/ Cond.				
	Deseasonalize & Detrending	3,5185	3,9617	0.0314	0.0580
lr_cds_dt	Linear w/ Cond.				
	Deseasonalize & Detrending	3,5890	3,8641	0.0320	0.2140
ridge_cd	Ridge w/ Cond.				
s_dt	Deseasonalize & Detrending	3,5889	3,8641	0.0320	0.0620
lightgbm_cds_dt	Light Gradient Boosting w/ Cond. Deseasonalize & Detrending	3,6504	3,9063	0.0326	0.3120
catboost_cds_dt	CatBoost Regressor w/ Cond. Deseasonalize & Detrending	3,6708	4,3767	0.0328	2.766
huber_cds_dt	Huber w/ Cond. Deseasonalize & Detrending	4,2796	4,6206	0.0382	0.1000
gbr_cds_dt	Gradient Boosting w/ Cond. Deseasonalize & Detrending	4,8154	5,3966	0.0430	1.652
xgboost_cds_dt	Extreme Gradient Boosting w/ Cond. Deseasonalize & Detrending	10,5823	15,3457	0.0945	1.182
grand_means	Grand Means Forecaster	11,2068	11,2068	0.1001	0.4720
stlf	STLF	12,6555	16,2450	0.1130	0.9760
ada_cds_dt	AdaBoost w/ Cond. Deseasonalize & Detrending	167,7665	171,1045	1,4979	0.2920

Figure 3.2.3 Performance Results of Machine Learning Algorithm Models with Time Series

Considering the error rates obtained, it was observed that the best prediction model created using regression models was the light gradient Enhancer machine model. To reduce the errors in the four performance metrics used, new prediction models were tested on the dataset. The next prediction models were also

created using the PyCaret library and included time series analysis models that evaluated trends and seasonality on demand within the prediction model. The performance rankings of the model containing 23 time series analyses for prediction are provided in Figure 3.2.

4. DISCUSSION

According to the findings of the research, time series characteristics with seasonal and trend-inclined components were observed in the data set. The errors in regression models formed by machine learning algorithms are much higher compared to models created using time series analysis. When comparing the accuracy values of the best model created with regression models, which is the Light Gradient Boosting Machine, and the model created with time series analysis, the Extra Trees with Conditional Deseasonalization and Detrending model stands out as having much better performance than other time series, except for the TT (sec) value. The term "conditional deseasonalization and detrending" mentioned in 21 out of 23 models built with time series analysis separates seasonal and trend components from the dataset, enabling the prediction of future values unaffected by seasonality and trend influences.

1. CONCLUSION

The research results involved obtaining warehouse entry data from a company engaged in weapon production and aiming to improve warehouse operations efficiency. This data spanned from 2020 to 2023 and was used to forecast demand for the year 2024, intending to be used as input for future studies. The studies in the literature were reviewed for the selection of the model to be developed for demand forecasting. The results obtained conclude that traditional methods are insufficient for similar fluctuating and diverse data sets.

Prediction models were created using machine learning algorithms and the PyCaret library in Python to obtain 22 regression models. Following that, the time series analysis method was used with the PyCaret library to understand the effects of temporality and causal factors in demand forecasting and to observe seasonal and trend changes. As a result, 23 time series models were generated. The lower MAE, RMSE, and MAPE results of the time series models compared to the regression models support the conclusion that demand forecasting involves seasonal and trend components. Using machine learning algorithms and time series analysis for demand forecasting will provide more accurate predictions that are suitable for real-world data.

5. REFERENCES

- [1] Aamer, A. M., Yani, L. P., & Priyatna, I. M. (2021). Data Analytics in the Supply Chain Management: *OPERATIONS AND SUPPLY CHAIN MANAGEMENT*.
- [2] Abdullah, F. B., Biswas, S., & Urba, R. (2021, June). Performance analysis of intrusion detection systems using the PyCaret machine learning library on the UNSW-NB15 dataset.
- [3] Analysis, T. S. (2007). *Henrik Madsen*. New York.
- [4] Cadavid, J. P., Lamouri, S., & Grabot, B. (2018, September 25). Trends in Machine Learning Applied to Demand & Sales. *HAL*.
- [5] Choi, K., Yi, J., Park, C., & Yoon, S. (2021, August 6). Deep Learning for Anomaly Detection in Time-Series Data: Review, Analysis, and Guidelines.
- [6] Deng, Y., Zhang, X., Wang, T., Wang, L., Zhang, Y., Wang, X., . . . Peng, X. (2023, 1 31). Alibaba Realizes Millions in Cost Savings Through Integrated Demand Forecasting, Inventory Management, Price Optimization, and Product Recommendations. *INFORMS Journal on Applied Analytics*.
- [7] G, S. F., & N, P. (2020, November 19). Machine Learning in Demand Forecasting - A Review.
- [8] Ghalekhondabi, I., Ardjmand, E., Weckman, G. R., & Young, W. A. (2017). An overview of energy demand forecasting methods. *Energy System*.
- [9] Huber, J., & Stuckenschmidt, H. (2020, December). Daily retail demand forecasting using machine learning with emphasis on calendric special days.
- [10] Karmaker, S. K., Hassan, M. M., & Smith, M. J. (2021, October 4). AutoML to Date and Beyond: Challenges and Opportunities. *ACM Computing Surveys*.

- [11]Mahesh, B. (2018, January). Machine Learning Algorithms - A Review. *International Journal of Science and Research (IJSR)*.
- [12]Parmezan, A. R., Souza, V. M., & Batista, G. E. (2019, May). Evaluation of statistical and machine learning models for time series prediction: Identifying the state-of-the-art and the best conditions for the use of each model. *Information Sciences*, s. 302-337.
- [13]Sihombing, D. J., Dexius, J. U., & Manurung, J. (2022). Design and Analysis of Automated Machine Learning (AutoML) in PowerBI Application Using PyCaret. *Science and Information Technology in Smart Administration (ICSINTESA), International Conference of*.
- [14]Spiliotis, E., Makridakis, S., Semenoglou, A.-A., & Assimakopoulos, V. (2020, September 16). Comparison of statistical and machine learning methods for daily SKU demand forecasting. *Operation Research*.
- [15]Verbesselt, J., Hyndman, R., Newnham, G., & Culvenor, D. (2010, January 15). Detecting trend and seasonal changes in satellite image time series. *Jan Verbesselt a, Rob Hyndman b, Glenn Newnham a, Darius Culvenor a*, s. 106-115.
- [16]What is The Machine Learning. (tarih yok). J. Bell içinde, *Pro Machine Learning Algorithms A Hands-On Approach to Implementing Algorithms in Python and R* (s. 1-5).



Gıda Teknolojisinde Yapay Zekâ Kullanımında Güncel Yaklaşımlar

Melikenur Türkol^{1*}, Nazan Tokatlı Demirok² ve Seydi Yıkılmış³

¹ Beslenme ve Diyetetik Bölümü / Sağlık Bilimleri Fakültesi, Haliç Üniversitesi, Türkiye

² Beslenme ve Diyetetik Bölümü / Sağlık Bilimleri Fakültesi, Tekirdağ Namık Kemal Üniversitesi, Türkiye

³ Gıda İşleme Bölümü / Çorlu Meslek Yüksekokulu, Tekirdağ Namık Kemal Üniversitesi, Türkiye

*(melikenurturkol@gmail.com)

Özet – Yapay zekâ teknolojisi sürdürülebilirlik çerçevesinde önemli bir araç olarak öne çıkmaktadır. Yapay zekâ, insan zekâsına benzer yeteneklere sahip bilgisayarlar aracılığıyla karar alma, öneriler sunma ve düşünme gibi işlevler gerçekleştirebilmektedir. Yapay zekâ programlaması veri toplama, algoritma oluşturma, doğru algoritmayı seçme ve sürekli olarak algoritmaları ayarlama gibi zihinsel yetkilere dayanmaktadır. Gıda endüstrisinde önemli rol oynayan bu teknoloji, çeşitli amaçlar için kullanılmaktadır. Amaçlar arasında modelleme, tahmin, kontrol, gıda kurutma, duysal değerlendirme ve kalite kontrolü bulunmaktadır. Bu alanda gıda endüstrisinde bilgi tabanlı uzman sistem, bulanık mantık (Fuzzy) tekniği, yapay sinir ağı tekniği (ANN), uyarlanabilir nöro bulanık çıkarım sistemi (ANFIS) tekniği yer almaktadır. Yapay zekânın öğrenme yaklaşımı, doğal dil işleme gibi uygulamaları kapsayarak insan zekâsını taklit etme amacı gütmektedir. Yaklaşımın temeli veri toplama, algoritma oluşturma ve sürekli olarak algoritmaları ayarlama gibi bilişsel becerilere dayanmaktadır. Tarım sektöründe, ön üretimden dağıtımına kadar olan tüm aşamalarda makine öğrenimi algoritmaları kullanılmaktadır. Ürün verimliliği, hastalık tespiti, üretim planlaması, gıda üretiminde ve tedarik zincirinde verimliliğin sağlanması, iş stratejilerinin geliştirilmesi vurgulanmaktadır. Tarım faaliyetlerinin verimliliğini arttırmaya yönelik etkili çözümler sunarak sürdürülebilirliğe de katkı sağlanmaktadır. Yapay zekâ teknolojisinin gıda sektöründeki öneminin anlaşılması üzerine araştırmacıların çalışmalarını bu yönde ilerletmesi beklenmektedir. Bu bildiride gıda teknolojisinde yapay zekâ kullanımında güncel yaklaşımlar derlenmiştir.

Anahtar Kelimeler – ANFIS, ANN, Fuzzy, Gıda Teknolojisi, Yapay Zekâ

I. GİRİŞ

Dünya nüfusunu beslemek için 2050 yılına kadar küresel gıda üretiminin %60 ile %110 arasında artırılması gerekmektedir [1]. Birleşmiş Milletler Gıda ve Tarım Örgütü (FAO), nüfusun 2050 yılında yaklaşık 9,1 milyara ulaşabileceğini belirtmiştir [2]. Hava ve iklim koşullarındaki değişiklikler su kıtlığını gündeme getirmekte, sürdürülebilir sistemlere olan ihtiyacı arttırmaktadır. Tarımsal üretkenlik anlayışından sürdürülebilir tarıma stratejik bir dönüşümün yapılması gerekmektedir. Verimli çözümler öngörebilmek, sürdürülebilirlik çerçevesinde kararların geliştirilmesine yardımcı olabilmek adına yapay zekâ teknolojisi kritik bir seçenektir [3]. Yapay zekâ, insan zekâsına özgü yeteneklerle donatılmış bilgisayarlardır; bunlar arasında bilgi edinme, öneriler sunma kararlar alma ve düşünme gibi beceriler bulunmaktadır [4].

II. YAPAY ZEKÂ ÖĞRENME YAKLAŞIMI

Yapay zekâ; bilgisayar sistemleri, robotik ve dijital ekipmanlar tarafından insan zekâsını ve yeteneklerini taklit eden bir yenilikçi araçtır. Doğal dil işleme (NLP) gibi uygulamalar, insan sözlü

iletişimini anlama, bilgisayar görüşü analogdan dijitale dönüşüm gibi çeşitli alanlara yayılmıştır. Konuşma tanıma ve uzman sistemler gibi uzmanlık alanları da içermektedir. Yapay zekâ kodlaması veri toplama, algoritmalar oluşturma, doğru algoritmayı seçme ve sürekli olarak algoritmaları ayarlama gibi bilişsel becerilere dayanmaktadır [5].

III. YAPAY ZEKÂ TEKNOLOJİSİ

Tarım tedarik zincirinin her aşamasında (ön üretim, üretim, işleme ve dağıtım), makine öğrenimi algoritmalarının kullanımı giderek artmaktadır. Ön üretimde, ürün verimi, toprak özellikleri ve sulama gereksinimlerinin tahmininde makine öğrenimi teknolojileri kullanılmaktadır. Üretim aşamasında hastalık tespiti ve hava tahmini gibi konularda, işleme aşamasında ise üretim planlamasının kaliteli ve güvenli olması için makine öğrenimi algoritmalarına başvurulmaktadır. Makine öğrenimi tarım endüstrisinde verimliliği arttırmak ve akıllı tarım uygulamalarını geliştirmek için önemli rol oynamaktadır [6,7].

IV. GIDA TEKNOLOJİSİNDE YAPAY ZEKÂ

Gıda ve içecek sektöründeki teknolojik ilerlemeler robotik, veri teknolojisi, yeni işleme teknikleri ve yeni uygulama alanları gibi unsurları içerecek şekilde geniş bir yelpazeyi kapsamaktadır [8]. Gıda endüstrisinde yapay zekâ uygulamalarının kullanımı giderek artmaktadır, bunun sebepleri arasında gıda sınıflandırma, parametre tahmini, kalite kontrolü ve gıda güvenliği gibi çeşitli faktörler yer almaktadır. Uzman sistemler, bulanık mantık, yapay sinir ağları (ANN), adaptif sinir bulanıklık çıkarım sistemi (ANFIS) ve makine öğrenimi gibi teknikler bu alanda yaygın olarak kullanılmaktadır [9–14].

Gıda Endüstrisinde Bilgi Tabanlı Uzman Sistem

Bilgi tabanlı sistem, çeşitli kaynaklardan alınan bilgi ve verileri kullanarak karmaşık sorunları çözmek için tasarlanmış bir tür bilgisayar programıdır. Bu sistem genellikle üç ana kategoriye ayrılmaktadır; uzman sistemler, bilgi tabanlı yapay zekâ ve bilgi tabanlı mühendislik. Endüstride sıkça kullanılan bir alt tür olan bilgi tabanlı uzman sistem, insan uzmanların karar verme yeteneklerini taklit edebilen kesin ve kolektif bir bilgisayar sistemidir [15].

Gıda Endüstrisinde Bulanık Mantık (Fuzzy) Tekniği

Zadeh tarafından 1965 yılında tanımlanan Fuzzy, insan zekâsının mükemmel karar alma yeteneğine dayanarak ve belirsiz, belirsiz ve muğlak verileri çözme yeteneğine odaklanarak geliştirilmiştir [16,17]. Bulanık küme teorisi, bir elemanın bulanık kümenin içindeki üyelik derecesinin $[0, 1]$ aralığında bir gerçek sayı olduğu şeklinde tanımlanmaktadır [18]. Bu denetleyici, inverter kontrol uygulamalarında en basit olanıdır ve diğer tüm akıllı denetleyiciler arasında yer almaktadır. Geleneksel denetleyicilere göre daha iyi bir performans sergilemekte; yanıt süresi, yerleşme süresi, parametre ve yük değişikliklerine duyarlılık ve sağlamlık açısından avantajlar sunmaktadır [19]. İkili ayırım, keskin bir sınırın iki sınıf arasında çizilmesi anlamına gelmektedir ve bu, köklü kartezyen geleneğin bir parçasıdır fakat bu geleneğin artık geçerliliğini yitirdiği edilmektedir. Bulanık mantığın önemli katkılarından biri, ikili ayırımdan derecelendirmeye, keskin sınırlardan çeşitliliğe, siyah-beyaz düşünceden gri tonlara doğru bir ilerleme sağlamasıdır [16].

Gıda Endüstrisinde Yapay Sinir Ağı Tekniği (ANN)

ANN, gıda endüstrisinde yaygın olarak kullanılan başka bir yapay zekâ ögesidir. İnsan beynini taklit etmek, öğrenme yoluyla bilgi kazanabilmek ve sinaptik ağırlıklar olarak bilinen sinir hücreleri arası

bağlantılar yoluyla bilgi işleyebilmek için tasarlanmıştır [20]. Bu teknik, girdi ve çıktı arasındaki karmaşık ilişkileri istatistiksel olarak öğrenebilme yeteneğine sahip olduğu için başarıyla kullanılmıştır [21].

Gıda Endüstrisinde Uyarlanabilir Nöro Bulanık Çıkarım Sistemi (ANFIS) Tekniği

Nöro-bulanık model, sinir ağlarının ve bulanık çıkarım sistemlerinin bir kombinasyonudur. Bu model, sinir ağlarının bulanık çıkarım sistemlerinin parametrelerini belirlemek için kullanılmaktadır [22]. Bulanık sistemler, açık ve anlaşılabilir bilgiyle ilgilenirken sinir ağları örtülü bilgiyle ilgilenmektedir. Bu nedenle bulanık mantık, bu iki yaklaşımın avantajlarını birleştirmektedir. Sinir ağlarının genelleme yeteneğini geliştirmekte, eğitim verilerinin sınırlarının ötesinde daha güvenilir çıktılar sağlayabilmekte, böylece ekstrapolasyon gerektiğinde daha güvenilir sonuçlar elde edilmektedir. ANFIS yaklaşımı, geleneksel bir bulanık çıkarım sisteminin temel unsurlarını, fonksiyonlarını, üyelik fonksiyonları ve bulanık mantık kurallarını elde etmek için öğrenme yeteneğini dağıtan sinir ağı bağlantı yapısı ile birleştirmektedir [9].

V. SONUÇ

Yapay zekâ, gıda endüstrisindeki basitlik, doğruluk ve maliyet tasarrufu sağlama yeteneği sayesinde tanınmaktadır. Modelleme, tahmin, kontrol, gıda kurutma, duyuşal değerlendirme, kalite kontrolü ve karmaşık problemlerin çözümü gibi çeşitli amaçlar için önemli bir araçtır. Yapay zekâ ayrıca tarım faaliyetlerinin verimliliğini arttırmaya yönelik etkili çözümler sunarak sürdürülebilirliğe de katkı sağlamaktadır. Yapay zekanın gıda teknolojisindeki önemi kavrandıkça araştırmacılar daha iyi sonuçlar sağladığı kanıtlanmış olan bu teknolojiyi kullanmaya yönelik çalışmalarını sürdürecektir.

KAYNAKLAR

1. Rockström, J.; Williams, J.; Daily, G.; Noble, A.; Matthews, N.; Gordon, L.; Wetterstrand, H.; DeClerck, F.; Shah, M.; Steduto, P.; et al. Sustainable Intensification of Agriculture for Human Prosperity and Global Sustainability. *Ambio* **2017**, *46*, 4–17, doi:10.1007/s13280-016-0793-6.
2. Godfray, H.C.J.; Beddington, J.R.; Crute, I.R.; Haddad, L.; Lawrence, D.; Muir, J.F.; Pretty, J.; Robinson, S.; Thomas, S.M.; Toulmin, C. Food Security: The Challenge of Feeding 9 Billion People. *Science* **2010**, *327*, 812–818, doi:10.1126/SCIENCE.1185383.
3. Sahni, V.; Srivastava, S.; Khan, R. Modelling Techniques to Improve the Quality of Food Using Artificial Intelligence. *J. Food Qual.* **2021**, *2021*, doi:10.1155/2021/2140010.
4. Önder, M. Yapay Zekâ: Kavramsal Çerçeve. *Yapay Zekâ Strat. ve Türkiye* **2020**, 3–10.
5. Gharaei, A.; Karimi, M.; Hoseini Shekarabi, S.A. An Integrated Multi-Product, Multi-Buyer Supply Chain under Penalty, Green, and Quality Control Policies and a Vendor Managed Inventory with Consignment Stock Agreement: The Outer Approximation with Equality Relaxation and Augmented Penalty Algorithm. *Appl. Math. Model.* **2019**, *69*, 223–254, doi:10.1016/J.APM.2018.11.035.
6. Elavarasan, D.; Vincent, D.R.; Sharma, V.; Zomaya, A.Y.; Srinivasan, K. Forecasting Yield by Integrating Agrarian Factors and Machine Learning Models: A Survey. *Comput. Electron. Agric.* **2018**, *155*, 257–282, doi:10.1016/j.compag.2018.10.024.
7. Zhang, C.; Liu, J.; Shang, J.; Cai, H. Capability of Crop Water Content for Revealing Variability of Winter Wheat Grain Yield and Soil Moisture under Limited Irrigation. *Sci. Total Environ.* **2018**, *631–632*, 677–687, doi:10.1016/J.SCITOTENV.2018.03.004.
8. Mavani, N.R.; Ali, J.M.; Othman, S.; Hussain, M.A.; Hashim, H.; Rahman, N.A. Application of Artificial Intelligence in Food Industry—a Guideline. *Food Eng. Rev.* **2022**, *14*, 134–175, doi:10.1007/s12393-021-09290-z.
9. Rahman, M.S.; Rashid, M.M.; Hussain, M.A. Thermal Conductivity Prediction of Foods by Neural Network and Fuzzy (ANFIS) Modeling Techniques. *Food Bioprod. Process.* **2012**, *90*, 333–340, doi:10.1016/J.FBP.2011.07.001.
10. Rahman, N.A.; Hussain, M.A.; Jahim, M.J. Production of Fructose Using Recycle Fixed-Bed Reactor and Batch Bioreactor. *J. Food, Agric. Environ.* **2012**, *10*, 268–273.
11. Mozafari, M.R.; Khosravi-Darani, K.; Borazan, G.G.; Cui, J.; Pardakhty, A.; Yurdugul, S. Encapsulation of Food Ingredients Using Nanoliposome Technology. *Int. J. Food Prop.* **2008**, *11*, 833–844,

doi:10.1080/10942910701648115.

12. Jayasooriya, S.D.; Bhandari, B.R.; Torley, P.; D'Arcy, B.R. Effect of High Power Ultrasound Waves on Properties of Meat: A Review. *Int. J. Food Prop.* **2004**, *7*, 301–319, doi:10.1081/JFP-120030039.
13. Saha, D.; Bhattacharya, S. Hydrocolloids as Thickening and Gelling Agents in Food: A Critical Review. *J. Food Sci. Technol.* **2010**, *47*, 587–597, doi:10.1007/S13197-010-0162-6/TABLES/3.
14. Belluco, S.; Losasso, C.; Maggioletti, M.; Alonzi, C.C.; Paoletti, M.G.; Ricci, A. Edible Insects in a Food Safety and Nutritional Perspective: A Critical Review. *Compr. Rev. Food Sci. Food Saf.* **2013**, *12*, 296–313, doi:10.1111/1541-4337.12014.
15. Szturo, K.; Szczypinski, P.M. Ontology Based Expert System for Barley Grain Classification. *Signal Process. - Algorithms, Archit. Arrange. Appl. Conf. Proceedings, SPA* **2017**, 2017-September, 360–364, doi:10.23919/SPA.2017.8166893.
16. Zadeh, L.A. Fuzzy Logic—a Personal Perspective. *Fuzzy Sets Syst.* **2015**, *281*, 4–20, doi:10.1016/J.FSS.2015.05.009.
17. Muhammad, L.J.; Algehyne, E.A. Fuzzy Based Expert System for Diagnosis of Coronary Artery Disease in Nigeria. *Health Technol. (Berl)*. **2021**, *11*, 329, doi:10.1007/S12553-021-00531-Z.
18. Hannan, M.A.; Ghani, Z.A.; Hoque, M.M.; Ker, P.J.; Hussain, A.; Mohamed, A. Fuzzy Logic Inverter Controller in Photovoltaic Applications: Issues and Recommendations. *IEEE Access* **2019**, *7*, 24934–24955, doi:10.1109/ACCESS.2019.2899610.
19. Haçat, G.; Çetinçeviz, Y. Neutrosophic Valued PID Controller for Closed Loop V/f Speed Control of Permanent Magnet Synchronous Motor. *Ömer Halisdemir Üniversitesi Mühendislik Bilim. Derg.* **2023**, *12*, 716–725, doi:10.28948/ngumuh.1258587.
20. Kumar, K. Intrusion Detection Using Soft Computing Techniques. *Int. J. Comput. Sci. Commun. Networks* **2016**, *6*, 153–169.
21. Mohd Ali, J.; Hussain, M.A.; Tade, M.O.; Zhang, J. Artificial Intelligence Techniques Applied as Estimator in Chemical Process Systems – A Literature Survey. *Expert Syst. Appl.* **2015**, *42*, 5915–5931, doi:10.1016/J.ESWA.2015.03.023.
22. Angiulli, G.; Versaci, M. A Neuro-Fuzzy Network for the Design of Circular and Triangular Equilateral Microstrip Antennas. *Int. J. Infrared Millimeter Waves* **2002**, *23*, 1513–1520, doi:10.1023/A:1020333704205/METRICS.



Engelli Bireyler İçin Yapay Zeka Tabanlı Ulaşım Sistemlerinin Önündeki Engel Yaratan Faktörlerin Belirlenmesi

Ceyda Al^{1*}, Ertuğrul Ayyıldız²

¹Endüstri Mühendisliği / Fen Bilimleri Enstitüsü, Karadeniz Teknik Üniversitesi, Türkiye

²Endüstri Mühendisliği / Fen Bilimleri Enstitüsü, Karadeniz Teknik Üniversitesi, Türkiye

*(ceydaal@ktu.edu.tr)

Özet – Sürekli gelişen günümüz teknolojisi ile yapay zeka gündelik yaşantımızda birçok alanda bize hizmet etmektedir. Bu alanlardan biri de ulaşım sistemleridir. Genel anlamda yapay zeka, insan hayatını kolaylaştırmak için kullanılıyor olsa bile çeşitli zorlukları da beraberinde getirir. Yapay zeka tabanlı ulaşım sistemleri sağlıklı bireyler için bile zaman zaman anlaşılması/kullanılması güç olmaktadır. Bu durum engelli bireyler için düşünüldüğünde ise zorluklar daha da artmaktadır. Engelli bireylerin ulaşım sistemlerine erişiminde ya da kullanımda karşılaştıkları zorluklar belirli sınıflar altında toplanıp derecelendirilebilir. Bu sayede hangi faktörlerin hangi seviyelerde engel oluşturduğu tespit edilir ve bu engellerin aşılması için hem teknoloji geliştiricileri hem de toplumun diğer paydaşları arasında çeşitli iş birlikleri ve koordinasyon sağlanabilir. Yapay zeka tabanlı ulaşım sistemlerinin engelli bireyler içinde kullanımının kolay ve etkili olabilmesi adına tasarım aşamasından uygulamaya kadar tüm süreçlerde ‘engelli bireyler’ odaklı bir yaklaşım benimsenmelidir. Bu yaklaşımın beraberinde toplumsal farkındalıkta arttırılmalıdır.

Anahtar Kelimeler – Yapay Zeka, Ulaşım, Engelli Bireyler, Faktör Belirleme, Yapay Zeka Destekli Sistemler

I. GİRİŞ

Engellilik toplumun büyük bir kesimi için insan deneyiminin ayrılmaz bir parçasıdır. Günümüzde yaklaşık olarak 1,3 milyar insan (küresel nüfusun %16'sı) önemli bir engellilik yaşamaktadır [1]. Bu bireylerin sahip olduğu engeller günlük yaşantılarında aşılması gereken birçok zorluğu beraberinde getirir. Günlük yaşamın içindeki engeller, ulaşım ile ilgili zorlukları da içererek çeşitli engel türlerini kapsar [2]. Bu bağlamda, ulaşım ve hareketlilik, söz konusu bireylere fırsat eşitliği sağlama konusunda önemli bir rol oynamaktadır [3]. Gelişen teknolojinin ulaşım sistemlerine entegre edilmesi birtakım zorlukların ortadan kaldırılmasını amaçlarken beraberinde farklı güçlüklerde ortaya çıkarmıştır.

Dijital teknoloji (DT), seyahatin planlamasından başlayarak yolculuğun ücretinin ödenmesine kadar her süreci içine alan bir seyahat deneyimine tam anlamıyla entegre edilmiştir. [4].

İnsan-makine etkileşiminin önündeki güçlüklerin tespiti ve bu sorunlara karşı çözüm arayışı oldukça önemlidir.

Yapay zeka tabanlı ulaşım sistemleri gün geçtikçe gelişmektedir. Yapay zekanın ulaşımında kullanımı şu şekilde örneklendirilebilir; otonom araçlar, trafik yönetimi, yol güvenliği, lojistik ve rota optimizasyonu. Bu teknolojilerin kullanımı, ulaşım sektöründe daha güvenli ve sürdürülebilir çözümler geliştirmek amacıyla hızla yayılmaktadır. Tüm bunların yanında son dönemlerde literatürde engellileri de kapsayan ulaşım sistemlerini tasarlamının yeni yollarını arayan çalışmalar yer almaktadır [5].

Bu sistemlerin tasarım aşamasından kullanımına kadar engelli bireyler odaklı düşünülmeli ve buna göre çalışmalar yapılmalıdır. Fakat öncesinde engelli bireyler için güçlük yaratan tüm faktörler belirlenmeli ve ortak çatılar altında toplanmalıdır.

Son teoriler, ulaşımın önündeki temel engelleri tanımlayarak toplu taşıma operatörlerinin karşılaştığı zorluklar hakkında önemli bilgiler sunmuştur [6].

Bu engellerin aşılabilmesi için, sadece teknoloji geliştiricileri değil, aynı zamanda kamu kurumları, sivil toplum örgütleri ve endüstri liderleri arasında güçlü bir iş birliği ve koordinasyon gerekmektedir. Engelli bireylerin ihtiyaçlarına duyarlı tasarımlar, yapay zeka tabanlı ulaşım sistemlerinin başarılı bir şekilde hayata geçirilebilmesi için temel bir adımdır.

Örneğin Mogaji ve Nguyen çalışmalarında ifade etmişlerdir ki; Bazı bireyler, engellilik durumları ve seyahat ihtiyaçlarına destek olacak altyapının eksikliği nedeniyle seyahat faaliyetlerine katılmaktan kaçınmayı tercih edebilirler. Bu durum, dünyanın birçok bölgesinde, çoğu zaman kontrol dışı faktörlerin etkisi altında kalan ve öznel refahlarını olumsuz etkileyen engelli bireylerin karşılaştığı bir dizi zor durumu vurgulamaktadır [7]. Sonuç olarak, yapay zeka tabanlı ulaşım sistemlerinin engelli bireyler tarafından etkili bir şekilde kullanılabilmesi için hem teknik hem de sosyal faktörlerin dikkate alınması kritik bir öneme sahiptir.

II. BELİRLENEN FAKTÖRLER

Günümüzde kullanılan ulaşım sistemlerinin toplumdaki her birey için farklı zorlukları olabilmektedir. Özellikle yapay zeka ile entegre edilmiş sistemlerde farklı güçlükler ortaya çıkmaktadır. Bu güçlüklerin en başında öğrenme gelebilir. Bireylerin yeni sistemlere uyum sağlayabilmesi, öğrenmesi zaman almaktadır. Fakat sağlıklı bireyler için düşünüldüğünde bu durum daha kolaydır. Çünkü toplum içerisinde kendilerine yol gösterecek çok fazla örnekle karşılaşmaktadırlar. Bu eşitliğin engelli bireyler içinde sağlanması gerekmektedir. Sadece 'öğrenme' ile sınırlı kalmayan bu engeller farklı sınıflar altında gruplandırılabilir. Ulaşım sistemlerindeki zorluklar ekonomik, çevresel veya sosyal gibi farklı karakterdeki çatılar altında toplanabilir [8].

Bu çalışmada engel yaratan faktörler, literatür taramasına dayalı olarak ilk etapta dörde ayrılmıştır; (A) Yetersiz eğitim ve sınırlı farkındalık, (B) Ekonomik Engeller, (C) Sosyal Engeller ve (D) Çevresel Engeller.

Yetersiz eğitim ve sınırlı farkındalık kullanıcıların yapay zeka tabanlı sistemleri öğrenmeye çalışırken yaşadığı zorlukları ifade etmektedir. Bu zorluklar insan/makine etkileşimi tabanında düşünüldüğünde cihazların nasıl kullanılacağını bilmemekten başlayarak kullanım esnasında yaşanan güçlükler kadar uzanmaktadır. Kullanıcı dostu olmayan ara yüzler, bireylerin cihazları kullanımını zorlaştırmaktadır. Bunun yanında farklı engellere sahip her birey için uyarlanmış bilgilerin sağlanması gerekmektedir. Örneğin; görme engelli bir birey için dönütlerin sesli şekilde, tam tersi düşünüldüğünde de duyma engelli bir birey için geri bildirimlerin görsel şekilde kişiye iletilmesi gerekmektedir. Özetle; birden fazla etkileşim modu (ses komutları, dokunma, jest tanıma) sunmak, çeşitli engellere sahip bireyleri hedeflemek için önemlidir.

İkinci karakterdeki sorunlar ise maliyetlerle ilgilidir. Ekonomik engeller hayatımızın her alanında karşımıza çıktığı gibi bu konu bazında da önemlidir. Yapay zekanın ulaşım sistemlerine entegre edilmesinin teknolojik maliyeti, çoklu etkileşimin sağlanabilmesinin maliyeti, yetersiz fon desteği ve tüm bunların kullanıcıya olan maliyeti gibi çeşitli zorluklar mevcuttur. Engelli bireylerin karşılaştığı mali zorlukların uygun maliyetli çözümlerin sağlanması önemlidir.

Son olarak ise sosyal engeller ve çevresel engeller birçok farklı alt başlık içermektedir. Özetleyecek olursak; zorlu iklim koşulları engelli bireylerin ulaşım araçlarını kullanmasını önemli ölçüde kısıtlamaktadır. Bunun yanında, olumsuz hava koşullarında kullanılan sensörlerin güvenilirliği azalmaktadır. Taşıma hizmetlerinin bireylere olan uzaklığı güçlük yaratmaktadır. Coğrafi olarak düşünüldüğünde ise çok farklı yerlerde ikamet eden engelli bireyler vardır. Bu kişilerin ulaşım araçlarına erişimiyle ilgili ciddi eşitsizlikler mevcuttur.

<p>(A) Yetersiz eğitim ve sınırlı farkındalık</p>	<ul style="list-style-type: none"> • Kullanıcı dostu olmayan ara yüzler (A1) • Uyarlanmış bilgi sağlanması (A2) • Çoklu Etkileşim Eksikliği (A3)
<p>(B) Ekonomik Engeller</p>	<ul style="list-style-type: none"> • Teknolojinin maliyeti (B1) • Yetersiz fon (destekler) (B2) • Kullanıcı maliyeti (B3)
<p>(C) Sosyal Engeller</p>	<ul style="list-style-type: none"> • Kentsel ve Kırsal Eşitsizlikler (C1) • Emniyet (C2) • Ulaşım personeli ile etkileşim (C3) • Acil Durum Protokolleri (C4)
<p>(D) Çevresel Engeller</p>	<ul style="list-style-type: none"> • Olumsuz iklim koşulları (D1) • Zorlu Hava Koşullarında Sensor Güvenilirliği (D2) • Taşıma hizmetinin kullanılabilirliği/yakınlığı (D3)

Engelli bireylerin ulaşımda yaşadığı en büyük güçlüklerden biri de emniyet sorunudur. Yapay zeka destekli sistemlerde çoğunlukla direkt olarak bir kişi ile iletişim kurulamadığından bireyler güçlük çekebilmektedirler. Ulaşım personelinin engelli bireylerle etkileşiminde daha anlayışlı olabilmesi ve destek sağlaması için eğitim programları düzenlenebilir.

Son olarak ise yapay zeka tabanlı ulaşım sistemleri, acil durumların ele alındığı sağlam protokollere sahip olmalıdır, tüm yolcuların güvenliğini, özellikle de engelli bireylerin güvenliğini sağlanmalıdır. Bunun için özel protokoller oluşturulması gerekmektedir.

III. SONUÇLAR

Sonuç olarak, yapay zeka tabanlı ulaşım sistemlerinin engelli bireyler için gerçekten kullanılabilir ve etkili olabilmesi adına hem teknolojiye duyarlı tasarımlar yapılmalı hem de toplumsal düzeyde farkındalık oluşturulmalı ve eğitim çalışmaları yapılmalıdır. Bu şekilde, teknoloji herkes için daha erişilebilir hale gelerek

toplumun her kesiminden katılım arttırabilir ve yaşam kalitesi iyileştirebilir.

Bu bağlamda zorluk yaratan faktörlerin belirlenmesi, belirlenen faktörlerin önem düzeyine göre sıralanması ve bunlar üzerinden çalışmalar yapılması oldukça önemlidir.

Engelli bireylerin yaşam kalitesini arttırmak için, engelli dostu altyapıların kurulması, güvenlik ve gizlilik standartlarının özenle uygulanması, eğitim ve farkındalık çalışmalarının artırılması gibi adımlar, bu teknolojilerin etkili bir şekilde kullanılmasına olanak sağlayacaktır.

KAYNAKLAR

- [1] World Health Organization. Available online: <https://www.who.int/news-room/fact-sheets/detail/disability-and-health> (accessed on 3 December 2023).
- [2] V. Stjernborg, "Accessibility for all in public transport and the overlooked (social) dimension-A case study of Stockholm," *Sustainability (Switzerland)*, vol. 11, no. 18, 2019, doi: 10.3390/su11184902
- [3] I. M. Hezam, A. R. Mishra, P. Rani, and A. Alshamrani, "Assessing the barriers of digitally sustainable transportation system for persons with disabilities using Fermatean fuzzy double normalization-based multiple aggregation method," *Appl Soft Comput*, vol. 133, 2023, doi: 10.1016/j.asoc.2022.109910.
- [4] M. Manzoor and V. Vimarlund, "Digital technologies for social inclusion of individuals with disabilities," *Health and Technology*, vol. 8, no. 5. 2018. doi: 10.1007/s12553-018-0239-1.
- [5] N. N. Sze and K. M. Christensen, "Access to urban transportation system for individuals with disabilities," *IATSS Research*, vol. 41, no. 2. 2017. doi: 10.1016/j.iatssr.2017.05.002.
- [6] J. L. Bezyak, S. A. Sabella, and R. H. Gattis, "Public Transportation: An Investigation of Barriers for People With Disabilities," *J Disabil Policy Stud*, vol. 28, no. 1, 2017, doi: 10.1177/1044207317702070.
- [7] E. Mogaji and N. P. Nguyen, "Transportation satisfaction of disabled passengers: Evidence from a developing country," *Transp Res D Transp Environ*, vol. 98, 2021, doi: 10.1016/j.trd.2021.102982.
- [8] Givoni, M.; Macmillen, J.; Banister, D.; Feitelson, E. From Policy Measures to Policy Packages. *Transp. Rev.* 2013, 33, 1–20. [CrossRef]
- [9] G. W. Bascom and K. M. Christensen, "The impacts of limited transportation access on persons with disabilities' social participation," *J Transp Health*, vol. 7, 2017, doi: 10.1016/j.jth.2017.10.002.
- [10] A. Neven, K. Braekers, K. Declercq, G. Wets, D. Janssens, and T. Bellemans, "Assessing the impact of different policy decisions on the resource requirements of a Demand Responsive Transport system for persons with disabilities," *Transp Policy (Oxf)*, vol. 44, 2015, doi: 10.1016/j.tranpol.2015.06.011.
- [11] M. Cerdan Chiscano, "Improving the design of urban transport experience with people with disabilities," *Research in Transportation Business and Management*, vol. 41, 2021, doi: 10.1016/j.rtbm.2020.100596.
- [12] V. Stjernborg and O. Mattisson, "The role of public transport in society-A case study of general policy documents in Sweden," *Sustainability (Switzerland)*, vol. 8, no. 11, 2016, doi: 10.3390/su8111120.
- [13] J. Schlingensiepen, E. Naroska, T. Bolten, O. Christen, S. Schmitz, and C. Ressel, "Empowering People with Disabilities Using Urban Public Transport," *Procedia Manuf*, vol. 3, 2015, doi: 10.1016/j.promfg.2015.07.382.



Karaciğer Fibrozisi Evrelerinin Tahmininde Makine Öğrenimi Tabanlı Web Arayüzü

Hakan Yılmaz^{1*}, Hatice Şevval Baki¹, Zeynep Nida Can¹, Tahsin Çökmez¹, Mehmet Özdem²

¹Tıp Mühendisliği Bölümü / Mühendislik Fakültesi, Karabük Üniversitesi, Türkiye

²Türk Telekom, Türkiye

**(hakanyilmaz@karabuk.edu.tr) Başlıca yazarın mail adresi*

Özet – Karaciğer fibrozu, çeşitli faktörlerin neden olduğu kronik karaciğer hasarının yaygın bir sonucudur. Hepatit virüsleri, alkol tüketimi, karaciğer yağlanması ve otoimmün hastalıklar gibi etkenler, karaciğer fibrozisinin gelişiminde rol oynayabilir. Bu nedenle, fibrozisin altında yatan nedenlerin anlaşılması, tanı ve tedavi için hayati öneme sahiptir. Erken teşhis, karaciğer fibrozisinin siroz, hepatoselüler karsinom ve diğer komplikasyonlara ilerlemesini engelleyebilir.

Geleneksel olarak, karaciğer biyopsisi fibrozisin teşhisi için altın standart olarak kabul edilir. Ancak, bu yöntem invaziv olması ve örnek alma sırasında ortaya çıkabilecek değişkenlikler gibi sınırlamaları vardır. Bu nedenle, invazif olmayan yöntemlerin kullanımı, karaciğer fibrozisinin tanısı için umut vaat etmektedir.

Makine öğrenimi, karaciğer fibrozisinin tahmin edilmesi ve değerlendirilmesinde etkili bir araç haline gelmiştir. Çeşitli çalışmalar, makine öğrenimi algoritmalarının karaciğer fibrozisi evrelerini doğru bir şekilde belirlemede başarılı olduğunu göstermektedir. Bu çalışmada, Nasr ve diğerleri tarafından oluşturulan ve UCI Makine Öğrenmesi Arşivi'nde bulunan bir veri seti kullanılmıştır. Çalışmada çok katmanlı algılayıcı (MLP) kullanılarak model oluşturulmuş ve 5 katlı çapraz doğrulama ile doğruluk değeri %98,88 olarak hesaplanmıştır.

Sonuçlar, modelin karaciğer fibrozisinin tanı ve evrelemesi için etkili bir araç olduğunu göstermektedir. Ayrıca, oluşturulan web arayüzü sayesinde bireylerin kendi bilgilerini ve kan tahlili sonuçlarını kullanarak karaciğer fibrozisi evrelerini tahmin edebilecekleri bir ortam sağlanmıştır. Gelecekte, farklı algoritmaların denenmesi ve bölgesel veri setlerinin oluşturulmasıyla ilgili çalışmalar yapılabilir.

Anahtar Kelimeler – Karaciğer Fibrozu, Makine Öğrenimi, Çok Katmanlı Algılayıcı (MLP), Karaciğer Fibroz Evreleri, Sınıflandırma

I. GİRİŞ

Karaciğer fibrozu, hepatit virüsleri, alkol tüketimi, karaciğer yağlanması ve otoimmün hastalıkları gibi çeşitli faktörlerin neden olduğu kronik karaciğer hasarına verilen yaygın bir isimdir [1]. Hipoksinin rolü de dahil olmak üzere karaciğer fibrozunun altında yatan nedenleri anlamak, tanı ve tedavi için çok önemlidir [2]. Karaciğer fibrozisinin siroz, hepatoselüler karsinom ve diğer komplikasyonlara ilerleyemeden durdurulması erken tanının önemini vurgulamaktadır [3]. Karaciğer biyopsisi geleneksel olarak fibrozisin teşhisinde altın standart olsa da invaziv bir yöntem olması ve örnekleme sırasında ortaya çıkabilecek değişkenlikler gibi sınırlamaları vardır [4]. Manyetik rezonans görüntüleme ve elastografi gibi invazif olmayan yöntemler, karaciğer fibrozisinin tanısında umut vaat etmektedir [5]. Ayrıca, karaciğer fibrozunun doğru ve erken tespiti için derin öğrenme ve iki fotonlu floresan görüntüleme gibi teknolojilerdeki çalışmalar her geçen gün artmaktadır [6], [7].

Makine öğrenmesi, karaciğer fibrozunu tahmin etme ve değerlendirmede güçlü bir araç haline gelmiştir. Çeşitli çalışmalar bu alanda makine öğrenmesi algoritmalarının etkinliğini göstermiştir. Örneğin, Sharma ve diğerleri karaciğer fibrozisini doğru bir şekilde tespit etmek ve sınıflandırmak için yakın kızılötesi

spektroskopi ve makine öğrenmesinden yararlanmıştır [8]. Benzer şekilde Yu ve diğerleri, özellikle hepatit B ve C hastalarında karaciğer fibrozis aşamalarının tahmin edilmesinde makine öğrenmesinin popülerliğine dikkat çekmiştir [9]. Ayrıca Decharatanachart ve diğerleri, karaciğer fibrozunun değerlendirilmesi ve nakil sonrası sonuçların tahmin edilmesi de dahil olmak üzere, hepatolojide makine öğrenmesinin çeşitli uygulamalarını vurgulayan sistematik bir inceleme gerçekleştirmiştir [10]. Sartakhti ve diğerleri, çalışmalarında hepatit hastalığının teşhisi için destek vektör makinası tabanlı yeni bir hibrit yöntem kullanmışlardır ve kullandıkları yöntemin hepatit hastalık verilerini sınıflandırmada yüksek başarı gösterdiğini belirtmişlerdir [11]. Karthikeyan ve Thangaraju yaptıkları çalışmada karaciğer hastalarına ait verileri kullanarak farklı sınıflandırma algoritmalarını karşılaştırmışlardır [12]. Sachdeva ve diğerleri ise hepatit hastalığı tanısına yönelik sistematik bir strateji geliştirmek amacıyla UCI veri kümesinde farklı sınıflandırıcıların performansını değerlendirmişlerdir [13]

Makine öğrenmesi modelleri, karaciğer fibrozis aşamalarının belirlenmesinde geleneksel yöntemlere göre üstünlük göstermiştir. Chang ve diğerleri derin öğrenme modellerini kullanarak farklı fibrozis aşamalarını tahmin etmede yüksek tanılabilirlik elde etmişlerdir [14]. Ayrıca Wu ve diğerleri, makine öğrenmesi yöntemlerini, alkolsüz steatohepatit ve ilerlemiş karaciğer fibrozisinin teşhisine yönelik mevcut risk puanlarıyla karşılaştırmış ve makine öğrenmesinin teşhis doğruluğunu artırmadaki potansiyelini ortaya koymuştur [15]. Makine öğrenmesi pediatrik hepatolojide de uygulanmıştır ve hepatit C virüsü olan çocuklarda hepatik fibrozisin öngörülmesi ve evrelendirilmesinde değerli olduğu kanıtlanmıştır [16]. Hepatik ve splenik BT taramalarından elde edilen radyomik özelliklerin birleştirilmesi, karaciğer fibrozisi evrelemesi için radyomik analizin performansını da arttırmıştır [17].

Sonuç olarak, makine öğrenimi algoritmalarının karaciğer fibrozisini öngörmede entegrasyonu, karaciğer fibrozisinin teşhisi ve evrelemesi için doğru, invazif olmayan ve etkili yöntemler sağlayarak alanda öne çıkmaktadır. Bu ilerlemeler, hasta sonuçlarının iyileştirilmesi ve karaciğer hastalığı yönetiminde tedavi stratejilerinin optimize edilmesi konusunda ümit vericidir. Bu çalışmada karaciğer fibrozisinin evrelerini tahmin etmeyi amaçlayan makine öğrenmesi temelli bir web arayüzü oluşturulması amaçlanmıştır. Bireyin kendi bilgilerini ve kan tahlili sonuçlarını girdikten sonra karaciğer fibrozisinin durumunun tahmin edilmesi hedeflenmektedir.

II. MATERYAL VE YÖNTEM

A. Kullanılan Veri Seti

Karaciğer fibrozunun evrelerini tahmin etmek için Nasr ve arkadaşları tarafından oluşturulan ve UCI Makine Öğrenmesi Arşivi üzerinden ulaşılabilen, halka açık bir veri seti kullanılmıştır [18]. Bu veri setinde 1385 adet kayıt bulunmaktadır. Bu kayıtlar, yaş cinsiyet, vücut kütle indeksi, baş ağrısı, kusma, yorgunluk gibi kişinin kendi cevaplayacağı verilerle birlikte kan tahlili sonucu elde edilebilecek beyaz kan hücreleri sayısı, kırmızı kan hücreleri sayısı, hemoglobin gibi değerleri içermektedir. Bu verilerin sonucunda ise bireyin karaciğer fibrozuna ait evre bulunmaktadır. İlgili veri setinde karaciğer fibrozis durumları “portal fibrozis (septa olmadan)”, “az sayıda septa”, “birçok septa (siroz olmadan)” ve “siroz” olarak ilişkilendirilmiştir. Bu sınıflara ait örnek sayıları ise sırasıyla 336, 332, 355 ve 362'dir. Çalışma sonunda elde edilen web arayüzüne kişilerin laboratuvarında yaptıkları kan tahliline ait sonuçları kolayca girip tahmini sonuç almaları amaçlanmıştır. Bu yüzden standart kan tahlili sonucunda görüntülemeyebilen “RNA” ile ilgili sütunlar veri setinden çıkarılmıştır. Çalışma kapsamında kullanılan veri setine ait özet bilgiler Tablo 1’de verilmiştir.

B. Kullanılan Programlama Ortamı

Veri setinin işlenmesi, ön hazırlık işlemlerinin yapılması, yapay sinir ağı modelinin kurulması ve ağırlıkların elde edilmesi işleri Intel i7 işlemcili, 16 GB belleğe sahip bir bilgisayarda ve Python programlama dili kullanılarak yapılmıştır. Web sayfasının tasarımı için ise html, css ve JavaScript dilleri kullanılmıştır.

Tablo 1. Kullanılan veri setine ait özet bilgi.

Özellik	Veri aralığı	Açıklama	Veri tipi
Yaş	32-61	Hastaların yaş bilgisi	Sayısal
Cinsiyet	1-2	1: Erkek, 2: Kadın	Kategorik
BMI	22-35	Hastalara ait vücut kütle indeksi	Sayısal
Ateş	1-2	1: Ateşi normal, 2: Ateşi yüksek	Kategorik
Mide bulantısı/Kusma	1-2	1: Yok, 2: Var	Kategorik
Baş ağrısı	1-2	1: Yok, 2: Var	Kategorik
İshal	1-2	1: Yok, 2: Var	Kategorik
Yorgunluk ve genel kemik ağrısı	1-2	1: Yok, 2: Var	Kategorik
Sarılık	1-2	1: Yok, 2: Var	Kategorik
Epigastrik ağrı	1-2	1: Yok, 2: Var	Kategorik
WBC	2991–12101	Beyaz kan hücre sayısı	Sayısal
RBC	3816422–5018451	Kırmızı kan hücre sayısı	Sayısal
HGB	10:15	Hemoglobin seviyesi	Sayısal
PLT	93013:226464	Trombosit sayısı	Sayısal
AST 1	39-128	1 haftalık aspartat transaminaz oranı	Sayısal
ALT 1	39-128	1 haftalık alanin transaminaz oranı	Sayısal
ALT 4	39-128	4 haftalık alanin transaminaz oranı	Sayısal
ALT 12	39-128	12 haftalık alanin transaminaz oranı	Sayısal
ALT 24	39-128	24 haftalık alanin transaminaz oranı	Sayısal
ALT 36	39-128	36 haftalık alanin transaminaz oranı	Sayısal
ALT 48	39-128	48 haftalık alanin transaminaz oranı	Sayısal
Evre	1-4	Karaciğer fibrozis evresi	Kategorik

C. Veri Ön Hazırlık İşlemleri ve Çok Katmanlı Algılayıcı

Veri setinin son halinde 21 tane girdi olarak kullanılacak, 1 tane ise çıktı olarak kullanılacak özellik bulunmaktadır. Girdi özelliklerden 8 tanesi kategorik veridir. Geri kalan 13 tanesi ise sayısal veridir. İlk olarak kategorik veriler düzenlenerek sütunların 0 ve 1'lerden oluşması sağlanmıştır. Daha sonra ise sayısal veriler üzerine min-max normalizasyonu uygulanmıştır. Böylece girdi olarak kullanılacak veriler hazır hale gelmiştir. Çıktı olarak kullanılacak sütuna ise müdahale edilmemiştir.

Çok katmanlı algılayıcı (MLP), yapay sinir ağlarının en temel ve yaygın formlarından biridir. Bu yapı, insan beyninin bilgi işleme şeklini taklit etmeye çalışan matematiksel bir modeldir. MLP, birbirine bağlı nöronlardan (yapay sinir hücrelerinden) oluşan birden fazla katmana sahiptir. MLP sınıflandırıcısı, giriş ve çıkış katmanları arasında yer alan bir veya daha fazla gizli katmana sahip, doğrusal olmayan bir geri yayımlı sinir ağını içerir [19]. Bu gizli katmanlar, MLP'nin veriler içindeki karmaşık kalıpları ve ilişkileri öğrenmesine olanak tanır. MLP, bir algılayıcıya kıyasla birden fazla ara gizli katmana sahip olmasıyla karakterize edilir [20].

Pratik uygulamalarda MLP sınıflandırıcı, görüntü sınıflandırması ve segmentasyonu gibi çeşitli alanlarda yaygın olarak kullanılmaktadır. Bir MLP'nin eğitimi, verilerden çıkarılan özelliklerin kullanımını içerir ve bunlar daha sonra öğrenme ve karar verme için sınıflandırıcıyı beslemektedir. MLP, öğrenme süreci sırasında ağırlıklarını ve biaslarını ayarlamak için geri yayılım gibi algoritmalar kullanılarak eğitilebilir [19], [21].

MLP sınıflandırıcı, gizli katmanlar aracılığıyla karmaşık kalıpları öğrenme yeteneğiyle bilinen, makine öğrenimi ve yapay zeka alanında güçlü bir araçtır. Birden fazla gizli katman içeren yapısı, farklı alanlardaki çeşitli sınıflandırma görevlerinde başarılı olmasına olanak tanır ve bu da onu birçok uygulama için çok yönlü ve etkili bir seçim haline getirir. Bu çalışma kapsamında tahmin modelinin oluşturulması için bir MLP sınıflandırıcı kullanılmıştır. Kullanılan sınıflandırıcı, giriş katmanı, 3 tane gizli katman ve çıkış katmanı olmak üzere toplam 5 katmanlıdır. Gizli katmanlar sırasıyla 8, 16 ve 8 nörona sahiptir. İterasyon sayısı olarak 300, çözümlenici olarak "SGD" yöntemi ve aktivasyon fonksiyonu olarak "relu" tercih edilmiştir.

D. Kullanılan Metrikler ve Çapraz Doğrulama

Çapraz doğrulama, makine öğreniminde model değerlendirmede ve hiper parametre ayarlama da çok önemli bir rol oynayan temel bir tekniktir. Veri kümesini alt kümelerine bölmeyi, modeli verinin bir kısmı üzerinde eğitmeyi ve geri kalan kısımda doğrulamayı içerir. Bu süreç, modelin performansının değerlendirilmesinde sağlamlık ve güvenilirliği sağlamak için birçok kez tekrarlanır [22].

K-katlı (K-fold) çapraz doğrulama ve Monte-Carlo çapraz doğrulama gibi çeşitli çapraz doğrulama yöntemleri, makine öğreniminin farklı alanlarında yaygın olarak kullanılır. Örneğin tıbbi araştırmalarda, bu algoritmaların eğitim verilerini test verileri olarak kullanamaması nedeniyle makine öğrenmesi algoritmalarını değerlendirmek için 5 veya 10 kat çapraz doğrulama sıklıkla kullanılmaktadır [23], [24]. Bu çalışmada da 5 katlı çapraz doğrulama kullanılmıştır.

Sonuçları tartışmak için karışıklık matrisi, doğruluk (accuracy) ve F_1 puanı kullanılmıştır. Karışıklık matrisi, makine öğrenimi, istatistik ve veri analizi gibi çeşitli alanlarda çok önemli bir araçtır. Doğru pozitif (TP), gerçek negatif (TN), yanlış pozitif (FP) ve yanlış negatif (FN) tahminleri sıralayarak bir sınıflandırma modelinin performansının tablo halinde bir özetini sunar. Bu matris doğruluk, kesinlik, geri çağırma ve F_1 puanı gibi ölçümleri değerlendirmek için gereklidir [25]. Doğruluk ve F_1 puanı hesaplamak için kullanılan denklemler Denklem 1 ve Denklem 2' verilmiştir.

$$\text{Doğruluk} = \frac{TP + TN}{TP + TN + FP + FN} \quad (\text{Denklem 1})$$

$$F_1 = \frac{TP}{TP + \frac{1}{2}(FP + FN)} \quad (\text{Denklem 2})$$

Verinin işlenmesi, tahmin modelinin kurulması ve tahmin sürecine ilişkin şema Şekil 1'de verilmiştir.

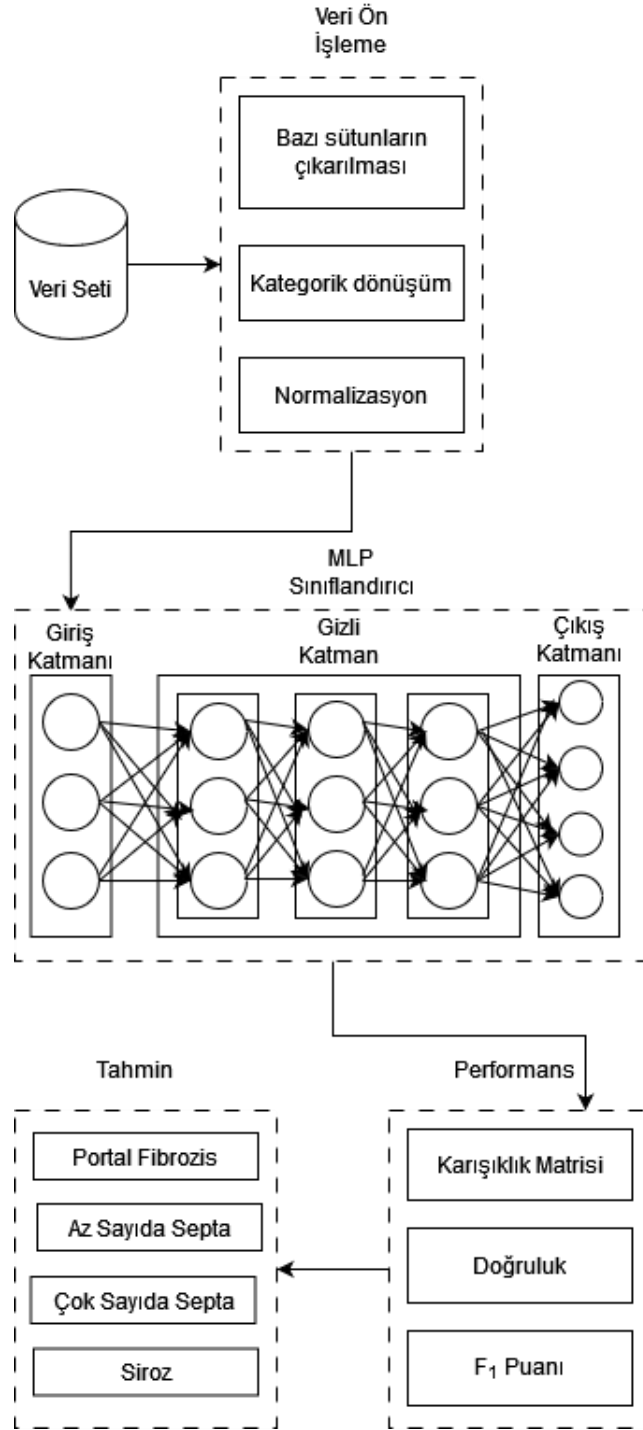

Şekil 1. Tahmin süreci.

III. SONUÇLAR

Kullanılan makine öğrenmesinin sonuçlarını görmek ve performansını değerlendirmek için 5 katlı çapraz doğrulama kullanılmıştır. Veri seti 5 farklı parçaya bölünerek her seferinde 1 parçası test amaçlı, kalanı ise eğitim amaçlı kullanılmıştır. Yapılan çapraz doğrulama sonucunda çıkan sonuç Tablo 2’de verilmiştir.

Tablo 2. Çapraz doğrulama sonuçları.

Çapraz Doğrulama Adımı	Doğruluk (acc) Değeri (%)
1. Doğrulama	98.64
2. Doğrulama	98.92
3. Doğrulama	99.28
4. Doğrulama	99.64
5. Doğrulama	97.92
Ortalama	98.88

Karışıklık matrisine bakıldığında ise genel olarak sınıflandırmanın yüksek başarı elde ettiği görülmektedir. Sınıflara ait doğruluk değerleri Şekil 2’de verilmiştir. F_1 puanı ise her bir sınıf için sırasıyla 0.986, 0.911, 0.975 ve 0.978 olarak bulunmuştur. Genel doğruluk değeri ise %98,88 olarak hesaplanmıştır.

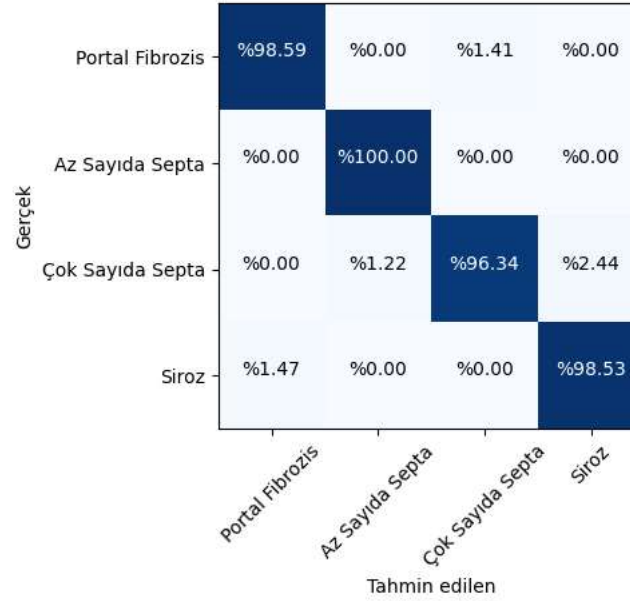

Şekil 2. Karışıklık matrisi.

Kullanıcıların web tabanlı olarak tahmin sorgulamalarını yapabilmeleri için bir web arayüzü tasarlanmıştır. Oluşturulan MLP sınıflandırıcının ağırlıkları kaydedilerek web arayüzü üzerinden erişilmesi sağlanmıştır. Bu web arayüzünde gerekli bilgiler girildikten sonra “Tahmin Et” butonuna basıldığında en yakın sonuç sınıfı ekrana getirilmektedir (Şekil 3).

Medikal Test Sonuç Formu

Cinsiyet	Erkek	HGB	11
Yaş	59	PLT	187684
Boy (m)	1.75	RBC	4606375
Kilo (kg)	86	WBC	3661
Ateş	Yok	AST 1(Aspartat Aminotransferaz Oranı 1.Hafta)	99
Baş Ağrısı	Var	ALT 1(Alanin Aminotransferaz Oranı 1.Hafta)	104
Bulanz & Kusma	Yok	ALT 4(Alanin Aminotransferaz Oranı 4.Hafta)	67
Yorgunluk & Kemik Ağrısı	Var	ALT 24(Alanin Aminotransferaz Oranı 24.Hafta)	48
Karın Ağrısı	Var	ALT 24(Alanin Aminotransferaz Oranı 24.Hafta)	120
Sarılık	Var	ALT 36(Alanin Aminotransferaz Oranı 36.Hafta)	94
İshal	Yok	ALT 48(Alanin Aminotransferaz Oranı 48.Hafta)	90

Tahmin Et

Portal Fibrozis

Şekil 3. Tahmin yapılan web sayfasına ait ara yüz.

IV. TARTIŞMA VE ÖNERİLER

Bu çalışma kapsamında kullanılan veri setini kullanan literatürdeki diğer çalışmalar da incelenerek metrikleri çıkarılmıştır ve Tablo 3'te sunulmuştur. Sonuçlar incelendiğinde önerilen çalışmanın diğer birçok çalışmadan daha iyi doğruluk değerine sahip olduğu görülmüştür.

Tablo 3. Aynı veri setini kullanan çalışmalara ait doğruluk değerleri.

Çalışma	Yöntem	Doğruluk (%)
Ghazal vd. [26]	Gaussian Destek Vektör Makinesi	97.90
Elshewey vd. [27]	Optimize Gradient Boosting	95.30
Alotaibi vd. [28]	Ekstra Ağaç Modeli	96.92
Nasr vd. [29]	Kural Tabanlı Sınıflandırıcı	99.48
Butt vd. [30]	Yapay Sinir Ağı	94.44 (kesinlik)
Nandipati vd. [31]	Rasgele Orman	54.56
Önerilen Çalışma	Çok Katmanlı Algılayıcı	98.88

Bu çalışmada, kişilerin karaciğer fibrozis evrelerini kendi bilgileri ve kan tahlili değerlerini kullanarak kolay sorgulama yapacakları makine öğrenmesi tabanlı bir web arayüz oluşturmak amaçlanmıştır.

Halka açık olan bir veri seti eğitim ve validasyon için kullanılmış olup, modelin oluşturulması için çok katmanlı algılayıcı kullanılmıştır. Elde edilen modelin genelliğini sorgulamak için 5 katlı çapraz doğrulama kullanılmış ve ortalama %98.88 doğruluk değeri elde edilmiştir.

Oluşturulan modele ait ağırlıklar ve bias değerleri kaydedilerek web arayüz üzerinden tahmin yapılması sağlanmıştır.

Literatürde yer alan aynı veri setini kullanan çalışmalar incelenerek elde edilen sonuçlar ile kıyaslanmış ve ilgili çalışmalar arasında yüksek doğruluk oranı elde edildiği görülmüştür.

Sonraki çalışmalarda farklı algoritmalar denenerek çıkan sonuçlar tartışılabilir. Ülkemiz için bir veri seti oluşturularak daha bölgesel bir çalışma gerçekleştirilebilir.

KAYNAKLAR

- [1] E. Seki ve D. A. Brenner, "Recent advancement of molecular mechanisms of liver fibrosis", *J Hepatobiliary Pancreat Sci*, c. 22, sy 7, ss. 512-518, Tem. 2015, doi: 10.1002/jhbp.245.
- [2] J. Cai, M. Hu, Z. Chen, ve Z. Ling, "The roles and mechanisms of hypoxia in liver fibrosis", *J Transl Med*, c. 19, sy 1, s. 186, May. 2021, doi: 10.1186/s12967-021-02854-x.
- [3] G. L. Wong, "Non-invasive assessments for liver fibrosis: The crystal ball we long for", *J of Gastro and Hepatol*, c. 33, sy 5, ss. 1009-1015, May. 2018, doi: 10.1111/jgh.14103.
- [4] L. Petitclerc, G. Gilbert, B. N. Nguyen, ve A. Tang, "Liver Fibrosis Quantification by Magnetic Resonance Imaging", *Topics in Magnetic Resonance Imaging*, c. 26, sy 6, ss. 229-241, Ara. 2017, doi: 10.1097/RMR.000000000000149.
- [5] H. Xiao, M. Shi, Y. Xie, ve X. Chi, "Comparison of diagnostic accuracy of magnetic resonance elastography and Fibroscan for detecting liver fibrosis in chronic hepatitis B patients: A systematic review and meta-analysis", *PLoS ONE*, c. 12, sy 11, s. e0186660, Kas. 2017, doi: 10.1371/journal.pone.0186660.
- [6] N. Fan vd., "Rapid Two-Photon Fluorescence Imaging of Monoamine Oxidase B for Diagnosis of Early-Stage Liver Fibrosis in Mice", *Anal. Chem.*, c. 93, sy 18, ss. 7110-7117, May. 2021, doi: 10.1021/acs.analchem.1c00815.
- [7] Z. Zhu, D. Lv, X. Zhang, S.-H. Wang, ve G. Zhu, "Deep Learning in the Classification of Stage of Liver Fibrosis in Chronic Hepatitis B with Magnetic Resonance ADC Images", *Contrast Media & Molecular Imaging*, c. 2021, ss. 1-9, Ara. 2021, doi: 10.1155/2021/2015780.
- [8] V. J. Sharma vd., "Point-of-care detection of fibrosis in liver transplant surgery using near-infrared spectroscopy and machine learning", *Health Science Reports*, c. 6, sy 11, s. e1652, Kas. 2023, doi: 10.1002/hsr2.1652.
- [9] Y. Yu vd., "Deep learning enables automated scoring of liver fibrosis stages", *Sci Rep*, c. 8, sy 1, s. 16016, Eki. 2018, doi: 10.1038/s41598-018-34300-2.
- [10] P. Decharatanachart, R. Chaiteerakij, T. Tiyyarattanachai, ve S. Treeprasertsuk, "Application of artificial intelligence in non-alcoholic fatty liver disease and liver fibrosis: a systematic review and meta-analysis", *Therap Adv Gastroenterol*, c. 14, s. 175628482110628, Oca. 2021, doi: 10.1177/17562848211062807.
- [11] J. S. Sartakhti, M. H. Zangooci, ve K. Mozafari, "Hepatitis disease diagnosis using a novel hybrid method based on support vector machine and simulated annealing (SVM-SA)", *Computer Methods and Programs in Biomedicine*, c. 108, sy 2, ss. 570-579, Kas. 2012, doi: 10.1016/j.cmpb.2011.08.003.
- [12] T. Karthikeyan ve P. Thangaraju, "Analysis of Classification Algorithms Applied to Hepatitis Patients", *IJCA*, c. 62, sy 15, ss. 25-30, Oca. 2013, doi: 10.5120/10157-5032.
- [13] S. Rk, B. P, R. P, S. V, ve A. R, "A systematic method for diagnosis of hepatitis disease using machine learning", *Innovations in systems and software engineering*, c. 19, sy 1, 2023, doi: 10.1007/s11334-022-00509-8.
- [14] D. Chang vd., "Machine learning models are superior to noninvasive tests in identifying clinically significant stages of NAFLD and NAFLD-related cirrhosis", *Hepatology*, c. 77, sy 2, ss. 546-557, Şub. 2023, doi: 10.1002/hep.32655.
- [15] Y. Wu vd., "Noninvasive Diagnosis of Nonalcoholic Steatohepatitis and Advanced Liver Fibrosis Using Machine Learning Methods: Comparative Study With Existing Quantitative Risk Scores", *JMIR Med Inform*, c. 10, sy 6, s. e36997, Haz. 2022, doi: 10.2196/36997.
- [16] N. H. Barakat, S. H. Barakat, ve N. Ahmed, "Prediction and Staging of Hepatic Fibrosis in Children with Hepatitis C Virus: A Machine Learning Approach", *Healthc Inform Res*, c. 25, sy 3, s. 173, 2019, doi: 10.4258/hir.2019.25.3.173.
- [17] Y. Yin, D. Yakar, R. A. J. O. Dierckx, K. B. Mouridsen, T. C. Kwee, ve R. J. De Haas, "Combining Hepatic and Splenic CT Radiomic Features Improves Radiomic Analysis Performance for Liver Fibrosis Staging", *Diagnostics*, c. 12, sy 2, s. 550, Şub. 2022, doi: 10.3390/diagnostics12020550.
- [18] "HCV data". UCI Machine Learning Repository, 2020. doi: 10.24432/C5D612.
- [19] W. H. A. Wan Zunaidi, R. R. Saedudin, Z. Ali Shah, S. Kasim, C. Sen Seah, ve M. Abdurhman, "Performances Analysis of Heart Disease Dataset using Different Data Mining Classifications", *Int. J. Adv. Sci. Eng. Inf. Technol.*, c. 8, sy 6, ss. 2677-2682, Ara. 2018, doi: 10.18517/ijaseit.8.6.5042.
- [20] K. Wang, "A data fusion-based method for detecting difficult yoga postures", içinde *International Conference on Computer Graphics, Artificial Intelligence, and Data Processing (ICCAID 2022)*, R. Liang ve J. Wang, Ed., Guangzhou, China: SPIE, May. 2023, s. 179. doi: 10.1117/12.2674850.
- [21] M. Maktabdar Oghaz, M. A. Maarof, A. Zainal, M. F. Rohani, ve S. H. Yaghoubyan, "A Hybrid Color Space for Skin Detection Using Genetic Algorithm Heuristic Search and Principal Component Analysis Technique", *PLoS ONE*, c. 10, sy 8, s. e0134828, Ağu. 2015, doi: 10.1371/journal.pone.0134828.
- [22] S. Barratt ve R. Sharma, "Optimizing for Generalization in Machine Learning with Cross-Validation Gradients", 2018, doi: 10.48550/ARXIV.1805.07072.
- [23] J. Li vd., "Machine Learning Prediction Model for Acute Renal Failure After Acute Aortic Syndrome Surgery", *Front. Med.*, c. 8, s. 728521, Oca. 2022, doi: 10.3389/fmed.2021.728521.

- [24] J. Jeon, N. Seo, J.-G. Jung, S. B. Son, ve S.-J. Lee, "Machine Learning Prediction for Cementite Precipitation in Austenite of Low-Alloy Steels", *Mater. Trans.*, c. 63, sy 10, ss. 1369-1374, Eki. 2022, doi: 10.2320/matertrans.MT-MB2022009.
- [25] T. Hall, S. Beecham, D. Bowes, D. Gray, ve S. Counsell, "A Systematic Literature Review on Fault Prediction Performance in Software Engineering", *IEEE Trans. Software Eng.*, c. 38, sy 6, ss. 1276-1304, Kas. 2012, doi: 10.1109/TSE.2011.103.
- [26] T. M. Ghazal vd., "Hep-Pred: Hepatitis C Staging Prediction Using Fine Gaussian SVM", *Computers, Materials & Continua*, c. 69, sy 1, ss. 191-203, 2021, doi: 10.32604/cmc.2021.015436.
- [27] A. M. Elshewey vd., "Optimizing HCV Disease Prediction in Egypt: The hyOPTGB Framework", *Diagnostics*, c. 13, sy 22, s. 3439, Kas. 2023, doi: 10.3390/diagnostics13223439.
- [28] A. Alotaibi vd., "Explainable Ensemble-Based Machine Learning Models for Detecting the Presence of Cirrhosis in Hepatitis C Patients", *Computation*, c. 11, sy 6, s. 104, May. 2023, doi: 10.3390/computation11060104.
- [29] M. Nasr, K. El-Bahnasy, M. Hamdy, ve S. M. Kamal, "A novel model based on non invasive methods for prediction of liver fibrosis", içinde 2017 13th International Computer Engineering Conference (ICENCO), Cairo, Egypt: IEEE, Ara. 2017, ss. 276-281. doi: 10.1109/ICENCO.2017.8289800.
- [30] M. B. Butt vd., "Diagnosing the Stage of Hepatitis C Using Machine Learning", *Journal of Healthcare Engineering*, c. 2021, ss. 1-8, Ara. 2021, doi: 10.1155/2021/8062410.
- [31] S. C. Nandipati, C. XinYing, ve K. K. Wah, "Hepatitis C Virus (HCV) Prediction by Machine Learning Techniques", *Applications of Modelling and Simulation*, c. 4, sy 0, Art. sy 0, Mar. 2020.



Environmental Footprint of Data Centers

Rafika HELAIMIA *

Department of English, University of Mohamed Cherif Messadia, Soukaharas, Algeria

**r.helaimia@univ-soukaharas.dz*

Abstract – In our modern era, the use of cloud computing, internet technology, and related information and communication technologies (ICT) has grown exponentially. As a result, the need for these tools has increased significantly. To meet this demand, data centers have emerged as critical facilities for providing the necessary infrastructure. Data centers allow for the entry, storage, processing, management, and distribution of data worldwide. This has made it possible for businesses, organizations, and individuals to access and share vast amounts of data quickly and efficiently. However, the rapid growth of data centers has two significant drawbacks that need to be addressed. Firstly, data centers have a negative impact on the well-being of people, animals, and the environment. The massive energy, water, and electricity consumption required to power data centers is leading to air pollution, water contamination, and other environmental problems. Unfortunately, this consumption has resulted in an environmental footprint that pollutes the air, increases global warming, diffuses CO₂ emissions, pollutes water, and generates a considerable amount of waste material. This article recognizes the potential negative impact of data centers and takes steps to mitigate their environmental impact. This can include the use of renewable energy sources, increased energy efficiency, and the development of more sustainable data center designs. By doing so, we can continue to enjoy the benefits of data centers while minimizing their environmental footprint.

Keywords – Data Centers, Types, Benefits, Footprint, Green Datacenters

I. INTRODUCTION

In today's digital world, the field of information and communication technologies is evolving rapidly, leading to significant changes in various aspects of our lives. From social interactions to economic transactions, these technologies have become an integral part of our daily routine. As a result, the amount of data traffic has increased exponentially, and data processing and storage have become critical factors in this domain. To cope up with this massive influx of data, we need to have data centers dispersed across the globe.

However, as we continue to focus on expanding the digital infrastructure, we have neglected to consider the environmental impact of data centers. Data centers consume enormous amounts of energy and produce a vast amount of greenhouse gases, leading to adverse effects on the environment. The carbon footprint of the digital industry is becoming a significant concern.

Moreover, the environmental impact of data centers extends beyond energy consumption and greenhouse gas emissions. These centers generate significant amounts of waste, including electronic equipment, batteries, and other hazardous materials that are harmful to the environment and human health. Thus, as we continue to rely more on digital technologies, it is crucial to understand their

environmental impact. We need to take necessary measures to address the environmental challenges that arise from data centers' operations, including energy consumption, greenhouse gas emissions, and waste generation, to ensure a sustainable future.

.

II. DEFINITION OF DATA CENTERS

Data centers, also known as datacenters, are large buildings similar to warehouses that house networked computers used for storing, processing, and distributing data. These facilities play a crucial role in supporting everything that happens online. Data centers are essential for the functioning of the internet, as they host servers and digital applications. Their significance in today's digital economies cannot be overstated, as they are vital for government policies, business operations, and individual activities. The intricate design of data centers involves a complex network of computers and storage devices that ensure the smooth delivery of applications and data. These facilities consist of various components such as power systems, ventilation, UPS, cooling systems, backup generators, fire suppression, and connections to external networks. (1).

Describe in detail the materials and methods used when conducting the study. The citations you make from different sources must be given and referenced in references.

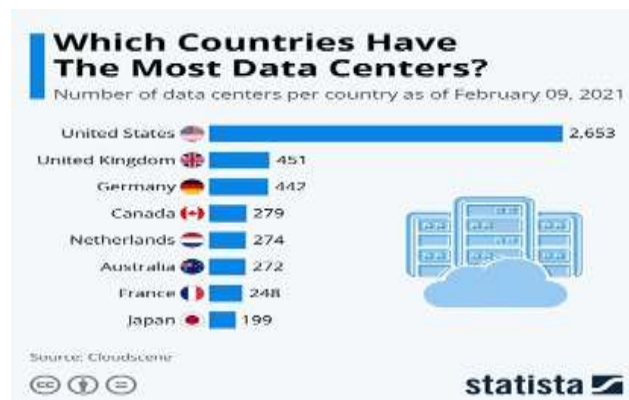

Fig.1 Data centers around the world (11)

III. TYPES OF Data Centers

IV. TYPES OF DATA CENTERS

There are different types of data centers. They are varied according to their size, type of the adopted technology, and ownership, (1) including:

Managed Data Centers :are facilities that are operated and maintained by a third-party provider, offering services such as server hosting, storage, and networking.

Enterprise Data Centers : are typically owned and operated by a single organization to support its internal IT infrastructure and data storage needs.

Colocation Data Centers : are facilities where multiple organizations can rent space for their servers and networking equipment, sharing resources and infrastructure.

Cloud-based Data Centers : provide virtualized computing resources over the internet, allowing users to access and manage their data and applications remotely.

Edge Data Centers :are smaller facilities located closer to end-users to reduce latency and improve performance for applications that require real-time data processing.

Multi-tenant Data Centers : are massive facilities that house thousands of servers and storage systems, designed to support the high demands of cloud computing and big data processing. and requirements of organizations (2).



Fig.2 Data Centers types (3)

III. Benefits of Data Centers

Data centers provide numerous advantages, including :

1. *Scalability*: Data centers are designed to be easily scalable, allowing businesses to quickly expand their storage and computing capabilities as needed.

2. *Reliability*: Data centers are equipped with redundant power supplies, cooling systems, and network connections to ensure maximum uptime and reliability for critical business operations.

3. *Security*: Data centers are equipped with state-of-the-art security measures, s1. *Scalability*: Data centers are designed to be easily scalable, allowing businesses to quickly expand their storage and computing capabilities as needed.

4. *Cost-effectiveness*: By outsourcing their data storage and management to a data center, businesses can save on the costs of building and maintaining their own infrastructure, as well as benefit from economies of scale.

5. *Compliance*: Data centers are often certified to meet industry-specific regulatory requirements, such as HIPAA for healthcare data or PCI DSS for payment card information, helping businesses ensure compliance with data protection laws.

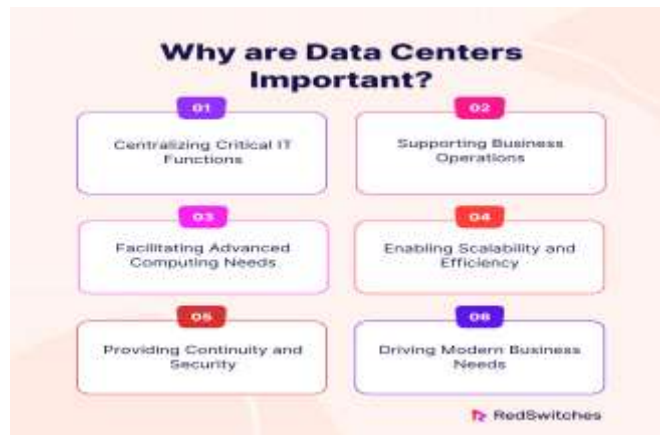

Fig.3 Benefits of Data Centers

VI. Environmental Footprint of Data Centers

Datacenters have become essential in today's digital age, providing a wide range of services such as cloud computing, storage, and data processing. With the exponential growth of data and the increasing reliance on technology, the demand for datacenters has skyrocketed. However, this surge in datacenter usage has also brought about significant hubs for environmental impacts.

One of the primary environmental concerns associated with datacenters is their massive energy consumption. These facilities require a substantial amount of electricity to power and cool the servers and networking equipment. According to studies, datacenters consume around 1-3% of the global electricity supply, and this number is expected to rise in the coming years. Moreover, The cooling systems in datacenters are particularly energy-intensive. As servers generate heat while processing and storing data, cooling mechanisms are necessary to maintain optimal operating temperatures. Traditional cooling methods, such as air conditioning, consume a significant amount of energy. The energy demand of datacenters contributes to greenhouse gas emissions, air pollution, and the depletion of natural resources. In addition to the consequences of climate change, numerous freshwater and other natural systems are gradually losing their capacity to sustain their ecological functions, all the while being compelled to cater to the ever-increasing demands of humanity (5). To address this issue, datacenters are adopting more energy-efficient cooling technologies, such as liquid cooling and free cooling, which utilize natural air or water sources to reduce energy consumption..

Another environmental concern is the substantial amount of electronic waste generated by datacenters. they responsible for generating solid waste, which includes electronic equipment that is either out of order or obsolete. Additionally, storage media, including those deliberately destroyed to maintain information confidentiality, contribute to the waste. Furthermore, life-expired or lost capacity batteries are also part of the solid waste generated by data centers (6). As technology rapidly advances, datacenters frequently upgrade their equipment to keep up with the demand for faster and more efficient processing. This leads to the disposal of outdated servers, networking devices, and other electronic components. Improper disposal of electronic waste can result in the release of hazardous materials into the environment, posing risks to human health and ecosystems. To mitigate this issue, datacenters are increasingly adopting sustainable practices, such as recycling and responsible e-waste management. Water usage is also a significant environmental impact of datacenters. Cooling systems often require large amounts of water for efficient operation. In regions where water scarcity is a concern, datacenters can strain local water resources. Furthermore, If there is a leakage of cooling agent or activation of the fire

extinguishing system, emissions and wastes in the form of liquid, gas, and solid (powder) can occur. Certain emissions are classified as pollutants. The specific emissions depend on the type of systems used, such as ethylene glycol, "waterless water/dry water" organic compounds (fluorinated ketones), halocarbons (CFCs, HFCs), and so on. When the carbon dioxide fire extinguishing system is activated, direct emission of CO₂ occurs (6) . To address this issue, datacenters are exploring water-saving technologies, such as water recycling and advanced cooling systems that minimize water consumption.

Furthermore, the construction and maintenance of datacenters can have adverse effects on land use and biodiversity. Constructing a data center involves environmental expenses, beginning with the extraction and processing of raw materials to the on-site construction activities. Each phase incurs a carbon footprint. The production processes of concrete, metals, and other construction materials are energy-intensive, and their transportation adds to greenhouse gas emissions(construction). Besides, These facilities require vast amounts of land for their infrastructure, including server rooms, power supply systems, and backup generators. The construction process can lead to deforestation, habitat destruction, and disruption of ecosystems (sol. To mitigate these impacts, datacenters are increasingly adopting sustainable building practices, such as using renewable materials and designing facilities with minimal environmental footprints. In conclusion, while datacenters play a crucial role in providing various services and meeting the growing .

Green Data Centers

Eco-friendly data centers are facilities that are designed and operated with a focus on minimizing their environmental impact. These data centers employ various strategies and technologies to reduce energy consumption, carbon emissions, and waste generation (7).

One key aspect of eco-friendly data centers is energy efficiency. These facilities utilize advanced cooling systems, such as liquid cooling or free cooling, to reduce the amount of energy required for cooling the servers. They also employ energy-efficient hardware and optimize server utilization to minimize energy waste. Additionally, eco-friendly data centers often use renewable energy sources, such as solar or wind power, to power their operations, further reducing their carbon footprint (7).

Another important aspect of eco-friendly data centers is waste management. These facilities implement recycling programs to properly dispose of electronic waste, such as old servers or networking equipment. They also prioritize the use of environmentally friendly materials in their construction and equipment, reducing the amount of waste generated during the facility's lifecycle (8).

Water conservation is also a focus for eco-friendly data centers. These facilities implement water-saving measures, such as using water-efficient cooling systems or implementing rainwater harvesting systems for non-potable water needs. By reducing water consumption, eco-friendly data centers help conserve this valuable resource (11).

Furthermore, eco-friendly data centers prioritize sustainable practices throughout their operations. They may implement green building designs, such as using natural lighting or incorporating green spaces, to reduce energy consumption and create a healthier work environment. These facilities may also participate in carbon offset programs or engage in community initiatives to promote environmental sustainability beyond their own operations (11).

Overall, eco-friendly data centers play a crucial role in reducing the environmental impact of the rapidly growing digital infrastructure. By implementing energy-efficient technologies, waste management strategies, water conservation measures, and sustainable practices, these facilities demonstrate a

commitment to environmental stewardship while still meeting the increasing demand for data storage and processing.



Fig.4 Green data centers (12)

V. CONCLUSION

The remarkable progress of data centers in recent years has been accompanied by an exponential increase in the demand placed on them. As more and more businesses and individuals rely on data centers for their computing and storage needs, the environmental pressures on these facilities have also grown significantly. One effective way to incentivize data centers to reduce their environmental impact is by implementing fees for pollutant factors. By imposing charges on carbon emissions and other pollutants, data centers would have a financial motivation to adopt cleaner and more energy-efficient technologies. Furthermore, this study emphasizes the need for additional research and investigations into the development of sustainable data centers. As the ongoing digital revolution continues to drive the growth of data centers, it is imperative to find innovative solutions that minimize their environmental footprint.

ACKNOWLEDGMENT

I would like to express my deep gratitude to all of the researchers who contributed writings the topic of data centers environmental footprint and who assisted me in carrying out this modest task.

I would also like to express my very great appreciation to the conference organizers for encouraging me to take on this project.

I am also grateful to the anonymous peer reviewers for their insightful comments.

REFERENCES

1. Priyadarshana Mishra, HOW DATA CENTERS CAN BE MADE MORE SUSTAINABLE?, Major Project Dissertation Report, Roll no: 2K21/EMBA/35,2023
2. <https://www.esds.co.in/blog/data-center-services-and-its-different-types/>
3. Data Center Services and Its different types <https://www.esds.co.in/blog/data-center-services-and-its-different-types/>, May31st, 2024
4. Introduction to Data Centers : Everything to know in 2024,<https://www.redswitches.com/blog/types-of-data-centers/>, January 24th,2024
5. Bora Ristic, Kaveh Madani, Zen Makuch, The water Footprint of Data centers
6. Andrey Semenov,Ekaterina Oganessian,Data Centers environmental Impact Assessment Features, E3S Web of Conferences 311, 04007 (2021) <https://doi.org/10.1051/e3sconf/202131104007>
7. Nazif Salihović, Belma Memić, Alem Čolaković, Elma Avdagić-Golub,Towards Green Data Centers: Energy Efficiency and Performance Evaluation, 2023 22 nd International Symposium INFOTEH-JAHORINA, DOI:[10.1109/INFOTEH57020.2023.10094184](https://doi.org/10.1109/INFOTEH57020.2023.10094184), 2023

8. Yin Zhang, Zhiyuan Wei, Mingshan Zhang, Free cooling technologies for data centers: energy saving mechanism and applications, Applied Energy Symposium & Forum: Low Carbon Cities & Urban Energy Joint Conference. 10.1016/j.egypro.2017.12.703
9. cbre.com/uptime, THE GREENER PATH Operational Strategies for a More Sustainable Data Center Securing a Safer, More Profitable Future,2021
10. Mar Hidalgo, Energy and water consumption in data centers: sustainability risks, 69/2022 02/11/2022
11. <https://stl.tech/blog/data-centers-what-why-and-how/>



Anomaly Detection Implementation with Digital Twin Approach Using Isolation Forest

Elif Cesur*, Aleyna Yemekci ²

¹ Industrial Engineering / Faculty of Engineering and Natural Sciences, Istanbul Medeniyet University, Turkey

² Industrial Engineering / Faculty of Engineering and Natural Sciences, Istanbul Medeniyet University, Turkey

* elif.karakaya@medeniyet.edu.tr

Abstract – The concept of digital twins, introduced into our lives with Industry 4.0, is becoming increasingly widespread. With digital twins, the interaction between the virtual and physical environments can be monitored in real time, allowing for iterative operations and obtaining insights from data collected by sensors. Moreover, maintenance activities in businesses have started to become more prevalent to prevent potential time and financial losses, predict and prevent failures in advance through predictive maintenance processes.

On the other hand, anomaly detection allows deviations and behaviors from the norm to be identified, enabling the prediction of potential failures and the implementation of necessary measures. This helps to prevent high maintenance costs and time losses such as machine downtimes, thereby increasing system reliability. In this study, anomaly detection was performed using data collected from three sensors installed on an elevator to contribute to the literature. While performing anomaly detection, the Isolation Forest (iForest) algorithm was selected, based on its use within the AutoML library called Pycaret. iForest is one of the unsupervised algorithms used in anomaly detection. It is theoretically based on decision trees and has a distance-based detection approach. It is used to isolate outlier values in the dataset to detect anomalies. As a result of the study, we gathered 106,421 data points, with 5,580 identified as outliers by the iForest algorithm, and examined, revealing the conditions and value ranges in which anomalies were detected. These value ranges provide an opportunity to interpret the optimum levels at which parameters should be maintained to prevent anomalies from occurring.

Keywords - Digital Twin, Anomaly Detection, Predictive Maintenance, Isolation Forest, Smart Manufacturing

I. INTRODUCTION

With Industry 4.0, the concepts of big data, artificial intelligence, blockchain, the Internet of Things, and digital twins have emerged and become widespread. With these developments, the importance of data and information has increased significantly. The importance of making data meaningful, analyzing it, and using it in decision processes is understood.

Digital twins can be used in the life cycle of product development, design, operation, maintenance, service, and production because they can monitor the interaction of the virtual environment and the physical environment in real time, allow iterative operations, and have complete information on the data [1].

Keeping pace with the continuously evolving Industry 4.0 technologies enables businesses to generate more effective results. Recent studies indicate an increasing use of digital twins for modeling objects in a manner consistent with the real world, detecting anomalies, and creating maintenance plans.

The transformation of data into meaningful insights and progress in decision and production processes based on this information contributes to a higher quality production process. Therefore, the use of digital twins, enabling real-time data collection, has gained significance in today's context.



Figure 1. Digital twin technology [2]

Anomalies are data points that stand out among other data in a dataset, deviating from the typical behavior of the data set as outlier values. These data points exhibit differences from the behavioral patterns of the data group. Anomaly detection is considered the problem of identifying patterns in outlier data that do not conform to the expected behavior of the data [3],[4].

Anomaly detection is the observation of outlier data points that deviate from the general pattern of data in data analysis. The reason for this is that anomaly detection ensures avoidance of potential adverse events. While anomaly detection used to be done manually in the past, today, machine learning algorithms are employed to achieve better results

The study involves an anomaly detection application using an elevator dataset. In the first step, the dataset was analyzed through data preprocessing steps. The second step involved examining correlation values and visualizing the data. Thirdly, anomaly detection was performed. In this stage, anomaly detection models from the AutoML library, specifically the Pycaret library, were explored, and the iForest algorithm was selected and applied.

After the application, the data identified as anomalies by the iForest algorithm was visually represented, and the values were interpreted.

II. LITERATURE REVIEW

The literature addresses maintenance costs and methods developed to reduce these costs. Predictive maintenance plays a significant role in reducing maintenance costs and downtime.

Digital twin applications are implemented to prevent, take preventive measures, and predict errors before they occur. The models created as a result of these studies are transformed into usable and interpretable information through data analyses.

Emerging anomaly detection algorithms are noteworthy for predicting potential issues in advance.

Wang and his team aimed to better understand deep learning-based anomaly detection systems. In their study, they began by explaining the anomaly detection techniques used before deep learning structures and later provided a discussion on the strategies employed by modern deep learning-based anomaly detection techniques, which utilize high technology extensively, to overcome challenges faced by previous traditional algorithms [7].

In the study conducted by Hsieh and others, an algorithm proposed to detect abnormalities in intelligent manufacturing systems using real-time data collected simultaneously from devices in manufacturing systems was examined. To identify limited and irregular abnormal data in multivariate sensor datasets obtained from the production line, an unsupervised real-time anomaly detection algorithm based on

autoencoders was applied. The results demonstrated a success rate of 90% in anomaly detection for this proposed algorithm [8].

III. MATERIALS AND METHOD

ISOLATION FOREST ALGORITHM

The Isolation Forest is one of the unsupervised algorithms used in anomaly detection. It is theoretically based on decision trees and employs distance-based detection [5]. It is utilized to isolate and identify anomalies by isolating outlier values within the dataset.

Algorithm Steps:

1. A random feature is selected.
2. Maximum and minimum values are determined for the selected feature.
3. A random value is chosen within these bounds.
4. An outlier is isolated by examining data points above and below the selected value. If a data point is below the chosen threshold, it branches left; if it is above, it branches right.

This process continues recursively until each data point is completely isolated or reaches maximum depth if defined.

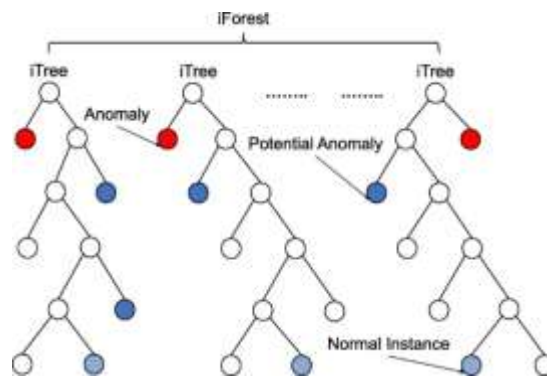

Figure 2. iForest structure

As in other anomaly detection methods, an anomaly score is calculated. During scoring, each data point is passed through all the previously trained trees. An 'anomaly score' based on the depth of the tree required to reach that point is assigned to each data point. This score is a combination of the depths obtained from each isolation tree.

If the obtained score is close to 1, it is labeled as anomalous; if it is less than 0.5, it is considered normal. An assignment of -1 or 0 is given to data points identified as anomalies, while normal data points receive a label of 1. When constructing the algorithm, parameter values are specified for the dataset to achieve optimal performance. These parameters can be adjusted to enhance the algorithm's overall effectiveness.

IV. RESULTS

An anomaly detection application has been implemented on the dataset created using the digital twin. The dataset consists of 3 columns and 112,002 rows.

Data preprocessing steps were applied to organize the dataset, and corruptions were detected. Punctuation errors and values perceived as dates were filtered and corrected to enhance the dataset's integrity.

Statistical measures, including the mean, standard deviation, minimum, maximum, and quartile values, have been determined for each column in the dataset.

	ball-bearing	humidity	vibration
count	112001.000000	112001.000000	112001.000000
mean	46.275452	74.224140	28.773674
std	19.041852	0.684711	24.517300
min	16.933000	72.399000	2.000000
25%	29.651000	73.914000	8.000000
50%	43.348000	74.212000	21.390000
75%	63.997000	74.731000	39.685000
max	93.744000	75.400000	99.995000

Figure 3. Data set statistical values

The correlation between columns of the dataset has been examined.

	ball-bearing	humidity	vibration
ball-bearing	1.000000	-0.101482	-0.105080
humidity	-0.101482	1.000000	0.153545
vibration	-0.105080	0.153545	1.000000

Figure 4. Data set correlation values

The iForest algorithm, which is an unsupervised anomaly detection algorithm, has been applied.

	ball-bearing	humidity	vibration	Anomaly	Anomaly_Score
11025	68.771004	72.873001	23.632999	0	-0.044215
108249	19.351000	73.582001	35.742001	0	-0.099915
36580	61.960999	74.940002	84.105003	1	0.004932
45444	46.558998	75.208000	8.556000	0	-0.098836
56096	43.313999	73.922997	54.463001	0	-0.078350
12646	67.820999	74.565002	8.030000	0	-0.126815
71832	36.612999	73.925003	68.737999	0	-0.082642
5236	77.114998	72.607002	21.691000	0	-0.058317
109381	20.677000	74.014000	22.033001	0	-0.117088

Figure 5. Output of the iForest algorithm

The t-SNE (t-distributed Stochastic Neighbor Embedding) plot has been utilized to visualize the high-dimensional dataset obtained as a result of applying the trained model.

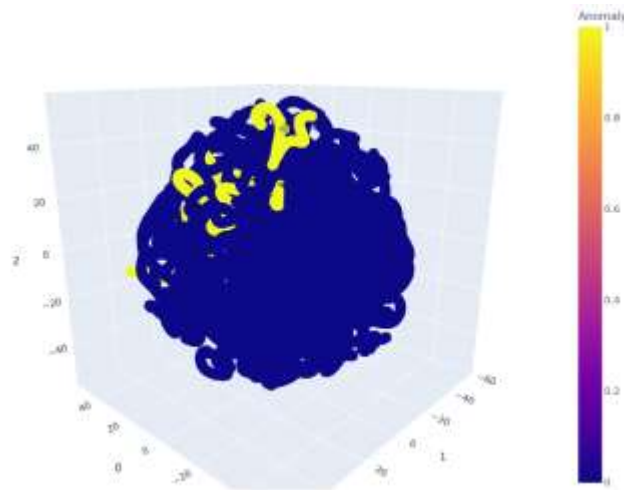

Figure 6. t-SNE Plot

The values identified as anomalies through the iForest algorithm have been visualized.

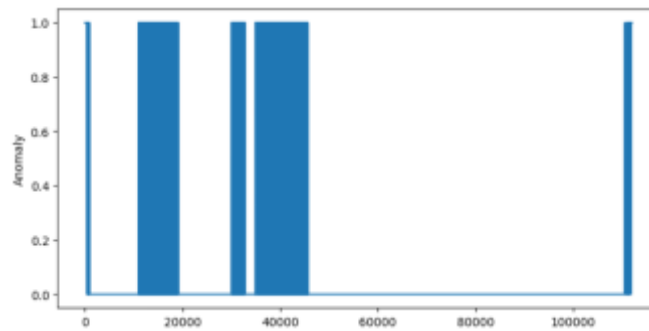

Figure 7. Distribution of values identified as anomalies by the iForest algorithm

Correlation analysis has been conducted to observe the relationship between the results and the columns. In the study, an anomaly detection application was implemented on the digital twin dataset. The 'elevator' dataset, obtained by creating a digital twin through, was utilized for this purpose. Anomaly detection was performed using the Pycaret libraries, specifically employing the unsupervised anomaly detection algorithm isolation forest. In the initial stage, noise in the dataset was eliminated. Subsequently, data preprocessing steps were taken to obtain information about the dataset as a whole. The data was visualized, and upon examining correlation ratios, it was observed that the internal correlations within the dataset were relatively low. This indicates that the features of the dataset have minimal influence on each other.

As a result of the algorithm, 106,421 data points were identified as normal, while 5,580 data points were classified as anomalies. A subsequent correlation analysis was performed with the anomaly results. According to the correlation analysis of the iForest algorithm, anomalies showed a positive relationship with the 'vibration' column at a rate of 43%.

Upon examining the values identified as anomalies by the algorithms, it became possible to predict when anomalies would occur based on which values the features approached. Looking at the relationship of the columns with the data identified as anomalies in Figure 9, it was observed that the 'humidity' column had no significant impact on anomalies. On the other hand, the variability between the 'ball-bearing' and 'vibration' columns was found to be influential on anomalies.

It is anticipated that optimizing parameter values will enhance the efficiency of the applied model, leading to a significant reduction in costs based on predictive maintenance activities.

	ball-bearing	humidity	vibration	iforest anomaly
ball-bearing	1	-	-	-
humidity	0,101482074	1	-	-
vibration	0,105079682	0,153545	1	-
iforest anomaly	0,200021017	0,109895	0,434265	1

Figure 8. Correlation analysis for anomaly values

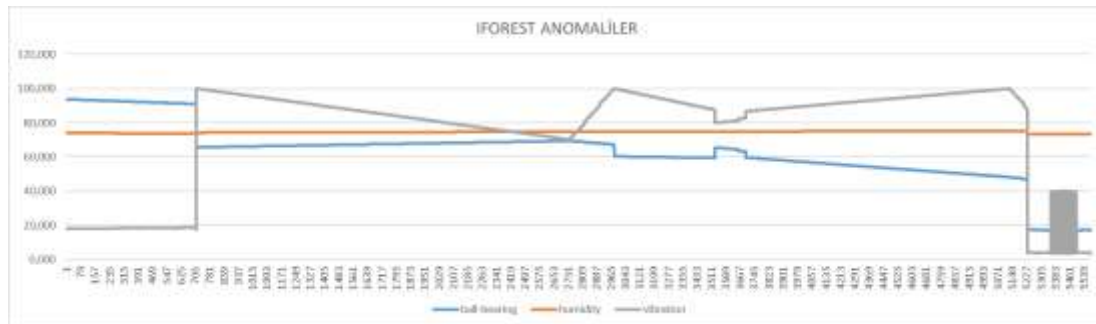

Figure 9. Interaction of anomalies with column value

V. CONCLUSION

The significance of technologies evolving with Industry 4.0 is rapidly increasing in today's world. One of these technologies is the digital twin, which enables real-time monitoring of interactions between virtual and physical environments, facilitates easier observation of changes, and allows for more effective analysis of errors. It is observed that with digital twin technology, it is possible to analyze potential fault situations of any object or system that can be simultaneously tracked in real-time, detect anomalies in advance, and thereby prevent or mitigate losses.

In this study, anomaly detection was implemented for the 'elevator' dataset, generated from sensor data installed in the elevator. The goal was to contribute to the literature by introducing an anomaly detection application, enabling proactive intervention to anticipate potential malfunction scenarios in elevators and thereby preventing both high maintenance costs and time losses.

Analyzing potential failure scenarios and proactively detecting anomalies for any object or system that can be simultaneously tracked with digital twin technology has become increasingly crucial. This capability allows for preventing or minimizing losses effectively.

This study contributes to the literature by applying the iForest algorithm, one of the anomaly detection methods, to detect anomalies.

REFERENCES

- [1] S. M. Metev and V. P. Veiko, *Laser Assisted Microtechnology*, 2nd ed., R. M. Osgood, Jr., Ed. Berlin, Germany: Springer-Verlag, 1998.
- [2] J. Breckling, Ed., *The Analysis of Directional Time Series: Applications to Wind Speed and Direction*, ser. Lecture Notes in Statistics. Berlin, Germany: Springer, 1989, vol. 61.
- [3] S. Zhang, C. Zhu, J. K. O. Sin, and P. K. T. Mok, "A novel ultrathin elevated channel low-temperature poly-Si TFT," *IEEE Electron Device Lett.*, vol. 20, pp. 569–571, Nov. 1999.
- [4] M. Wegmuller, J. P. von der Weid, P. Oberson, and N. Gisin, "High-resolution fiber distributed measurements with coherent OFDR," in *Proc. ECOC'00*, 2000, paper 11.3.4, p. 109.
- [5] R. E. Sorace, V. S. Reinhardt, and S. A. Vaughn, "High-speed digital-to-RF converter," U.S. Patent 5 668 842, Sept. 16, 1997.
- [6] (2002) The IEEE website. [Online]. Available: <http://www.ieee.org/>

- [7] M. Shell. (2002) IEEEtran homepage on CTAN. [Online]. Available: <http://www.ctan.org/tex-archive/macros/latex/contrib/supported/IEEEtran/>
- [8] *FLEXChip Signal Processor (MC68175/D)*, Motorola, 1996.
- [9] "PDCA12-70 data sheet," Opto Speed SA, Mezzovico, Switzerland.
- [10] A. Karnik, "Performance of TCP congestion control with rate feedback: TCP/ABR and rate adaptive TCP/IP," M. Eng. thesis, Indian Institute of Science, Bangalore, India, Jan. 1999.
- [11] J. Padhye, V. Firoiu, and D. Towsley, "A stochastic model of TCP Reno congestion avoidance and control," Univ. of Massachusetts, Amherst, MA, CMPSCI Tech. Rep. 99-02, 1999.
- [12] *Wireless LAN Medium Access Control (MAC) and Physical Layer (PHY) Specification*, IEEE Std. 802.11, 1997.